

## Lenovo ThinkSystem SR650 V4 Server Product Guide

The Lenovo ThinkSystem SR650 V4 is an ideal 2-socket 2U rack server for customers that need industry-leading reliability, management, and security, as well as maximizing performance and flexibility for future growth. The SR650 V4 is based on two Intel Xeon 6700-series or Xeon 6500-series processors, with Performance-cores (P-cores), formerly codenamed "Granite Rapids-SP".

The SR650 V4 is designed to handle a wide range of workloads, such as databases, virtualization and cloud computing, virtual desktop infrastructure (VDI), infrastructure security, systems management, enterprise applications, collaboration/email, streaming media, web, and HPC.



Figure 1. Lenovo ThinkSystem SR650 V4 with optional security bezel

### Did you know?

The SR650 V4 server supports a variety of cooling options including the new Lenovo Compute Complex Neptune Core module which uses open-loop liquid cooling to remove the heat from processors, memory, and voltage regulators. This Neptune Core module can remove more than 80% of heat from the server using liquid cooling, resulting in up to 35.9% power savings at the data center level. See the [Lenovo Compute Complex Neptune Core Module](#) section for details.

For additional GPU support in a 2U rack form factor, with support for 4 double-wide GPUs with NVLink, consider the [ThinkSystem SR650a V4 server](#).

## Key features

Combining performance and flexibility, the SR650 V4 server is a great choice for enterprises of all sizes. The server offers a broad selection of drive and slot configurations and offers numerous high performance features. Outstanding reliability, availability, and serviceability (RAS) and high-efficiency design can improve your business environment and can help save operational costs.

### Scalability and performance

The ThinkSystem SR650 V4 offers numerous features to boost performance, improve scalability and reduce costs:

- Supports one or two Intel Xeon 6700-series or 6500-series processors with Performance-cores (P-cores)
  - Up to 86 cores and 172 threads
  - Core speeds of up to 4 GHz
  - TDP ratings of up to 350 W
- Support for DDR5 memory DIMMs to maximize the performance of the memory subsystem:
  - Up to 32 DDR5 memory DIMMs, 16 DIMMs per processor
  - 8 memory channels per processor (2 DIMMs per channel)
  - Supports 1 DIMM per channel operating at 6400 MHz
  - Supports 2 DIMMs per channel operating at 5200 MHz
  - Using 256GB 3D RDIMMs, the server supports up to 8TB of system memory
- Support for MRDIMMs for increased memory bandwidth with memory bus speeds of up to 8000 MHz.
- Support for Compute Express Link (CXL) memory DIMMs in an E3.S 2T form factor, up to 12x CXL DIMMs with two processors. With CXL 2.0 for next-generation workloads, you can reduce compute latency in the data center and lower TCO. CXL is a protocol that runs across the standard PCIe physical layer and can support both standard PCIe devices as well as CXL devices on the same link.
- Supports up to 10x single-width GPUs or 2x double-wide GPUs, for substantial processing power in a 2U system. For support for 4x double-wide GPUs, consider the [ThinkSystem SR650a V4 server](#).
- Supports up to 40x 2.5-inch drive bays, by using combinations of front-accessible (up to 24 hot-swap bays), mid bays (8 simple-swap bays) and rear-accessible (8 hot-swap bays).
- Supports 36x NVMe drives without oversubscription of PCIe lanes (1:1 connectivity). The use of NVMe drives maximizes drive I/O performance, in terms of throughput and latency.
- Supports up to 16x 3.5-inch drive bays for lower-cost high-capacity HDD storage. 2.5-inch and 3.5-inch drive bays can be mixed if desired.
- Support for up to 32x E3.S 1T NVMe drives, a new form factor drive for high-density and high-performance storage.
- Supports high-speed RAID controllers providing 12 Gb SAS connectivity to the drive backplanes. A variety of PCIe 3.0 and PCIe 4.0 RAID adapters are available.
- Supports M.2 drives for convenient operating system boot functions or data storage. M.2 drives can be internally mounted or can be mounted at the front or rear of the server as hot-swap drives. Optional RAID-0 or RAID-1.
- Up to 10x PCIe slots (rear accessible), plus two slots dedicated to OCP 3.0 adapters. 2.5-inch drive configurations also support an additional internal bay for a cabled RAID adapter or HBA.
- The server has up to two dedicated industry-standard OCP 3.0 slots supporting a variety of Ethernet network adapters. A simple-swap mechanism with a thumbscrew and pull-tab enables tool-less installation and removal of the adapter. The adapter supports shared BMC network sideband connectivity to enable out-of-band systems management.
- The server offers PCI Express 5.0 I/O expansion capabilities that doubles the theoretical maximum bandwidth of PCIe 4.0 (32GT/s in each direction for PCIe Gen 5, compared to 16 GT/s with PCIe Gen 4 and 8 GT/s with PCIe Gen 3). A PCIe 5.0 x16 slot provides 128 GB/s bandwidth, enough to support a dual-port 200GbE network connection or a single-port 400GbE connection.

### Availability and serviceability

The SR650 V4 provides many features to simplify serviceability and increase system uptime:

- Designed to run 24 hours a day, 7 days a week
- The server offers Single Device Data Correction (SDDC, also known as Chipkill), Adaptive Double-Device Data Correction (ADDDC, also known as Redundant Bit Steering or RBS), and memory mirroring for redundancy in the event of a non-correctable memory failure.
- The server offers hot-swap drives, supporting RAID redundancy for data protection and greater system uptime.
- Available M.2 boot adapters support RAID-1 (using onboard hardware RAID or using Intel VROC) which can enable two M.2 drives to be configured as a redundant pair.
- The server has up to two hot-swap redundant power supplies and up to six hot-swap redundant fans to provide availability for business-critical applications.
- The light path diagnostics feature uses LEDs to lead the technician to failed (or failing) components, which simplifies servicing, speeds up problem resolution, and helps improve system availability.
- Solid-state drives (SSDs) offer more reliability and performance than traditional mechanical HDDs for greater uptime.
- Proactive Platform Alerts (including PFA and SMART alerts): Processors, voltage regulators, memory, internal storage (SAS/SATA HDDs and SSDs, NVMe SSDs, M.2 storage, flash storage adapters), fans, power supplies, RAID controllers, server ambient and subcomponent temperatures. Alerts can be surfaced through the XClarity Controller to managers such as Lenovo XClarity Administrator, VMware vCenter, and Microsoft System Center. These proactive alerts let you take appropriate actions in advance of possible failure, thereby increasing server uptime and application availability.
- The built-in XClarity Controller continuously monitors system parameters, triggers alerts, and performs recovery actions in case of failures to minimize downtime.
- Built-in diagnostics in UEFI, using Lenovo XClarity Provisioning Manager, speed up troubleshooting tasks to reduce service time.
- Lenovo XClarity Provisioning Manager supports diagnostics and can save service data to a USB key drive or remote CIFS share folder for troubleshooting and reduce service time.
- Auto restart in the event of a momentary loss of AC power (based on power policy setting in the XClarity Controller service processor)
- Offers a diagnostics port on the front of the server to allow you to attach an external diagnostics handset for enhanced systems management capabilities.
- Support for the XClarity Administrator Mobile app running on a supported smartphone or tablet and connected to the server through the service-enabled USB port, enables additional local systems management functions.
- Three-year or one-year customer-replaceable unit and onsite limited warranty (varies by geography), 9 x 5 next business day. Optional service upgrades are available.

### **Manageability and security**

Systems management features simplify local and remote management of the SR650 V4:

- The server includes XClarity Controller 3 (XCC3) to monitor server availability. Optional upgrade to XCC3 Premier to provide remote control (keyboard video mouse) functions, support for the mounting of remote media files (ISO and IMG image files), boot capture and power capping. XCC3 Premier also offers additional features such as Neighbor Groups, System Guard, a CNSA-compliant security mode, a FIPS 140-3-compliant mode, and enhanced NIST 800-193 support.
- Dedicated Ethernet port at the rear of the server for remote management (BMC management). Optional support for a second dedicated BMC management port, installed in the OCP adapter bay.
- Lenovo XClarity Administrator offers comprehensive hardware management tools that help to increase uptime, reduce costs and improve productivity through advanced server management capabilities.
- UEFI-based Lenovo XClarity Provisioning Manager, accessible from F1 during boot, provides system inventory information, graphical UEFI Setup, platform update function, RAID Setup wizard, operating system installation function, and diagnostic functions.
- Support for Lenovo XClarity Energy Manager which captures real-time power and temperature data from

the server and provides automated controls to lower energy costs.

- An integrated industry-standard Unified Extensible Firmware Interface (UEFI) enables improved setup, configuration, and updates, and simplifies error handling.
- Support for industry standard management protocols, IPMI 2.0, SNMP 3.0, Redfish REST API, serial console via IPMI
- Enhanced security for storage connectivity with Fibre Channel adapters such as the Emulex SecureHBA, which provides autonomous in-flight encryption with integrated post-quantum cryptography (PQC) algorithms and CNSA 1.0 and 2.0 compliance.
- An integrated hardware Trusted Platform Module (TPM) supporting TPM 2.0 enables advanced cryptographic functionality, such as digital signatures and remote attestation.
- Administrator and power-on passwords help protect from unauthorized access to the server.
- Supports Secure Boot to ensure only a digitally signed operating system can be used. Supported with HDDs and SSDs, as well as M.2 drives.
- Industry-standard Advanced Encryption Standard (AES) NI support for faster, stronger encryption.
- Intel Execute Disable Bit functionality can prevent certain classes of malicious buffer overflow attacks when combined with a supported operating system.
- Intel Trusted Execution Technology provides enhanced security through hardware-based resistance to malicious software attacks, allowing an application to run in its own isolated space, protected from all other software running on a system.
- Additional physical security features are an available chassis intrusion switch and available lockable front bezel.

### **Energy efficiency**

The SR650 V4 offers the following energy-efficiency features to save energy, reduce operational costs, and increase energy availability:

- The server supports advanced Lenovo Neptune Core direct-water cooling (DWC) capabilities, where heat from key components is removed from the rack and the data center using an open loop and coolant distribution units, resulting in lower energy costs:
  - Processor Neptune Core Module uses liquid cooling to remove heat from the processors
  - Compute Complex Neptune Core Module uses liquid cooling to remove heat from the processors, memory and voltage regulators
- Energy-efficient system board components help lower operational costs.
- High-efficiency power supplies with 80 PLUS Titanium certifications
- Solid-state drives (SSDs) consume as much as 80% less power than traditional spinning 2.5-inch HDDs.
- Support for Lenovo XClarity Energy Manager provides advanced data center power notification, analysis, and policy-based management to help achieve lower heat output and reduced cooling needs.
- The server uses hexagonal ventilation holes, which can be grouped more densely than round holes, providing more efficient airflow through the system and thus keeping your system cooler.

## Comparing the SR650 V4 to the SR650 V3

The ThinkSystem SR650 V4 improves on the previous generation SR650 V3, as summarized in the following table.

Table 1. Comparing the SR650 V4 to the previous generation SR650 V3

Feature	SR650 V3	SR650 V4	Benefits
Processor	<ul style="list-style-type: none"> <li>• 2x 4th Gen Intel Xeon Scalable Processors</li> <li>• Up to 60 cores</li> <li>• TDP up to 350W</li> <li>• 80x PCIe 5.0 lanes per processor</li> </ul>	<ul style="list-style-type: none"> <li>• 2x Intel Xeon 6700 or 6500-series processors with Performance cores (P-cores)</li> <li>• up to 86 cores and 172 threads</li> <li>• TDP up to 350W</li> <li>• 88x PCIe 5.0 lanes per processor</li> </ul>	<ul style="list-style-type: none"> <li>• Significant increase in cores per processor</li> <li>• Increased performance</li> <li>• Consolidation of more apps on same number of servers, reducing costs</li> <li>• Increased number of lanes means more higher performance networking and NVMe storage</li> </ul>
Memory	<ul style="list-style-type: none"> <li>• DDR5 memory operating up to 4800 MHz</li> <li>• 8 channels per CPU</li> <li>• 32 DIMMs (16 per processor), 2 DIMMs per channel</li> <li>• Supports RDIMMs, 3DS RDIMMs and 9x4 RDIMMs</li> <li>• Up to 8TB of system memory</li> </ul>	<ul style="list-style-type: none"> <li>• DDR5 memory operating up to 6400 MHz</li> <li>• 8 channels per CPU</li> <li>• 32 DIMMs (16 per processor), 2 DIMMs per channel</li> <li>• Supports RDIMMs, 3DS RDIMMs, and MRDIMMs</li> <li>• Supports CXL 2.0 memory in E3.S 2T form factor, up to 12x DIMMs with two processors</li> <li>• Up to 8TB of system memory</li> </ul>	<ul style="list-style-type: none"> <li>• Support for new memory technologies</li> <li>• 1.7x increased memory bandwidth</li> <li>• 2.3x increased memory bandwidth with MRDIMM</li> <li>• Support for CXL memory enables additional memory support using E3.S drive bays</li> </ul>
Internal storage	<ul style="list-style-type: none"> <li>• Up to 20x 3.5", 40x 2.5" drive bays</li> <li>• Front: up to 12x3.5" / 24x2.5", hot-swap</li> <li>• Mid (internal): up to 4x3.5" / 8x2.5", hot-swap</li> <li>• Rear: up to 4x3.5" / 8x2.5", 2x7mm boot drive, hot-swap</li> <li>• 2x Internal M.2 with optional RAID 1</li> <li>• 2x rear 7mm hot swap SAS/SATA/NVMe (RAID support via VROC)</li> <li>• PCIe 4.0 and PCIe 5.0 NVMe drive support</li> <li>• 20x Onboard NVMe ports</li> <li>• NVMe Retimer adapters for 32x NVMe</li> </ul>	<ul style="list-style-type: none"> <li>• Up to 16x 3.5", 40x 2.5" drive bays, 32x E3.S</li> <li>• Front: up to 12x3.5" / 24x2.5"/ 32x E3.S, hot-swap</li> <li>• Mid (internal): 8x2.5", simple swap</li> <li>• Rear: up to 4x3.5" / 8x2.5", hot-swap</li> <li>• 2x Internal M.2 with optional RAID 1</li> <li>• 2x front or rear hot-swap M.2 with RAID 1</li> <li>• PCIe 5.0 NVMe drive support</li> <li>• 36x Onboard NVMe ports</li> </ul>	<ul style="list-style-type: none"> <li>• Flexible storage offerings</li> <li>• Up to 32x NVMe drives for high-performance storage</li> <li>• Support E3.S NVMe drives up to 32</li> <li>• M.2 for effective boot drive support</li> <li>• Support rear or front hot swap M.2 drives for increased uptime</li> <li>• Additional NVMe ports means no need for Retimer adapters, freeing up slots for other adapters</li> </ul>

Feature	SR650 V3	SR650 V4	Benefits
RAID	<ul style="list-style-type: none"> <li>• 8-, 16- and 32-port RAID adapters with up to 8GB flash</li> <li>• Support for Lenovo and Broadcom adapters</li> <li>• Support for PCIe or Internal cabled (CFF) form factor adapters</li> <li>• Support for NVMe drives connected to 940 RAID adapters (Tri-Mode)</li> <li>• Storage HBAs available</li> <li>• PCIe 3.0 and PCIe 4.0 adapter choices with support for Gen 5 adapters when available</li> </ul>	<ul style="list-style-type: none"> <li>• 8-, 16- and 32-port RAID adapters with up to 8GB flash</li> <li>• Support for Lenovo and Broadcom adapters</li> <li>• Support for PCIe or Internal cabled (CFF) form factor adapters</li> <li>• Support for NVMe drives connected to 940 RAID adapters (Tri-Mode)</li> <li>• Storage HBAs available</li> <li>• PCIe 3.0 and PCIe 4.0 adapter choices with support for Gen 5 adapters when available</li> </ul>	<ul style="list-style-type: none"> <li>• Consistent RAID/HBA support</li> <li>• Flexible config solution</li> <li>• PCIe Gen 5 allows for greater storage performance</li> </ul>
Networking	<ul style="list-style-type: none"> <li>• 1x OCP 3.0 slot with PCIe Gen 5 x16 interface</li> <li>• OCP slot can be rear or front-accessible</li> <li>• Additional PCIe adapters supported</li> <li>• 1GbE dedicated Management port</li> </ul>	<ul style="list-style-type: none"> <li>• 2x OCP 3.0 rear-accessible slots with PCIe Gen 5 interface</li> <li>• Additional PCIe adapters supported</li> <li>• 1GbE dedicated Management port</li> </ul>	<ul style="list-style-type: none"> <li>• 2x OCP slots for increased networking ports</li> </ul>
PCIe	<ul style="list-style-type: none"> <li>• Supports PCIe 5.0</li> <li>• Up to 10x rear PCIe slots (6x full height, 4x low-profile) or 8x rear PCIe slots (all full-height slots)</li> <li>• Up to 9x slots can be PCIe 5.0</li> <li>• Optional 2x additional front PCIe slots</li> <li>• Supports a RAID/HBA in CFF form factor (does not occupy a PCIe slot)</li> </ul>	<ul style="list-style-type: none"> <li>• Supports PCIe 5.0</li> <li>• Up to 10x rear PCIe slots (6x full height, 4x low-profile)</li> <li>• All slots are PCIe 5.0</li> <li>• Riser cards are modular for easy upgrades</li> <li>• Supports a RAID/HBA in CFF form factor (does not occupy a PCIe slot)</li> </ul>	<ul style="list-style-type: none"> <li>• PCIe Gen 5 allows for greater I/O performance</li> <li>• Flexible PCIe offerings</li> <li>• More PCIe connections for greater PCIe/NVMe support</li> <li>• Modular riser card design minimizes initial investment if fewer slots are needed</li> </ul>
GPU support	<ul style="list-style-type: none"> <li>• Supports up to 8x single-wide GPUs</li> <li>• Supports up to 3x double-wide GPUs</li> </ul>	<ul style="list-style-type: none"> <li>• Supports up to 10x single-wide GPUs</li> <li>• Supports up to 2x double-wide GPUs</li> </ul>	<ul style="list-style-type: none"> <li>• High performance GPU support</li> </ul>

Feature	SR650 V3	SR650 V4	Benefits
Management and security	<ul style="list-style-type: none"> <li>• Integrated XClarity Controller 2</li> <li>• Support for full XClarity toolset including XClarity Administrator</li> <li>• Platform Firmware Resiliency (PFR) hardware Root of Trust (RoT)</li> <li>• Tamper Switch security solution (intrusion switch)</li> <li>• Support for 2nd remote management port</li> </ul>	<ul style="list-style-type: none"> <li>• Integrated XClarity Controller 3</li> <li>• Support for full XClarity toolset including XClarity Administrator</li> <li>• Platform Firmware Resiliency (PFR) hardware Root of Trust (RoT)</li> <li>• Tamper Switch security solution (intrusion switch)</li> <li>• Support for 2nd remote management port</li> <li>• Support for 4-in-1 daisy-chain remote management connectivity</li> <li>• For Fibre Channel storage connectivity, available in-flight encryption adapters such as Emulex SecureHBAs</li> </ul>	<ul style="list-style-type: none"> <li>• New XCC3 offers improved management capabilities including OpenBMC support</li> <li>• Same system management tool with previous generation</li> <li>• Silicon-level security solution</li> <li>• Redundant remote management connectivity</li> <li>• Daisy-chain option to reduce the number of management switch ports required</li> <li>• Storage connectivity encryption ensures that data remains secure</li> </ul>
Power	<ul style="list-style-type: none"> <li>• Choice of 750W, 1100W, 1800W, 2400W, 2600W AC Hot Plug PSUs</li> <li>• Available in Titanium and Platinum efficiency levels</li> <li>• 1100W -48VDC Platinum general support</li> <li>• 240V HVDC support for PRC customers</li> <li>• Active-Standby mode</li> </ul>	<ul style="list-style-type: none"> <li>• Choice of 800W, 1300W, 2000W, 2700W, 3200W AC Hot Plug PSUs</li> <li>• Available in Titanium and Platinum efficiency levels</li> <li>• 1300W -48VDC general support</li> <li>• 1300W HVAC/HVDC general support</li> <li>• 240V HVDC support for PRC customers</li> <li>• Active-Standby mode</li> </ul>	<ul style="list-style-type: none"> <li>• Higher capacity power supplies to support high-powered components</li> <li>• Support Industrial CRPS form factor PSUs</li> <li>• Support for Telco customers with -48V requirements</li> <li>• Support for customers with HVDC/HVAC power requirements</li> </ul>

## Components and connectors

The following figure shows the front of the SR650 V4.

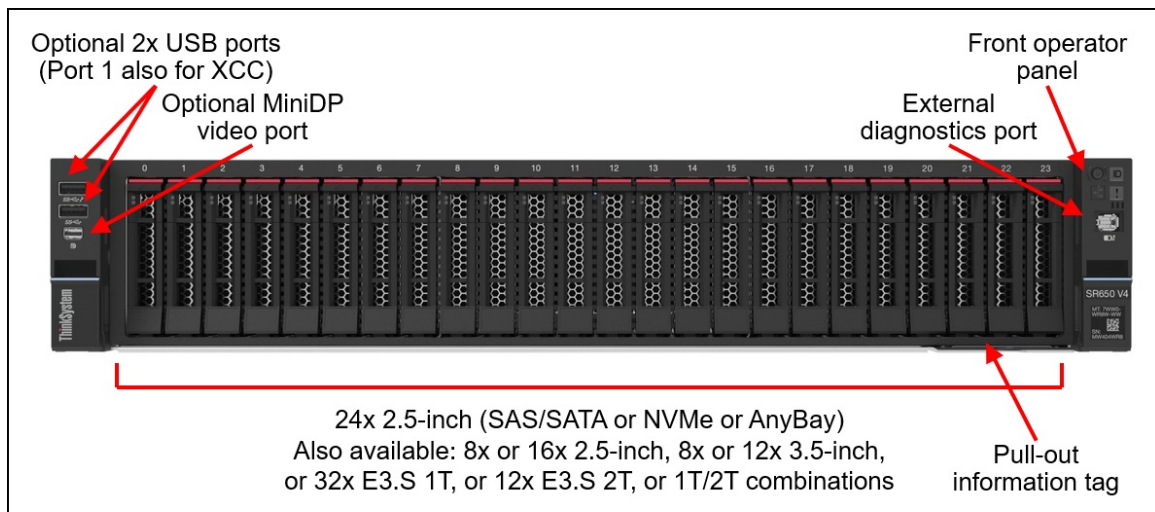

Figure 2. Front view of the ThinkSystem SR650 V4 with 2.5-inch drive bays

For details on the front ports, including the optional front VGA port and optional external diagnostic port, see the [Local management](#) section.

The following figure shows the front configurations of the SR650 V4. The server supports either 2.5-inch hot-swap drives (8, 16 or 24 drive bays) or 3.5-inch hot-swap drives (8 or 12 bays) at the front. The server also supports up to 32 E3.S 1T hot-swap drive bays or up to 12 E3.S 2T bays for CXL memory.

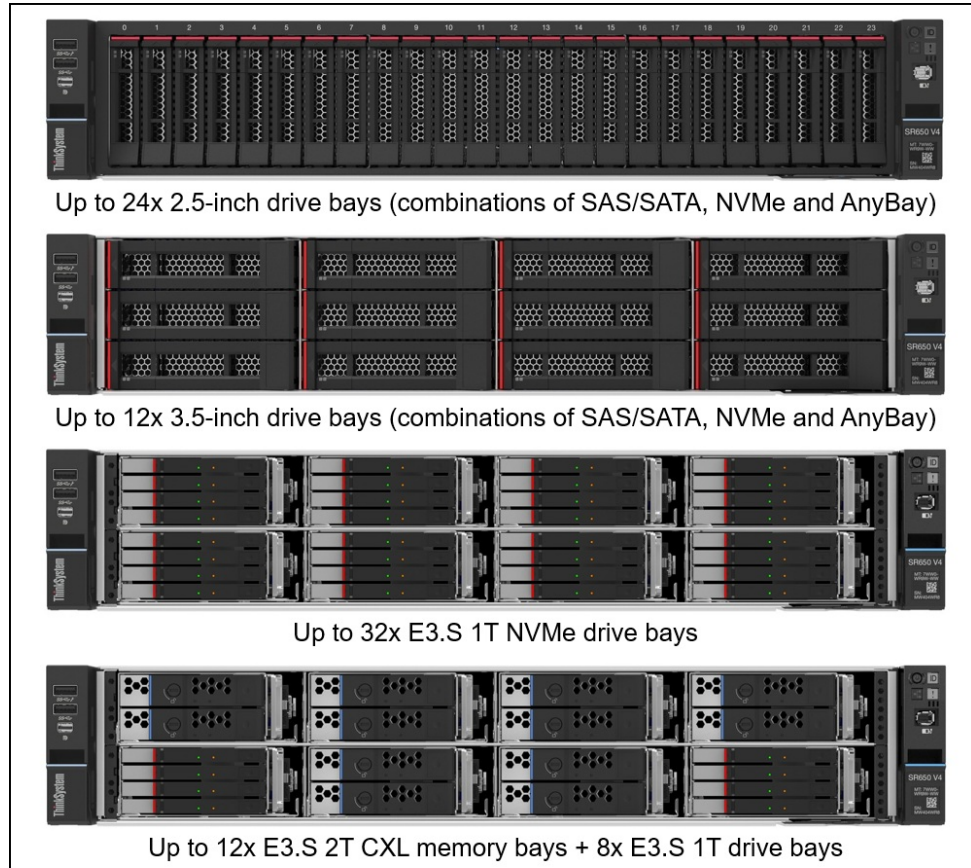

Figure 3. Front view configurations of the ThinkSystem SR650 V4

The following figure shows the components visible from the rear of the server. The figure shows one configuration, with ten PCIe slots, however there are additional rear configurations which include 3.5-inch drive bays or 2.5-inch drive bays, and rear-accessible hot-swap M.2 drive bays.

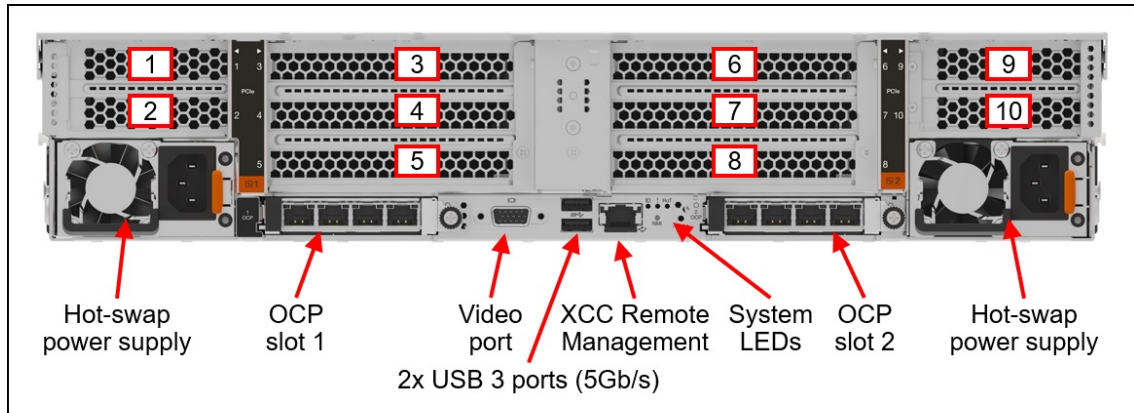

Figure 4. Rear view of the ThinkSystem SR650 V4 (configuration with ten PCIe slots)

The following figure shows the rear of the server when configured with open-loop cooling, either using the Lenovo Processor Neptune Core Module or the Lenovo Compute Complex Neptune Core Module. The inlet and outlet water hoses are routed through slot 8.

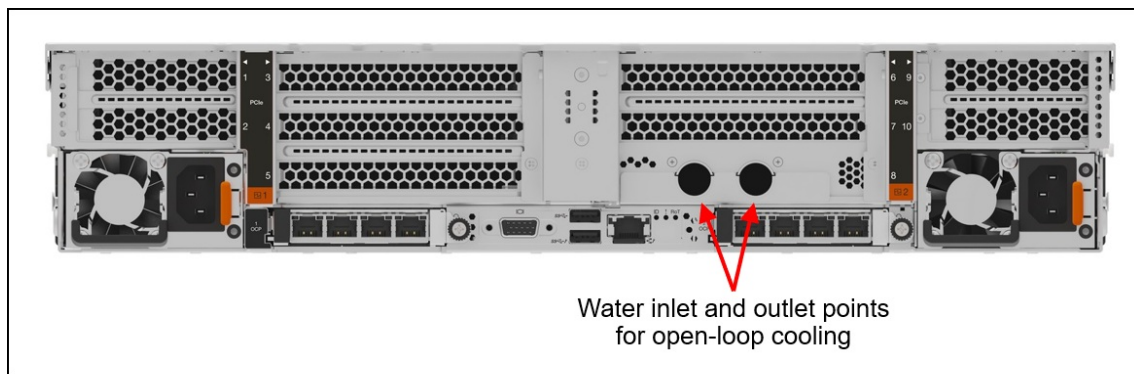

Figure 5. Rear of the SR650 V4 with open-loop water cooling

The following figure shows the locations of key components inside the server when configured with 4x 2.5-inch rear drive bays.

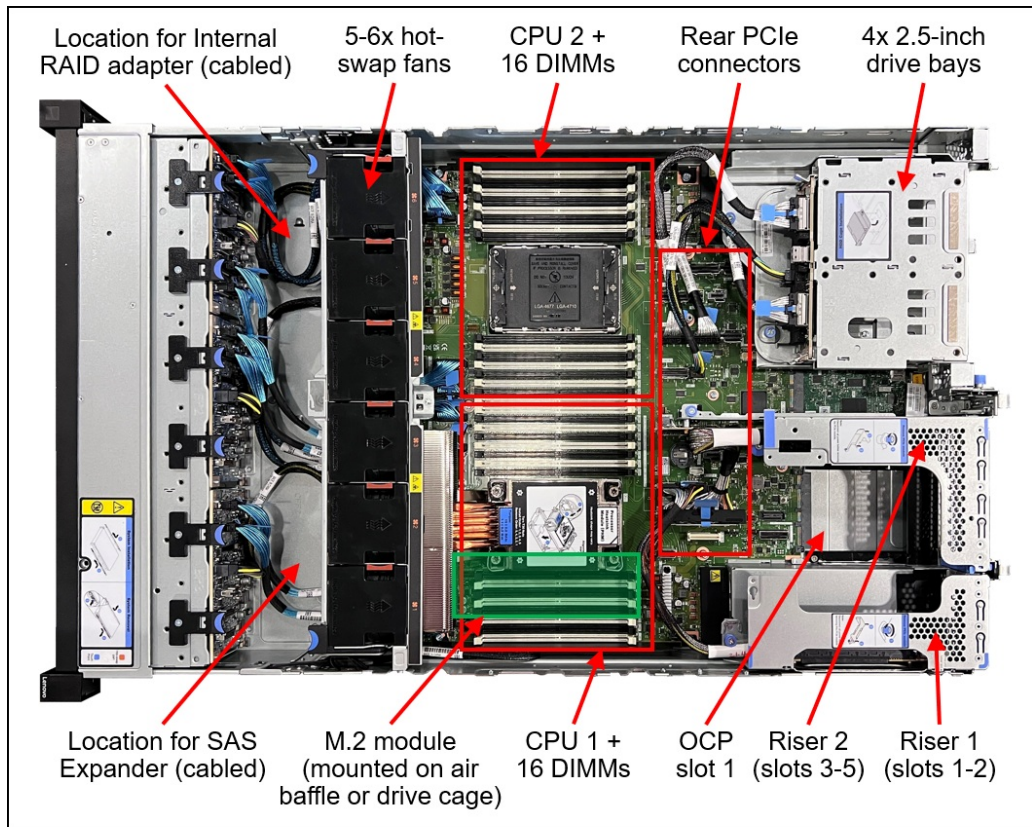

Figure 6. Internal view of the ThinkSystem SR650 V4

## System architecture

The following figure shows the architectural block diagram of the SR650 V4, showing the major components and their connections.

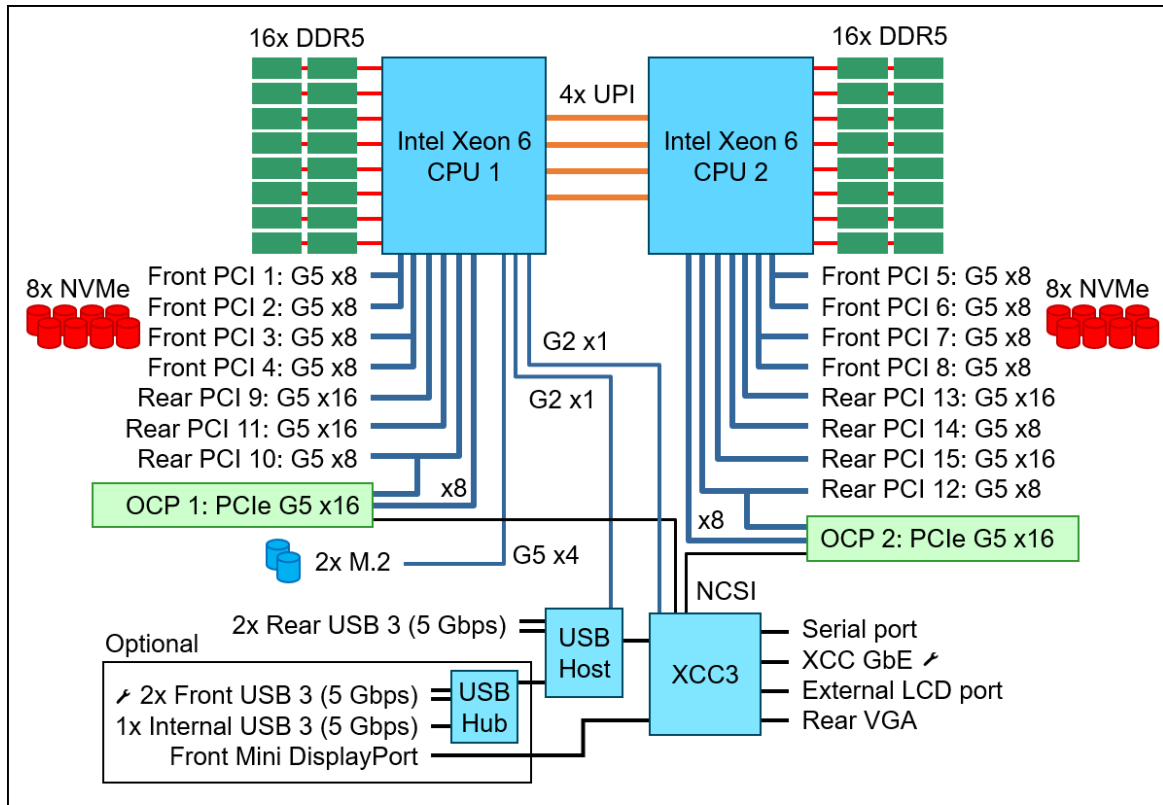

Figure 7. SR650 V4 system architectural block diagram

Most of the PCIe connections are implemented using cables, which maximizes the flexibility in how the server can be configured. For example, the block diagram below shows how a configuration with 10 rear slots is connected.

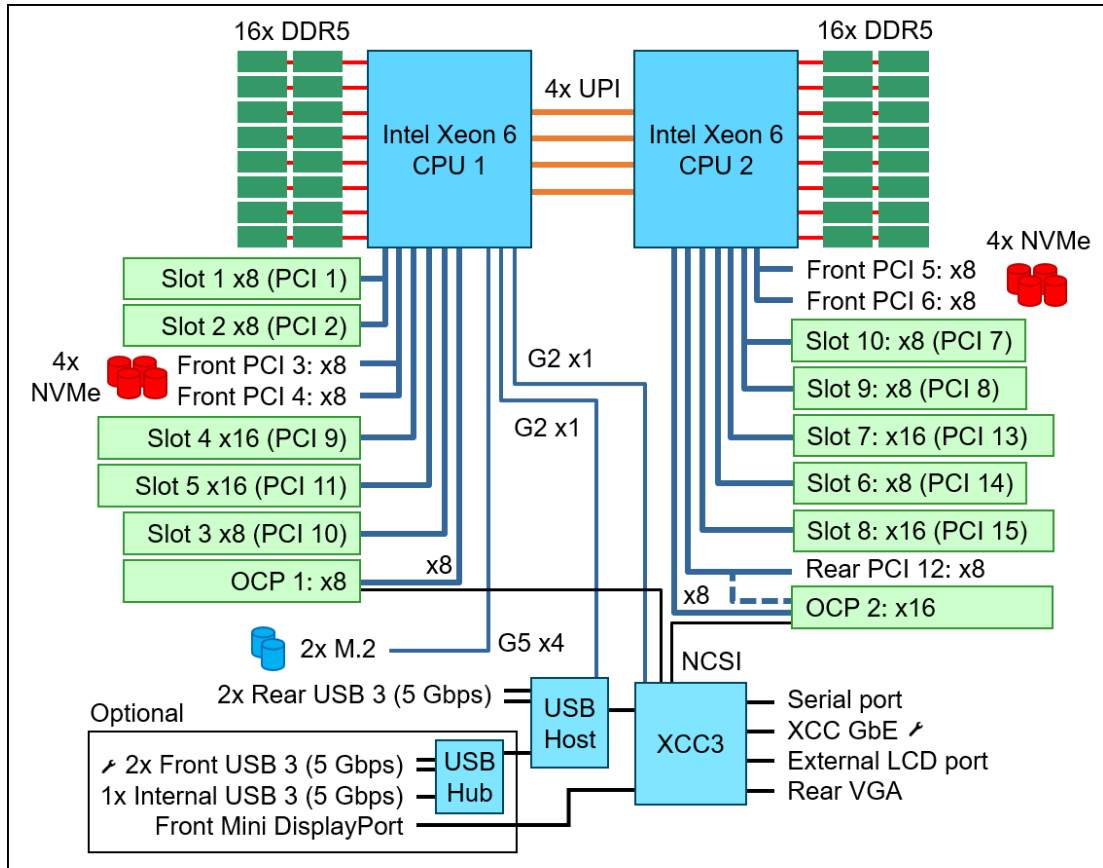

Figure 8. SR650 V4 system architectural block diagram with 10 slots

## Standard specifications

The following table lists the standard specifications.

Table 2. Standard specifications

Components	Specification
Machine types	<ul style="list-style-type: none"> <li>7DGC - 1 year warranty</li> <li>7DGD - 3 year warranty</li> <li>7DK2 - 3 year warranty - SR650 V4 with Compute Complex Neptune Core liquid cooling</li> <li>7DLN - 3 year warranty - SR650 V4 with SAP HANA</li> <li>7DGE - 1 year warranty - SR650 V4 for vSAN</li> <li>7DGF - 3 year warranty - SR650 V4 for vSAN</li> </ul>
Form factor	2U rack
Processor	One or two Intel Xeon 6700P-series or 6500P-series processors (formerly codenamed "Granite Rapids"). Supports processors up to 86 cores and 172 threads, core speeds of up to 4.0 GHz, and TDP ratings of up to 350 W.
Chipset	None. Integrated into the processor
Memory	32 DIMM slots with two processors (16 DIMM slots per processor). Each processor has 8 memory channels, with 2 DIMMs per channel (DPC). 16 DIMM slots with 2 processors when the Compute Complex Neptune Core liquid cooling is used (machine type 7DK2). Lenovo TruDDR5 RDIMMs and MRDIMMs are supported. RDIMMs operate at up to 6400 MHz at 1 DPC and up to 5200 MHz at 2 DPC. MRDIMMs are supported up to 8000 MHz at 1 DPC (no support for 2 DPC). CXL 2.0 memory is also supported, up to 12 DIMMs (6 per processor) installed in E3.S 2T drive bays.

Components	Specification
Memory maximum	Up to 8TB by using 32x 256GB 3DS RDIMMs
Memory protection	ECC, SDDC (for x4-based memory DIMMs), ADDDC (for x4-based memory DIMMs), and memory mirroring.
Disk drive bays	<p>Up to 16x 3.5-inch or 40x 2.5-inch or 32x E3.S hot-swap drive bays:</p> <ul style="list-style-type: none"> <li>• Front bays can be 3.5-inch (8 or 12 bays), or 2.5-inch (8, 16 or 24 bays), or E3.S (32 bays)</li> <li>• Middle bays are 2.5-inch (8 bays) simple-swap</li> <li>• Rear bays can be 3.5-inch (4 bays) or 2.5-inch (4 or 8 bays)</li> <li>• Combinations of SAS/SATA, NVMe, or AnyBay (supporting SAS, SATA or NVMe) are available</li> </ul> <p>M.2 support, for OS boot and drive storage support:</p> <ul style="list-style-type: none"> <li>• 2x front or rear hot-swap M.2 drive bays, or</li> <li>• Internal M.2 module supporting up to two M.2 drives</li> </ul> <p>See <a href="#">Supported drive bay combinations</a> for details. AnyBay bays support SAS, SATA or NVMe drives. NVMe bays only support NVMe drives.</p>
Maximum internal storage	<ul style="list-style-type: none"> <li>• 2.5-inch drives: <ul style="list-style-type: none"> <li>◦ 1228.8TB using 40x 30.72TB 2.5-inch SAS/SATA SSDs</li> <li>◦ 2211.84TB using 36x 61.44TB 2.5-inch NVMe SSDs</li> <li>◦ 96TB using 40x 2.4TB 2.5-inch HDDs</li> </ul> </li> <li>• E3.S drives <ul style="list-style-type: none"> <li>◦ 491.52TB using 32x 15.36TB E3.S EDSFF NVMe SSDs</li> </ul> </li> <li>• 3.5-inch drives: <ul style="list-style-type: none"> <li>◦ 384TB using 16x 24TB 3.5-inch HDDs</li> <li>◦ 245.76TB using 16x 15.36TB 3.5-inch SAS/SATA SSDs</li> <li>◦ 15.36TB using 4x 3.84TB 3.5-inch NVMe SSDs</li> </ul> </li> </ul>
Storage controllers	<ul style="list-style-type: none"> <li>• Onboard NVMe ports with optional RAID support using Intel VROC</li> <li>• NVMe RAID support using a Tri-mode RAID adapter</li> <li>• 12 Gb SAS/SATA RAID adapters, PCIe 4.0 or PCIe 3.0 host interface</li> <li>• 12 Gb SAS/SATA HBA (non-RAID), PCIe 4.0 or PCIe 3.0 host interface</li> </ul>
Optical drive bays	No internal optical drive.
Tape drive bays	No internal backup drive.
Network interfaces	Two dedicated OCP 3.0 SFF slots with a PCIe 5.0 host interface, either x8 or x16. Support a variety of 2-port and 4-port adapters with up to 400 GbE network connectivity. One port of each installed OCP adapter can optionally be shared with the XClarity Controller (XCC) management processor for Wake-on-LAN and NC-SI support.

Components	Specification
PCI Expansion slots	<p>Up to 10x slots, all at the rear, plus 2x OCP slots. All slots are PCIe 5.0. The use of Riser 3 and 4 requires 2 processors.</p> <ul style="list-style-type: none"> <li>• Riser 1: 2x low-profile slots, x8 or x16 (CPU 1)</li> <li>• Riser 2: 3x full-height slots, two x16 and one x8 (CPU 1)</li> <li>• Riser 3: 3x full-height slots, two x16 and one x8 (CPU 2)</li> <li>• Riser 4: 2x low-profile slots, x8 or x16 (CPU 2)</li> </ul> <p>Other slot configurations are available. See the <a href="#">I/O expansion</a> for details.</p> <p>The server also supports rear 2.5" or 3.5" drive bays, and rear hot-swap M.2 drives, instead of some slots. If the server has 8x 2.5-inch rear drive bays, then Riser 1 slots are full-height.</p> <p>All configurations include at the rear of the server:</p> <ul style="list-style-type: none"> <li>• 2x OCP slots with PCIe 5.0 x16 or x8 connection</li> </ul> <p>For 2.5-inch front drive configurations, the server supports the installation of a CFF RAID adapter or HBA in a dedicated area that does not consume any of the rear PCIe slots.</p>
GPU support	Support for up to 10x single-wide GPUs or 2x double-wide GPUs
Ports	<p>Front: External diagnostics port, optional 2x USB 3 (5 Gb/s) port, one supports XCC local management, optional Mini DisplayPort (miniDP) v1.1a video port.</p> <p>Rear: 2x USB 3 (5 Gb/s) ports, 1x VGA video port, 1x RJ-45 1GbE systems management port for XCC remote management. Optional DB-9 COM serial port (installs in a slot). Support for an optional second RJ-45 1GbE systems management port for XCC remote management (installs in OCP adapter slot). Support for an optional adapter to share an incoming remote management network connection across 4 servers (installs in an OCP slot).</p> <p>Internal: Optional 1x USB 3 (5 Gb/s) connector for operating system or license key purposes</p>
Cooling	6x (with two processors installed) or 5x (with one processor installed) single-rotor or dual-rotor hot swap 60 mm fans, configuration dependent. Fans are N+1 redundant, tolerating a single-rotor failure. One fan integrated in each power supply. For customers with water infrastructure in their data center, the server also supports open-loop water cooling for efficient heat removal.
Power supply	Up to two hot-swap redundant AC power supplies, 80 PLUS Platinum or 80 PLUS Titanium certification. 800W, 1300W, 2000W, 2700W and 3200W AC options. All AC power supplies support 230V power; some also support 115V input supply. In China only, all power supply options support 240 V DC. Support for HVDC and -48V DC power supply options.
Video	Embedded graphics with 16 MB memory with 2D hardware accelerator, integrated into the XClarity Controller 3 management controller. Two video ports (rear VGA and optional front Mini DisplayPort); both can be used simultaneously if desired. Maximum resolution is 1920x1200 32bpp at 60Hz.
Hot-swap parts	Drives, power supplies, and fans.
Systems management	Operator panel with status LEDs. Optional External Diagnostics Handset with LCD display. Clarity Controller 3 (XCC3) embedded management based on the ASPEED AST2600 baseboard management controller (BMC) and OpenBMC, XClarity Administrator centralized infrastructure delivery, XClarity Integrator plugins, and XClarity Energy Manager centralized server power management. Optional XCC3 Premier to enable remote control functions and other features.
Security features	Chassis intrusion switch, Power-on password, administrator's password, Root of Trust module supporting TPM 2.0 and Platform Firmware Resiliency (PFR). Optional lockable front security bezel.
Operating systems supported	Microsoft Windows Server, Red Hat Enterprise Linux, SUSE Linux Enterprise Server, VMware ESXi, Ubuntu Server. See the <a href="#">Operating system support</a> section for specifics.
Limited warranty	Three-year or one-year (model dependent) customer-replaceable unit and onsite limited warranty with 9x5 next business day (NBD).

Components	Specification
Service and support	Optional service upgrades are available through Lenovo Services: 4-hour or 2-hour response time, 6-hour fix time, 1-year or 2-year warranty extension, software support for Lenovo hardware and some third-party applications.
Dimensions	Width: 445 mm (17.5 in.), height: 87 mm (3.4 in.), depth: 796 mm (31.3 in.). See <a href="#">Physical and electrical specifications</a> for details.
Weight	Maximum weight: 38.8 kg (85.5 lb)

## Models

ThinkSystem SR650 V4 models can be configured by using the [Lenovo Data Center Solution Configurator \(DCSC\)](#).

Topics in this section:

- [CTO models](#)
- [CTO models for Windows 10 and Windows 11](#)
- [Base feature codes](#)
- [Preconfigured models](#)

### CTO models

ThinkSystem SR650 V4 models can be configured by using the [Lenovo Data Center Solution Configurator \(DCSC\)](#).

Preconfigured server models may also be available for the SR650 V4, however these are region-specific; that is, each region may define their own server models, and not all server models are available in every region.

The following table lists the base CTO models of the ThinkSystem SR650 V4 server.

Table 3. Base CTO models

Machine Type/Model	Description
7DGDCTO1WW	ThinkSystem SR650 V4 – 3-year warranty
7DGCCTO1WW	ThinkSystem SR650 V4 – 1-year warranty
7DLNCTO1WW	ThinkSystem SR650 V4 – SAP HANA configurations with 3-year warranty
7DGFCTO1WW	ThinkSystem SR650 V4 – vSAN configurations with 3-year warranty
7DGECTO1WW	ThinkSystem SR650 V4 – vSAN configurations with 1-year warranty

The SR650 V4 uses an additional machine type of 7DK2 for water-cooled servers using the Compute Complex Neptune Core Module, where memory is water-cooled in addition to the two CPUs, as listed in the following table.

Servers of machine type 7DK2 share components with machine types 7DGD, however the system board is different. Specifically, there are fewer DIMM slots and the DIMM slots are spaced wider apart to accommodate the heat-transfer components.

Table 4. Base CTO models for CPU+Memory water cooling

Machine Type/Model General purpose	Machine Type/Model for AI and HPC	Description
7DK2CTO1WW	-	ThinkSystem SR650 V4 CPU+DIMM DWC - 3yr Warranty

## CTO models for Windows 10 and Windows 11

The SR650 V4 can run Windows 10 and Windows 11, however only a subset of adapters and drives can be installed. For ease of configuration, the following Base CTO models have been announced to assist building a configuration that can be used with the client operating systems.

Table 5. Base CTO models for SR650 V4 with Windows 10 and Windows 11

Machine Type/Model	Description
7DGDCTO3WW	ThinkSystem SR650 V4 Workstation - 3 year Warranty
7DGCCTO3WW	ThinkSystem SR650 V4 Workstation - 1 year Warranty

## Base feature codes

Models of the SR650 V4 are defined based on the configuration of front drives. The feature codes for these chassis bases are as listed in the following table.

Table 6. Chassis base feature codes

Feature code	Description	Purpose
C3QL	ThinkSystem SR650 V4 12x3.5" Chassis	Configurations with front 3.5-inch hot-swap drives
C3QK	ThinkSystem SR650 V4 24x2.5" Chassis	Configurations with front 2.5-inch hot-swap drives
C3QM	ThinkSystem SR650 V4 EDSFF 3.S Chassis	Configurations with front E3.S drive bays

## Preconfigured models

The following tables list the available preconfigured models, grouped by region.

- [Models for Asia Pacific region](#)
- [Models for EMEA region](#)

Refer to the Specifications section for information about standard features of the server.

Common to all models:

- Power supplies are Platinum unless otherwise stated
- All models include a Toolless Slide Rail Kit

## Models for Asia Pacific region

The following table lists the models for the Asia Pacific region: Australia, Bangladesh, Brunei, Hong Kong, India, Japan, Korea, Sri Lanka, Malaysia, New Zealand, Philippines, Singapore, Thailand, Taiwan, Vietnam

Table 7. Models for Asia Pacific markets

Model	Intel Xeon Scalable processor†	Memory	RAID	Drive bays	OCP	Slots	Power supply	Fans	Internal USB	Front USB/DP	XCC3	Intru switch
Standard models with a 1-year warranty (machine type 7DGC)												
7DGCA00EAP	1x 6505P 12C 150W 2.2G	1x16GB	9350-8i	8x 2.5" SAS Open bay	1x 4x1G 5719	Slots 1&2: x8 LP, Slot 5 x16	2x 800W PT	5x Std	Y	Y	Std	Opt
TopSeller models with a 3-year warranty (machine type 7DGD)												
7DGDA00DAP	1x 6505P 12C 150W 2.2G	1x16GB	9350-16i	12x 3.5" SAS Open bay	1x 4x1G 5719	Slots 1&2: x8 LP, Slot 5 x16	2x 800W PT	5x Std	Y	Y	Std	Opt
7DGDA00FAP	1x 6505P 12C 150W 2.2G	1x16GB	9350-8i	8x 2.5" SAS Open bay	1x 4x1G 5719	Slots 1&2: x8 LP, Slot 5 x16	2x 800W PT	5x Std	Y	Y	Std	Opt
7DGDA00EAP	1x 6515P 16C 150W 2.4G	1x16GB	9350-16i	12x 3.5" SAS Open bay	1x 4x1G 5719	Slots 1&2: x8 LP, Slot 5 x16	2x 800W PT	5x Std	Y	Y	Std	Opt
7DGDA00HAP	1x 6515P 16C 150W 2.4G	1x16GB	9350-8i	8x 2.5" SAS Open bay	1x 4x1G 5719	Slots 1&2: x8 LP, Slot 5 x16	2x 800W PT	5x Std	Y	Y	Std	Opt

† Processor description: Processor model, number of cores, thermal design power (TDP), core frequency

## Models for EMEA region

Table 8. Models for EMEA region

Model	Intel Xeon Scalable processor†	Memory	RAID	Drive bays	OCP	Slots	Power supply	Fans	Internal USB	Front USB/DP	XCC3	Intru switch
Standard models with a 1-year warranty (machine type 7DGC)												
7DGCA00DEA	1x 6505P 12C 150W 2.2G	1x32GB 2Rx8	9350-8i	8x 2.5" SAS Open bay	Open	Slot 5 x16	1x800W TT Prem	5x Std	Opt	Opt	Pre	Yes
Standard models with a 3-year warranty (machine type 7DGD)												
7DGDA00JEA	1x 6505P 12C 150W 2.2G	1x32GB 2Rx8	9350-8i	8x 2.5" SAS Open bay	Open	Slot 5 x16	1x800W TT Prem	5x Std	Opt	Opt	Pre	Yes
7DGDA00NEA	1x 6505P 12C 150W 2.2G	1x32GB 2Rx8	940-8i 4GB	8x 2.5" SAS Open bay	Open	Slot 5 x16	1x1300W TT Prem	5x Std	Opt	Opt	Pre	Yes
7DGDA00UEA	1x 6505P 12C 150W 2.2G	4x64GB	940-8i 4GB	8x 2.5" SAS Open bay	Open	Slot 5 x16	1x1300W TT Prem	5x Std	Opt	Opt	Pre	Yes
7DGDA00KEA	1x 6507P 8C 150W 3.5G	1x32GB 2Rx8	9350-8i	8x 2.5" SAS Open bay	Open	Slot 5 x16	1x800W TT Prem	5x Perf	Opt	Opt	Pre	Yes
7DGDA00PEA	1x 6507P 8C 150W 3.5G	1x32GB 2Rx8	940-8i 4GB	8x 2.5" SAS Open bay	Open	Slot 5 x16	1x1300W TT Prem	5x Perf	Opt	Opt	Pre	Yes
7DGDA00VEA	1x 6507P 8C 150W 3.5G	4x64GB	940-8i 4GB	8x 2.5" SAS Open bay	Open	Slot 5 x16	1x1300W TT Prem	5x Perf	Opt	Opt	Pre	Yes
7DGDA00LEA	1x 6515P 16C 150W 2.4G	1x32GB 2Rx8	9350-8i	8x 2.5" SAS Open bay	Open	Slot 5 x16	1x800W TT Prem	5x Std	Opt	Opt	Pre	Yes

Model	Intel Xeon Scalable processor†	Memory	RAID	Drive bays	OCP	Slots	Power supply	Fans	Internal USB	Front USB/DP	XCC3	Intru switch
7DGDA00QEA	1x 6515P 16C 150W 2.4G	1x32GB 2Rx8	940-8i 4GB	8x 2.5" SAS Open bay	Open	Slot 5 x16	1x1300W TT Prem	5x Std	Opt	Opt	Pre	Yes
7DGDA00WEA	1x 6515P 16C 150W 2.4G	4x64GB	940-8i 4GB	8x 2.5" SAS Open bay	Open	Slot 5 x16	1x1300W TT Prem	5x Std	Opt	Opt	Pre	Yes
7DGDA014EA	1x 6515P 16C 150W 2.4G	4x64GB	940-8i 4GB	8x 2.5" SAS Open bay M.2 B540p Rear SATA/NVMe RAID, 2x 480GB ER3 M.2	Open	Slot 5 x16	1x1300W TT Prem	5x Std	Opt	Opt	Pre	Yes
7DGDA00MEA	1x 6517P 16C 190W 3.2G	1x32GB 2Rx8	9350-8i	8x 2.5" SAS Open bay	Open	Slot 5 x16	1x800W TT Prem	5x Std	Opt	Opt	Pre	Yes
7DGDA00REA	1x 6517P 16C 190W 3.2G	1x32GB 2Rx8	940-8i 4GB	8x 2.5" SAS Open bay	Open	Slot 5 x16	1x1300W TT Prem	5x Std	Opt	Opt	Pre	Yes
7DGDA00XEA	1x 6517P 16C 190W 3.2G	4x64GB	940-8i 4GB	8x 2.5" SAS Open bay	Open	Slot 5 x16	1x1300W TT Prem	5x Std	Opt	Opt	Pre	Yes
7DGDA00SEA	1x 6520P 24C 210W 2.4G	1x32GB 2Rx8	940-8i 4GB	8x 2.5" SAS Open bay	Open	Slot 5 x16	1x1300W TT Prem	5x Std	Opt	Opt	Pre	Yes
7DGDA00YEA	1x 6520P 24C 210W 2.4G	4x64GB	940-8i 4GB	8x 2.5" SAS Open bay	Open	Slot 5 x16	1x1300W TT Prem	5x Std	Opt	Opt	Pre	Yes
7DGDA010EA	1x 6527P 24C 255W 3.0G	4x64GB	940-8i 4GB	8x 2.5" SAS Open bay	Open	Slot 5 x16	1x1300W TT Prem	5x Std	Opt	Opt	Pre	Yes
7DGDA00TEA	1x 6530P 32C 225W 2.3G	1x32GB 2Rx8	940-8i 4GB	8x 2.5" SAS Open bay	Open	Slot 5 x16	1x1300W TT Prem	5x Std	Opt	Opt	Pre	Yes
7DGDA00ZEA	1x 6530P 32C 225W 2.3G	4x64GB	940-8i 4GB	8x 2.5" SAS Open bay	Open	Slot 5 x16	1x1300W TT Prem	5x Std	Opt	Opt	Pre	Yes
7DGDA015EA	1x 6530P 32C 225W 2.3G	4x64GB	940-8i 4GB	8x 2.5" SAS Open bay M.2 B540p Rear SATA/NVMe RAID, 2x 480GB ER3 M.2	Open	Slot 5 x16	1x1300W TT Prem	5x Std	Opt	Opt	Pre	Yes
7DGDA011EA	1x 6714P 8C 165W 4.0G	4x64GB	940-8i 4GB	8x 2.5" SAS Open bay	Open	Slot 5 x16	1x1300W TT Prem	5x Perf	Opt	Opt	Pre	Yes
7DGDA012EA	1x 6724P 16C 210W 3.6G	4x64GB	940-8i 4GB	8x 2.5" SAS Open bay	Open	Slot 5 x16	1x1300W TT Prem	5x Std	Opt	Opt	Pre	Yes
7DGDA013EA	1x 6737P 32C 270W 2.9G	1x32GB 2Rx8	9350-8i	8x 2.5" SAS Open bay	Open	Slot 5 x16	1x1300W TT Prem	5x Std	Opt	Opt	Pre	Yes

† Processor description: Processor model, number of cores, thermal design power (TDP), core frequency

## Processors

The SR650 V4 supports one or two of the following Intel processors:

- Intel Xeon 6500-series with P-cores (formerly "Granite Rapids" or GNR)
- Intel Xeon 6700-series with P-cores (formerly "Granite Rapids" or GNR)

Topics in this section:

- [Processor options](#)
- [Processor features](#)
- [Intel On Demand feature licensing](#)
- [One-processor configurations](#)
- [Processor cooling](#)
- [Lenovo Processor Neptune Core Module - Open-loop liquid cooling](#)
- [Lenovo Compute Complex Neptune Core Module - Open-loop liquid cooling](#)
- [UEFI operating modes](#)

## Processor options

The following table lists the Intel Xeon 6500 and 6700-series processors with P-cores that are supported by the SR650 V4.

**Compute Complex Neptune Core Module support:** As described in the [Lenovo Compute Complex Neptune Core Module - Open-loop liquid cooling](#) section, two processors are required. As a result, if you are configuring the SR650 V4 with machine type 7DK2, then the CPUs with a maximum quantity of only 1 processor are not supported.

Table 9. Intel Xeon 6500 and 6700 P-core processor support

Part number	Feature code	SKU	Description	Maximum quantity
Intel Xeon 6500-series with P-cores				
4XG7B03703	C5QQ	6505P	ThinkSystem SR650/a V4 Intel Xeon 6505P 12C 150W 2.2GHz Processor w/o fan	2
4XG7B03700	C5R6	6507P	ThinkSystem SR650/a V4 Intel Xeon 6507P 8C 150W 3.5GHz Processor w/o fan	2
CTO only	C5RB	6511P	Intel Xeon 6511P 16C 150W 2.3GHz Processor	1*
4XG7B03705	C5RD	6515P	ThinkSystem SR650/a V4 Intel Xeon 6515P 16C 150W 2.3GHz Processor w/o fan	2
4XG7B03701	C5QV	6517P	ThinkSystem SR650/a V4 Intel Xeon 6517P 16C 190W 3.2GHz Processor w/o fan	2
4XG7B03707	C5QR	6520P	ThinkSystem SR650/a V4 Intel Xeon 6520P 24C 210W 2.4GHz Processor w/o Fan	2
CTO only	C5R9	6521P	Intel Xeon 6521P 24C 225W 2.6GHz Processor	1*
4XG7B03696	C659	6527P	ThinkSystem SR650/a V4 Intel Xeon 6527P 24C 255W 3.1GHz Processor w/o Fan	2
4XG7B03691	C5QT	6530P	ThinkSystem SR650/a V4 Intel Xeon 6530P 32C 225W 2.3GHz Processor w/o Fan	2
Intel Xeon 6700-series with P-cores				
4XG7B03702	C5R7	6714P	ThinkSystem SR650/a V4 Intel Xeon 6714P 8C 165W 4.0GHz Processor w/o fan	2
4XG7B03704	C5R5	6724P	ThinkSystem SR650/a V4 Intel Xeon 6724P 16C 210W 3.6GHz Processor w/o fan	2
4XG7B03693	C5R4	6730P	ThinkSystem SR650/a V4 Intel Xeon 6730P 32C 250W 2.5GHz Processor w/o Fan	2
CTO only	C5QN	6731P	Intel Xeon 6731P 32C 245W 2.5GHz Processor	1*
4XG7B03698	C5R0	6736P	ThinkSystem SR650/a V4 Intel Xeon 6736P 36C 205W 2.0GHz Processor w/o Fan	2
4XG7B03706	C5QX	6737P	ThinkSystem SR650/a V4 Intel Xeon 6737P 32C 270W 2.9GHz Processor w/o Fan	2
4XG7B03695	C5R3	6740P	ThinkSystem SR650/a V4 Intel Xeon 6740P 48C 270W 1.9GHz Processor w/o Fan	2
CTO only	C5QU	6741P	Intel Xeon 6741P 48C 300W 2.5GHz Processor	1*
4XG7B03690	C5R8	6747P	ThinkSystem SR650/a V4 Intel Xeon 6747P 48C 330W 2.7GHz Processor w/o Fan	2
4XG7B03697	C5R1	6760P	ThinkSystem SR650/a V4 Intel Xeon 6760P 64C 330W 2.2GHz Processor w/o Fan	2
CTO only	C5QW	6761P	Intel Xeon 6761P 64C 350W 2.5GHz Processor	1*

Part number	Feature code	SKU	Description	Maximum quantity
4XG7B03692	C5QY	6767P	ThinkSystem SR650/a V4 Intel Xeon 6767P 64C 350W 2.4GHz Processor w/o Fan	2
CTO only	C5QP	6781P	Intel Xeon 6781P 80C 350W 2.0GHz Processor	1*
4XG7B03694	C5QM	6787P	ThinkSystem SR650/a V4 Intel Xeon 6787P 86C 350W 2.0GHz Processor w/o Fan	2

\* These processors are only supported in 1-socket configurations; configure-to-order (CTO) only, no field upgrades are supported, not supported with Compute Complex Neptune Core (machine type 7DK2)

## Processor features

Processors supported by the SR650 V4 include embedded accelerators to add even more processing capability:

- QuickAssist Technology (Intel QAT)  
Help reduce system resource consumption by providing accelerated cryptography, key protection, and data compression with Intel QuickAssist Technology (Intel QAT). By offloading encryption and decryption, this built-in accelerator helps free up processor cores and helps systems serve a larger number of clients.
- Intel Dynamic Load Balancer (Intel DLB)  
Improve the system performance related to handling network data on multi-core Intel Xeon Scalable processors. Intel Dynamic Load Balancer (Intel DLB) enables the efficient distribution of network processing across multiple CPU cores/threads and dynamically distributes network data across multiple CPU cores for processing as the system load varies. Intel DLB also restores the order of networking data packets processed simultaneously on CPU cores.
- Intel Data Streaming Accelerator (Intel DSA)  
Drive high performance for storage, networking, and data-intensive workloads by improving streaming data movement and transformation operations. Intel Data Streaming Accelerator (Intel DSA) is designed to offload the most common data movement tasks that cause overhead in data center-scale deployments. Intel DSA helps speed up data movement across the CPU, memory, and caches, as well as all attached memory, storage, and network devices.
- Intel In-Memory Analytics Accelerator (Intel IAA)  
Run database and analytics workloads faster, with potentially greater power efficiency. Intel In-Memory Analytics Accelerator (Intel IAA) increases query throughput and decreases the memory footprint for in-memory database and big data analytics workloads. Intel IAA is ideal for in-memory databases, open source databases and data stores like RocksDB, Redis, Cassandra, and MySQL.

The processors also support a separate and encrypted memory space, known as the SGX Enclave, for use by Intel Software Guard Extensions (SGX). The size of the SGX Enclave supported varies by processor model. Intel SGX offers hardware-based memory encryption that isolates specific application code and data in memory. It allows user-level code to allocate private regions of memory (enclaves) which are designed to be protected from processes running at higher privilege levels.

The following table summarizes the key features of the Intel Xeon 6500 and 6700 P-cores processors that are supported in the SR650 V4.

Table 10. Intel 6500 and 6700 P-core processor features

CPU model	Die	Cores/ threads	Core speed (Base / TB max)	L3 cache	Mem. chan	Max RDIMM speed	Max MRDIMM speed	UPI 2.0 links & speed	PCIe lanes	TDP	Accelerators				SGX Enclave Size
											QAT	DLB	DSA	IAA	
Intel Xeon 6500-series with P-cores															
6505P	LCC	12 / 24	2.2GHz / 4.1 GHz	48 MB	8	6400 MHz	None	4 / 24 GT/s	88	150W	2	2	2	2	128GB

CPU model	Die	Cores/ threads	Core speed (Base / TB max)	L3 cache	Mem. chan.	Max RDIMM speed	Max MRDIMM speed	UPI 2.0 links & speed	PCIe lanes	TDP					SGX Enclave Size
											QAT	DLB	DSA	IAA	
6507P	LCC	8 / 16	3.5GHz / 4.3 GHz	48 MB	8	6400 MHz	None	4 / 24 GT/s	88	150W	2	2	2	2	512GB
6511P	LCC	16 / 32	2.3GHz / 4.2 GHz	72 MB	8	6400 MHz	None	None‡	88	150W	2	2	2	2	128GB
6515P	LCC	16 / 32	2.3GHz / 3.8 GHz	72 MB	8	6400 MHz	None	4 / 24 GT/s	88	150W	2	2	2	2	128GB
6517P	LCC	16 / 32	3.2GHz / 4.2 GHz	72 MB	8	6400 MHz	None	4 / 24 GT/s	88	190W	2	2	2	2	512GB
6520P	HCC	24 / 48	2.4GHz / 4 GHz	144 MB	8	6400 MHz	None	4 / 24 GT/s	88	210W	2	2	2	2	128GB
6521P	HCC	24 / 48	2.6GHz / 4.1 GHz	144 MB	8	6400 MHz	None	None‡	88	225W	3	3	3	3	128GB
6527P	HCC	24 / 48	3.0GHz / 4.2 GHz	144 MB	8	6400 MHz	None	4 / 24 GT/s	88	255W	4	4	4	4	512GB
6530P	HCC	32 / 64	2.3GHz / 4.1 GHz	144 MB	8	6400 MHz	None	4 / 24 GT/s	88	225W	2	2	2	2	128GB
Intel Xeon 6700-series with P-cores															
6714P	LCC	8 / 16	4.0GHz / 4.3 GHz	48 MB	8	6400 MHz	None	4 / 24 GT/s	88	165W	2	2	2	2	512GB
6724P	LCC	16 / 32	3.6GHz / 4.3 GHz	72 MB	8	6400 MHz	None	4 / 24 GT/s	88	210W	2	2	2	2	512GB
6730P	HCC	32 / 64	2.5GHz / 3.8 GHz	288 MB	8	6400 MHz	None	4 / 24 GT/s	88	250W	4	4	4	4	512GB
6731P	HCC	32 / 64	2.5GHz / 4.1 GHz	144 MB	8	6400 MHz	None	None‡	88	245W	3	3	3	3	128GB
6736P	HCC	36 / 72	2.0GHz / 4.1 GHz	144 MB	8	6400 MHz	None	4 / 24 GT/s	88	205W	4	4	4	4	512GB
6737P	HCC	32 / 64	2.9GHz / 4 GHz	144 MB	8	6400 MHz	None	4 / 24 GT/s	88	270W	4	4	4	4	512GB
6740P	XCC	48 / 96	2.1GHz / 3.8 GHz	288 MB	8	6400 MHz	None	4 / 24 GT/s	88	270W	2	2	2	2	128GB
6741P	XCC	48 / 96	2.5GHz / 3.8 GHz	288 MB	8	6400 MHz	None	None‡	88	300W	3	3	3	3	128GB
6747P	XCC	48 / 96	2.7GHz / 3.9 GHz	288 MB	8	6400 MHz	8000 MHz	4 / 24 GT/s	88	330W	4	4	4	4	512GB
6760P	XCC	64 / 128	2.2GHz / 3.8 GHz	320 MB	8	6400 MHz	None	4 / 24 GT/s	88	330W	2	2	2	2	128GB
6761P	XCC	64 / 128	2.5GHz / 3.9 GHz	336 MB	8	6400 MHz	8000 MHz	None‡	88	350W	3	3	3	3	128GB
6767P	XCC	64 / 128	2.4GHz / 3.9 GHz	336 MB	8	6400 MHz	8000 MHz	4 / 24 GT/s	88	350W	4	4	4	4	512GB
6781P	XCC	80 / 160	2.0GHz / 3.8 GHz	336 MB	8	6400 MHz	8000 MHz	None‡	88	350W	3	3	3	3	128GB
6787P	XCC	86 / 172	2.0GHz / 3.8 GHz	336 MB	8	6400 MHz	8000 MHz	4 / 24 GT/s	88	350W	4	4	4	4	512GB

‡ These processors not have UPI links and are rich one-socket (R1S) processors

### Intel On Demand feature licensing

Intel Xeon 6 processors do not support Intel On Demand feature licensing for Accelerators.

## One-processor configurations

The SR650 V4 can be used with one processor installed. Most core functions of the server (including the XClarity Controller) are connected to processor 1 as shown in the [System architecture](#) section.

With only one processor, the server has the following capabilities:

- 16 memory DIMMs
- Riser 1 (slots 1 & 2) and Riser 2 (slots 3, 4, 5)
- OCP slot 1
- Up to 16x 2.5-inch NVMe drives using onboard NVMe connections (24x NVMe supported using Tri-Mode)
- Up to 16x E3.S 1T NVMe drives
- Up to 6x CXL memory modules in E3.S 2T drive bays
- Internal RAID adapter or HBA (CFF form factor)
- M.2 drives

## Processor cooling

The SR650 V4 offers four implementations to remove heat from the processors:

- Entry heatsinks, suitable for configurations that generate lower heat levels, and processors  $\leq 205W$
- Standard heatsinks with integrated heat pipes, suitable for configurations that generate lower heat levels, and processors  $\leq 330W$
- Performance heatsinks with separate radiator connected heat pipes, suitable for most configurations
- Open-loop liquid cooling of the processors, as described in the [Lenovo Processor Neptune Core Module](#) section
- Open-loop liquid cooling of the processors and memory, as described in the [Lenovo Compute Complex Neptune Core Module](#) section

For details about what configurations are supported with each, see the Thermal Rules section in the Lenovo Docs site for the SR650 V4:

[https://pubs.lenovo.com/sr650-v4/thermal\\_rules](https://pubs.lenovo.com/sr650-v4/thermal_rules)

Ordering information is listed in the following table.

Table 11. Processor cooling options

Feature code	Description	Purpose
Cooling options for machine types 7DGD and 7DGC		
BPDQ	ThinkSystem SR650 V3 AL Extrusion Entry Heatsink	Entry 2U heatsink. Automatically selected based on the server configuration.
BPDR	ThinkSystem V4 2U Standard Heatsink	Standard 2U heatsink. Automatically selected based on the server configuration.
C3QR	ThinkSystem V4 2U Performance Heatsink	Performance 2U heatsink. Automatically selected based on the server configuration.
C1XH	ThinkSystem V4 1U/2U Processor Neptune Core Module	Enables open-loop liquid cooling of the processors. See the <a href="#">Lenovo Processor Neptune Core Module</a> section.
Cooling options for machine type 7DK2 (CPU+Memory water cooling)		
C6AY	ThinkSystem V4 1U/2U Compute Complex Neptune Core Module	Enables open-loop liquid cooling of the processors, memory and voltage regulators. See the <a href="#">Lenovo Compute Complex Neptune Core Module</a> section.

## Lenovo Processor Neptune Core Module - Open-loop liquid cooling

The SR650 V4 also supports advanced direct-water cooling (DWC) capability with the Lenovo Processor Neptune Core Module. This module implements a liquid cooling solution where heat from the processors is removed from the rack and the data center using an open loop and coolant distribution units.

With the Processor Neptune Core Module, all heat generated by the processors is removed from the server using water. This means that the server fans and data center air conditioning units only need to remove the heat generated by the other components. This results in lower air conditioning costs and it enables the use of slower fans which results in lower overall power consumption.

Internal testing has shows a 63% fan power saving per node and 24.7% rack-level power saving with the use of open-loop liquid cooling. Power savings are configuration dependent.

The following figure shows the Lenovo Processor Neptune Core Module.

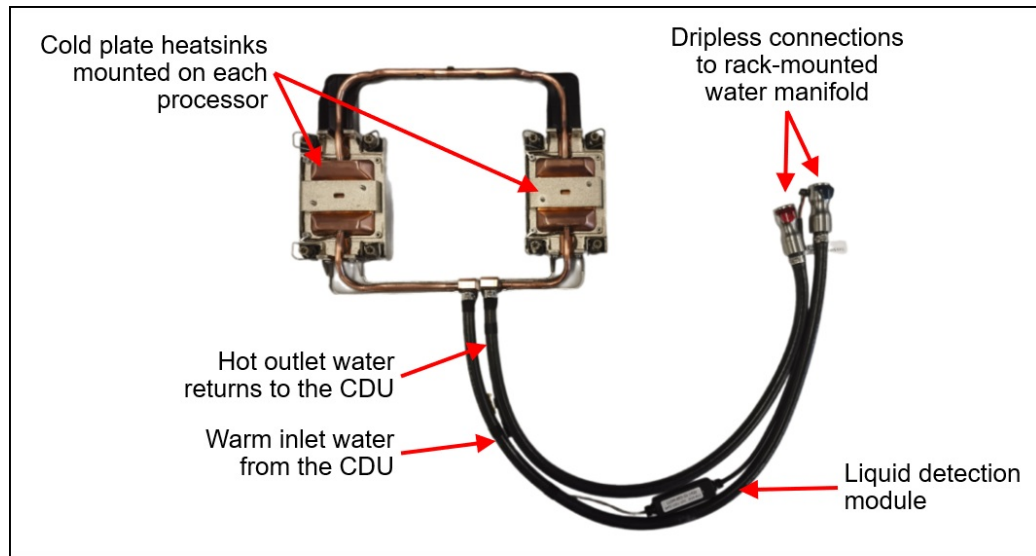

Figure 9. Lenovo Processor Neptune Core Module

The Processor Neptune Core Module also includes a leak detection module which can detect a leakage of more than 0.5ml (about 10 drops) along the length of the tube and then issue an event to the XClarity Controller. XCC will then post an error to the System Event Log and enable further actions. Once the liquid evaporates, a further event is issue to XCC.

The Processor Neptune Core Module is only available in CTO orders, not as a field upgrade. Ordering information is listed in the following table.

Table 12. Lenovo Processor Neptune Core Module

Part number	Feature code	Description
CTO only	C1XH*	ThinkSystem V4 1U/2U Processor Neptune Core Module

\* In DCSC, this feature code is listed in the Processor tab

Configuration notes:

- The Processor Neptune Core Module requires water infrastructure be available in the rack cabinet and data center, as described in the [Water infrastructure](#) section.
- All processor SKUs are supported
- Either one or two CPUs are supported
- All front drive bay configurations are supported
- Slot 8 is not available for adapters - the water loop is routed through the space otherwise occupied by slot

8

- Rear drive bays are supported
- M.2 adapters are supported based on the configurations in the [Storage configurations](#) section
- Standard fans can be configured in most configurations
- The use of a cable management arm (CMA) is not supported

For more information, see the Thermal Rules page:  
[https://pubs.lenovo.com/sr650-v4/thermal\\_rules](https://pubs.lenovo.com/sr650-v4/thermal_rules)

### Lenovo Compute Complex Neptune Core Module - Open-loop liquid cooling

The SR650 V4 also supports advanced direct-water cooling (DWC) of the processors, memory DIMMs, and voltage regulators (collectively called the compute complex) with the Lenovo Compute Complex Neptune Core Module. This heat is removed from the rack and the data center using an open loop and coolant distribution units.

With this solution, all heat generated by the compute complex is removed from the server using water, which means that the server fans and data center air conditioning units only need to remove the heat generated by the other components. This results in lower air conditioning costs and it enables the use of slower fans which results in lower overall power consumption.

Internal testing has shows an 92% fan power saving per node and 35.9% rack-level power saving with the use of open-loop liquid cooling. Power savings are configuration dependent. A rack cabinet with 20x SR650 V4 servers using 100% air cooling (PUE 1.6) requires 44.8 kW of data center power, including data center cooling costs, whereas 20x servers with Compute Complex Neptune Core Module with 80% liquid cooling (PUE 1.05) and 20% air cooling (PUE 1.6) requires 28.7 kW of data center power. This represents a 35.9% power saving at the rack level.

The following figure shows the Lenovo Compute Complex Neptune Core Module. The water flows past all DIMMs in parallel and then passes across both processors.

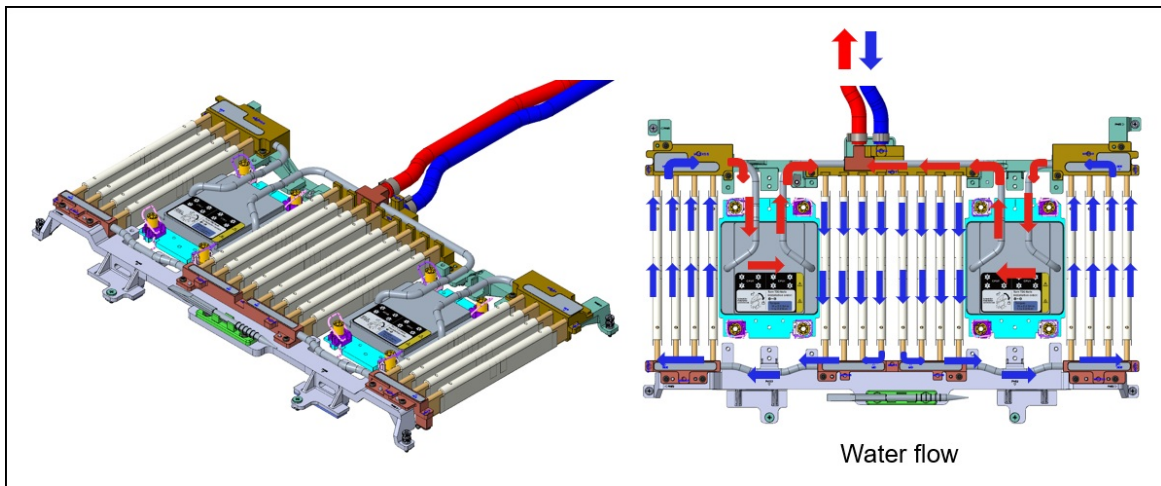

Figure 10. Lenovo Compute Complex Neptune Core Module

The Compute Complex Neptune Core Module also includes a leak detection module which can detect a leakage of more than 0.5ml (about 10 drops) along the length of the tube and then issue an event to the XClarity Controller. XCC will then post an error to the System Event Log and enable further actions. Once the liquid evaporates, a further event is issue to XCC.

The Compute Complex Neptune Core Module is only available in CTO orders, not as a field upgrade. The component listed in the following table will be automatically derived by the configurator when you build a server using machine type 7DK2 (see [Models](#) section).

Table 13. Compute Complex Neptune Core open-loop cooling

Part number	Feature code	Description
CTO only	C6AY	ThinkSystem V4 1U/2U Compute Complex Neptune Core Module

Configuration notes:

- The SR650 V4 must be configured using machine type 7DK2.
- The Compute Complex Neptune Core Module requires water infrastructure be available in the rack cabinet and data center, as described in the [Water infrastructure](#) section.
- Two processors are required; single-processor configurations are not supported
- All processor SKUs are supported except those that are only supported in 1-socket configurations
- Up to 16 DIMMs are supported, 8 per processor (1 DIMM per channel)
- Drive bay configurations are supported as listed in the the [Storage configurations](#) section.
- Slot 8 is not available for adapters - the water loop is routed through the space otherwise occupied by slot 8
- M.2 adapters are supported based on the configurations in the [Storage configurations](#) section
- Standard fans can be configured in most configurations
- The use of a cable management arm (CMA) is not supported

For more information, see the Thermal Rules page for the direct water cooling module:  
[https://pubs.lenovo.com/sr650-v4/thermal\\_rules](https://pubs.lenovo.com/sr650-v4/thermal_rules)

### UEFI operating modes

The SR650 V4 offers preset operating modes that affect energy consumption and performance. These modes are a collection of predefined low-level UEFI settings that simplify the task of tuning the server to suit your business and workload requirements.

The following table lists the feature codes that allow you to specify the mode you wish to preset in the factory for CTO orders.

**Limited choice for LCC processors:** If you select a processor with an LCC topology (see the Die column in the [Processor features](#) table), you will only be able to select General Computing - Power Efficiency (C3JB) in DCSC. The other modes are still supported, however, they can only be set in the field, not in the factory. Note that this is the only mode that is ERP Lot9-compliant for EU and UK customers.

Table 14. UEFI operating mode presets in DCSC

Feature code	Description
C3JB	General Computing - Power Efficiency (default)
C3JA	General Computing - Peak Frequency
C3J9	General Computing - Max Performance
C3J8	High Performance Computing (HPC)

The preset modes for the SR650 V4 are as follows:

- **General Computing - Power Efficiency** (feature C3JB): This workload profile optimizes the performance per watt efficiency with a bias towards performance. This workload profile is analogous to “Efficiency – Favor Performance” operating mode on ThinkSystem V3 servers. This profile contains settings for ENERGY STAR® and ERP Lot9 compliance.

- **General Computing - Peak Frequency** (feature C3JA): This workload profile is defined by the requirement to drive the highest core frequencies out of a processor across a subset of cores available – not for all cores active. This workload profile benefits workloads requiring either high per core and / or overall CPU package frequency. These workloads may have variable resource demands, are relatively insensitive to overall platform latency, and are generally CPU clock constrained. Tuning a system for highest possible core frequency may mean allowing inactive cores to transfer in and out of sleep states (C-states), which allows active cores to run at higher frequency for different durations of time. Allowing cores to go into low power states allows for higher per core frequency but can introduce “jitter” in the systems clock frequency.
- **General Computing - Max Performance** (feature C3J9): This workload profile maximizes the absolute performance of the system without regard for power savings. Power savings features are disabled. This operating mode should be used when an application can sustain work across all cores simultaneously and is Non-uniform Memory Access (NUMA) aware.
- **High Performance Computing (HPC)** (feature C3J8): This profile is for customers running large-scale scientific and engineering workloads. These environments tend to be clustered environments where each node performs at maximum utilization for extended periods of time, and the application is Non-uniform Memory Access (NUMA) aware.

## Memory

The SR650 V4 uses Lenovo TruDDR5 memory operating at up to 8000 MHz. The server supports up to 32 DIMMs with 2 processors. The processors have 8 memory channels and support 2 DIMMs per channel (DPC). The server supports up to 8TB of memory using 32x 256GB RDIMMs and two processors. The server also supports up to 12x CXL memory DIMMs (6 per CPU) which are installed in E3.S 2T drive bays.

DIMMs operate at the following speeds, up to the memory bus speed of the processor selected. See the [Processor features](#) section for specifics.

- RDIMMs and 3DS RDIMMs:
  - 1 DIMM per channel: Up to 6400 MHz
  - 2 DIMMs per channel using RDIMMs: Up to 5200 MHz
- MRDIMMs (support for MRDIMMs is processor-model dependent)
  - 1 DIMM per channel: 8000 MHz
- CXL 2.0 DIMMs - installs in E3.S 2T front drive bays
  - Up to 12 DIMMs per server (6 per CPU)

**Water-cooled memory:** The SR650 V4 can also be configured to implement water-cooling for installed memory DIMMs using the Lenovo Compute Complex Neptune Core Module. The server is limited to 16 DIMM slots (8 DIMMs per processor, 1 DIMM per channel). For more information see the [Lenovo Compute Complex Neptune Core Module](#) section.

Lenovo TruDDR5 memory uses the highest quality components that are sourced from Tier 1 DRAM suppliers and only memory that meets the strict requirements of Lenovo is selected. It is compatibility tested and tuned to maximize performance and reliability. From a service and support standpoint, Lenovo TruDDR5 memory automatically assumes the system warranty, and Lenovo provides service and support worldwide.

The following table lists the RDIMMs, 3DS RDIMMs, and MRDIMMs memory that are currently supported by the SR650 V4. These DIMMs are installed in the DIMM slots adjacent to the processors. The table also lists the supported quantities. The "CPU+Mem water cooled" DIMM quantity column is when the server is configured to use Lenovo Compute Complex Neptune Core Module for water-cooled memory.

Table 15. Memory options for DIMM slots

Part number	Feature code	Description	DRAM technology	Quantities supported per CPU (double for 2 CPUs)	
				P-cores CPUs	P-cores CPU+Mem water cooled
<b>x4 RDIMMs</b>					
4X77A90964	C0U9	ThinkSystem 32GB TruDDR5 6400MHz (1Rx4) RDIMM	16Gb	4, 8 per CPU	4, 8 per CPU
4X77A90966	C0TQ	ThinkSystem 64GB TruDDR5 6400MHz (2Rx4) RDIMM	16Gb	1, 4, 8, 16 per CPU	1, 4, 8 per CPU
4X77A90997	BZ7D	ThinkSystem 96GB TruDDR5 6400MHz (2Rx4) RDIMM	24Gb	8, 16 per CPU	8 per CPU
4X77A90993	C0U1	ThinkSystem 128GB TruDDR5 6400MHz (2Rx4) RDIMM	32Gb	8, 16 per CPU	8 per CPU
<b>x8 RDIMMs</b>					
4X77A90963	C0U2	ThinkSystem 16GB TruDDR5 6400MHz (1Rx8) RDIMM	16Gb	1, 4, 8 per CPU	1, 4, 8 per CPU
4X77A90965	BYTJ	ThinkSystem 32GB TruDDR5 6400MHz (2Rx8) RDIMM	16Gb	1, 4, 8, 12, 16 per CPU	1, 4, 8 per CPU
4X77A90996	BZ7C	ThinkSystem 48GB TruDDR5 6400MHz (2Rx8) RDIMM	24Gb	4, 8 per CPU	4, 8 per CPU
<b>MRDIMMs (operate at 8000 MHz in the SR650 V4) (Note: Not all processors support MRDIMMs - see <a href="#">Processor features</a>)</b>					
4X77A90998	C0TY	ThinkSystem 32GB TruDDR5 8800MHz (2Rx8) MRDIMM	-	8 per CPU	8 per CPU
4X77A90999	C0TX	ThinkSystem 64GB TruDDR5 8800MHz (2Rx4) MRDIMM	-	8 per CPU	8 per CPU

The following table lists the CXL memory that are currently supported by the SR650 V4. These memory options are installed in the front E3.S 2T drive bays at the front of the server.

**OS support for CXL:** CXL memory is not supported with Windows Server and VMware ESXi. See OSIG for specifics:

[https://lenovopress.lenovo.com/osig#servers=sr650-v4-xeon-6-p-cores-7dgc-7dgd-7dk2&os\\_families=microsoft-windows-server&os\\_families=vmware-esxi&support=all](https://lenovopress.lenovo.com/osig#servers=sr650-v4-xeon-6-p-cores-7dgc-7dgd-7dk2&os_families=microsoft-windows-server&os_families=vmware-esxi&support=all)

**VROC restriction with CXL memory :** VROC NVMe RAID is currently not supported with the following CXL memory configurations:

- Configurations with a mix of CXL memory (E3.S 2T) bays and E3.S 1T drive bays
- Configurations with CXL memory (E3.S 2T) bays and M.2 drives

CXL memory configurations without E3.S 1T drives or without M.2 drives are not affected and are supported. This restriction is planned to be removed with a firmware update planned for 2Q/2025.

Table 16. CXL memory options

Part number	Feature code	Description	Quantities supported per CPU (double for 2 CPUs)	
			P-cores CPUs	P-cores CPU+Mem water cooled
CXL DIMMs				
4X77A91000	C0TW	ThinkSystem 96GB E3.S 2T CXL DIMM	6 per CPU	No support
4X77A91001	C0TV	ThinkSystem 128GB E3.S 2T CXL DIMM	6 per CPU	No support

For servers that have a combination of DDR5 memory and CXL memory, you can specify how you want to the memory spaces to be presented to the operating system. For CTO orders, you can specify the factory to set the memory mode, as described in the table below. The memory mode can also be changed in UEFI at a later stage.

**Memory mirroring:** The use of memory mirroring is mutually exclusive with both of these modes.

Table 17. Interleaving choices for CTO orders (Memory tab in DCSC)

Part number	Feature code	Description	Purpose
CTO only	C8VB	DDR5 and (volatile) CXL Memory interleaved together in one 12-way set	This mode supports memory interleave between CXL memory and DDR memory. Interleaving of memory requests across a combination of native attach DDR5 channels and CXL-connected memory to increase aggregate bandwidth. The entire combined capacity of DDR memory and CXL memory is visible to the software as a single NUMA domain. As a result, no software changes are needed in the system to use heterogeneous interleave mode.
CTO only	C8VC	Native DDR5(1LM) and CXL Memory(volatile) visible to SW as separate tiers, separately interleaved	This is a 2-tier memory mode, where the DDR5 memory and CXL memory are different address spaces and separate NUMA nodes. This mode is also referred to as Software Managed tiering because the application must manage the placement of data in separate tiers and must manage any desired movement of data between tiers. This management of placement and movement may be performed by the OS, or by a higher-level middleware or directly by an application.

For more information on this memory, see the following Lenovo Press papers,

- [Introduction to DDR5 Memory](#)
- [Introduction to MRDIMM Memory Technology](#)
- [Introduction to CXL 2.0 Memory](#)

The following rules apply when specifying the memory configuration:

- The tables above list the supported quantities per processor. For two processors, install the same number of DIMMs to each processor. Other quantities are not supported.
- Only a subset of processors support MRDIMMs - see the table in the [Processor features](#) section for specifics.
- All installed DIMMs, except for CXL memory, must be identical part numbers; mixing not supported
- CXL memory can be mixed with the following RDIMMs

- ThinkSystem 64GB TruDDR5 6400MHz (2Rx4) RDIMM, 4X77A90966
  - ThinkSystem 96GB TruDDR5 6400MHz (2Rx4) RDIMM, 4X77A90997
  - ThinkSystem 128GB TruDDR5 6400MHz (2Rx4) RDIMM, 4X77A90993
- CXL memory is installed in E3.S 2T drive bays, however hot-swap functionality is not supported

For best performance, consider the following:

- Ensure the memory installed is at least the same speed as the memory bus of the selected processor.
- Populate all memory channels.

The following memory protection technologies are supported:

- ECC detection/correction
- Bounded Fault detection/correction
- SDDC (for 10x4-based memory DIMMs; look for "x4" in the DIMM description)
- ADDDC (for 10x4-based memory DIMMs)
- Memory mirroring

See the Lenovo Press article "RAS Features of the Lenovo ThinkSystem Intel Servers" for more information about memory RAS features: <https://lenovopress.lenovo.com/lp1711-ras-features-of-the-lenovo-thinksystem-intel-servers>

If memory channel mirroring is used, then DIMMs must be installed in pairs (minimum of one pair per processor), and both DIMMs in the pair must be identical in type and size. 50% of the installed capacity is available to the operating system.

Memory rank sparing is implemented using ADDDC/ADC-SR/ADDDC-MR to provide DRAM-level sparing feature support.

## Internal storage

The SR650 V4 has three drive bay zones and supports up to 16x 3.5-inch or 40x 2.5-inch hot-swap drive bays or a combination of drive bays, depending on the selected chassis and backplane configuration. The server also supports configurations with E3.S 1T and E3.S 2T drive bays including support for CXL memory in the E3.S 2T form factor. The server supports configurations without any drive bays if desired.

The three drive bay zones are as follows:

- Front:
  - Up to 12x 3.5-inch hot-swap bays, or
  - Up to 24x 2.5-inch hot-swap bays, or
  - Up to 32x E3.S 1T or 12x E3.S 2T hot-swap drive bays (or a mix of 1T/2T drive bays)
- Middle:
  - 8x 2.5-inch simple-swap bays
- Rear:
  - 4x 3.5-inch hot-swap bays, or
  - Up to 8x 2.5-inch hot-swap bays

The server also supports one or two M.2 drives, in three possible locations, configuration dependent:

- Installed in an M.2 adapter internal to the server (non-hot-swap)
- Hot-swap in the rear of the server
- Hot-swap in the front of the server

In this section:

- [NVMe drive support](#)
- [RAID 940 Tri-Mode support](#)
- [Front drive bays](#)
- [Mid drive bays](#)
- [Rear drive bays](#)
- [Storage configurations](#)
- [Field upgrades](#)
- [M.2 drives](#)
- [SED encryption key management with SKLM](#)

## NVMe drive support

The SR650 V4 supports NVMe drives to maximize storage performance.

- In a 2.5-inch drive configuration, the server supports up to 36 NVMe drives without oversubscription (that is, each x4 drive has a dedicated x4 (4 lanes) connection to the processor)
  - Up to 24 installed in front bays
  - Up to 28 installed in the front and rear bays
  - Up to 32 installed in front and mid bays
  - Up to 36 installed in front, mid and rear bays
- In a 3.5-inch drive configuration, the server supports up to 4x 3.5-inch NVMe or 8x 2.5-inch NVMe drives without oversubscription
- In a E3.S front drive configuration, the server supports up to 32x NVMe drives without oversubscription:
  - 32x E3.S 1T NVMe drives at the front
  - 12x E3.S 2T NVMe drives at the front
  - Combinations of E3.S 1T and 2T drive bays

In addition, the SR650 V4 supports two M.2 NVMe drives for use as boot drives, as described in the [M.2 drives](#) section

The specifics of these configurations are covered in the [Storage configurations](#) section. The tables in those sections indicate the number of NVMe drives in each configuration. The storage configuration tables also include a column that indicates the number of PCIe slots that are available.

The number of NVMe drives affects the number of PCIe slots that are available, as listed in the following tables. This is because the onboard PCIe MCIO connectors are used for both slots and NVMe drives.

Table 18. PCIe slot availability based on 3.5-inch NVMe or AnyBay drive bays configured

3.5-inch NVMe/AnyBay drive bays selected	Maximum rear PCIe slots
8 drive bays	10 slots (+ 2 OCP slots)
4 drive bays	10 slots (+ 2 OCP slots)

Table 19. PCIe slot availability based on 2.5-inch NVMe or AnyBay drive bays configured

2.5-inch NVMe/AnyBay drive bays selected	Maximum rear PCIe slots
36 drive bays (24 front, 8 mid, 4 rear)	1 slot (+ 2 OCP slots)
32 drive bays (24 front, 8 mid)	2 slots (+ 2 OCP slots)
28 drive bays (24 front, 4 rear)	2 slots (+ 2 OCP slots)
24 drive bays (all front)	4 slots (+ 2 OCP slots)
16 drive bays (all front)	6 slots (+ 2 OCP slots)
8 drive bays (all front)	10 slots (+ 2 OCP slots)

Table 20. PCIe slot availability based on E3.S 1T drive bays configured

E3.S 1T drive bays selected	Maximum rear PCIe slots
32 drive bays	2 slots (+ 2 OCP slots)
28 drive bays	2 slots (+ 2 OCP slots)
24 drive bays	4 slots (+ 2 OCP slots)
20 drive bays	4 slots (+ 2 OCP slots)
16 drive bays	6 slots (+ 2 OCP slots)
12 drive bays	6 slots (+ 2 OCP slots)
8 drive bays	10 slots (+ 2 OCP slots)

### RAID 940 Tri-Mode support

The RAID 940-8i and RAID 940-16i adapters also support NVMe through a feature named Tri-Mode support (or Trimode support). This feature enables the use of NVMe U.3 drives at the same time as SAS and SATA drives. Tri-Mode requires an AnyBay backplane. Cabling of the controller to the backplanes is the same as with SAS/SATA drives, and the NVMe drives are connected via a PCIe x1 link to the controller.

NVMe drives connected using Tri-Mode support provide better performance than SAS or SATA drives: A SATA SSD has a data rate of 6Gbps, a SAS SSD has a data rate of 12Gbps, whereas an NVMe U.3 Gen 4 SSD with a PCIe x1 link will have a data rate of 16Gbps. NVMe drives typically also have lower latency and higher IOPS compared to SAS and SATA drives. Tri-Mode is supported with U.3 NVMe drives and requires an AnyBay backplane.

**Tri-Mode requires U.3 drives:** Only NVMe drives with a U.3 interface are supported. U.2 drives are not supported. See the [Internal drive options](#) section for the U.3 drives supported by the server.

## Front drive bays

The front drive bay zone supports the following configurations:

- 8x or 12x 3.5-inch drive bays (hot-swap)
- 8x, 16x or 24x 2.5-inch drive bays (hot-swap)
- Up to 32x E3.S 1T drive bays (hot-swap)
- Up to 12x E3.S 2T drive bays for CXL memory (non-hot-swap)
- No backplanes and no drives (supports [field upgrades](#))

The specific combinations that are supported in the SR650 V4 are shown in the following figures. The feature codes listed are the backplane feature codes when ordering CTO and correspond to the feature codes listed in the table below the figure.

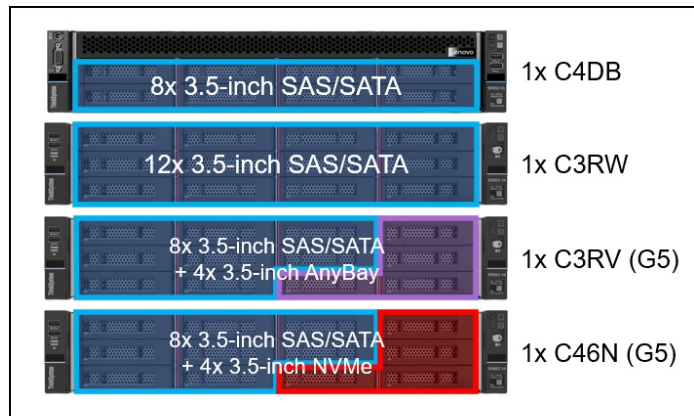

Figure 11. SR650 V4 front drive bay configurations - 3.5-inch drive bays

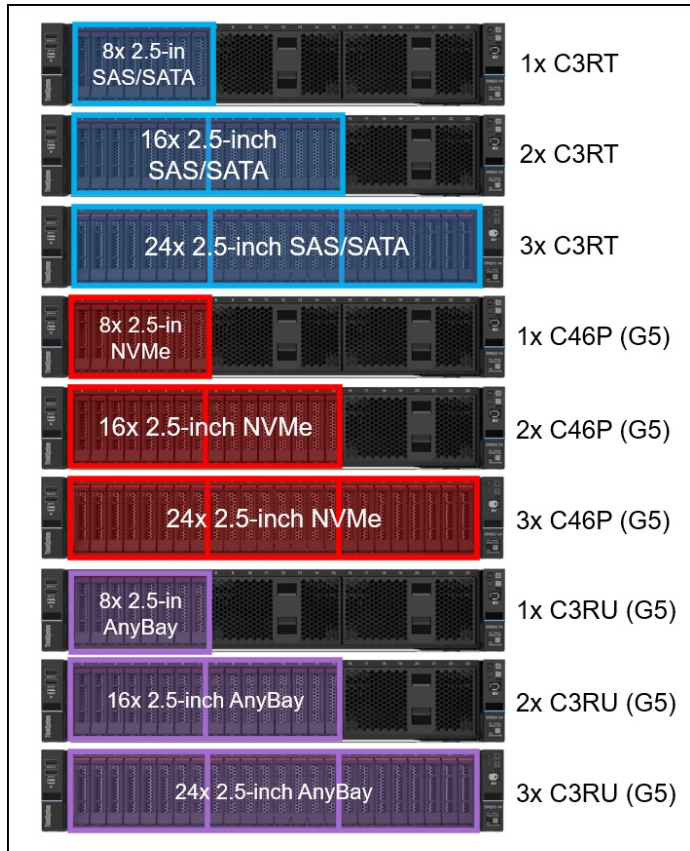

Figure 12. SR650 V4 front drive bay configurations - 2.5-inch drive bays, all the same drive type

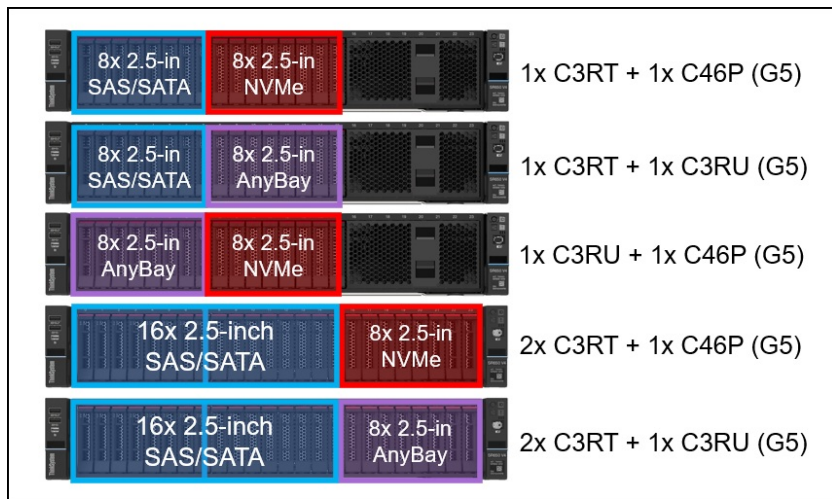

Figure 13. SR650 V4 front drive bay configurations - 2.5-inch drive bays, combinations

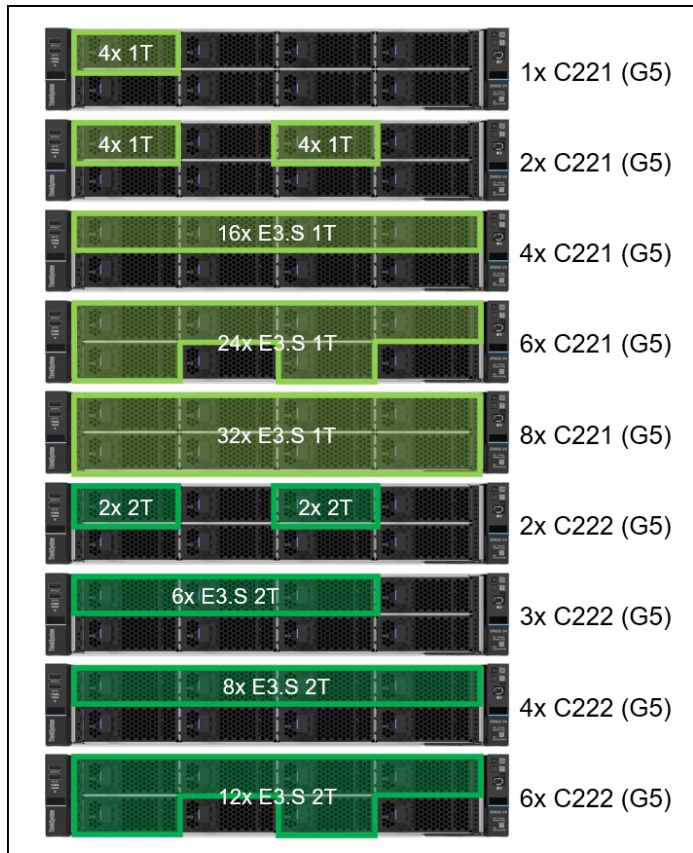

Figure 14. SR650 V4 front drive bay configurations - E3.S drive bays, all the same drive type

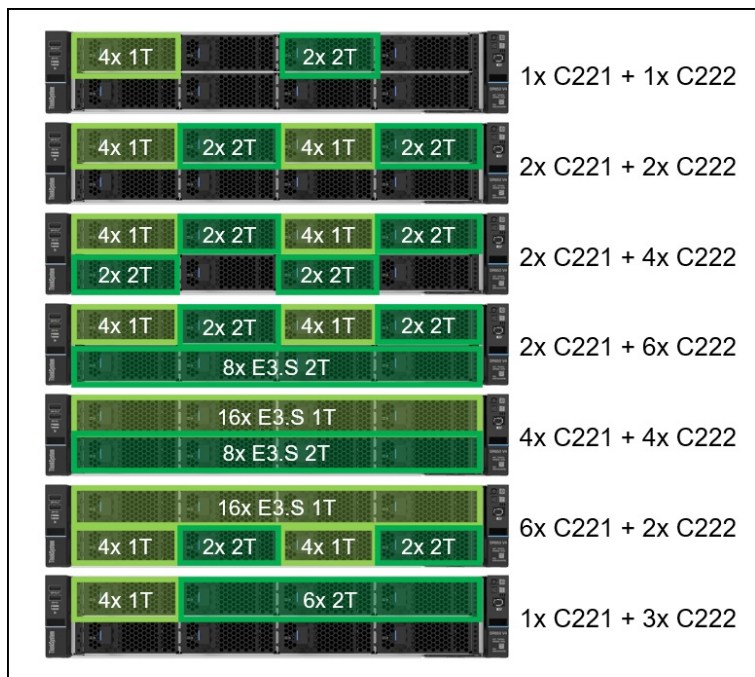

Figure 15. SR650 V4 front drive bay configurations - E3.S drive bays, combinations

The backplanes used to provide these drive bays are listed in the following table.

**Field upgrades:** All front backplanes are available as part numbers for field upgrades along with require cable option kits, as described in the [Field upgrades](#) section below.

Table 21. Backplanes for front drive bays

Feature	Description	Bays	PCIe Gen	SAS Gen	Max qty
Front 3.5-inch drive backplanes (requires base feature C3QL - see <a href="#">Base feature codes</a> section)					
C4DB	ThinkSystem 2U V4 8x3.5" SAS/SATA Backplane	8	-	12Gb	1
C3RW	ThinkSystem 2U V4 12x3.5" SAS/SATA Backplane	12	-	12Gb	1
C3RV	ThinkSystem 2U V4 8x3.5" SAS/SATA+4x 3.5" AnyBay Backplane	12	Gen5	24Gb	1
C46N	ThinkSystem 2U V4 8x3.5" SAS/SATA+4x 3.5" NVMe Backplane	12	Gen5	24Gb	1
Front 2.5-inch drive backplanes (requires base feature C3QK - see <a href="#">Base feature codes</a> section)					
C3RT	ThinkSystem 2U V4 8x2.5" SAS/SATA Backplane	8	-	12Gb	3
C3RU	ThinkSystem 2U V4 1x8x2.5" SAS/SATA/NVME Front Backplane	8	Gen5	24Gb	3
C46P	ThinkSystem 2U V4 8x2.5" NVMe Backplane	8	Gen5	-	3
Front E3.S drive backplanes (requires base feature C3QM - see <a href="#">Base feature codes</a> section)					
C221	ThinkSystem V4 EDSFF E3.S 4x1T NVMe Gen5 Backplane	4	Gen5	-	8
C222	ThinkSystem V4 EDSFF E3.S 2x2T NVMe Gen5 Backplane	2	Gen5	-	8

The use of front drive bays has the following configuration rules:

- The SR650 V4 also supports configurations without any drive bays, allowing for drive bay upgrades as described in the [field upgrades](#) section.
- If 3.5-inch front drive bays are used, an internal (CFF) RAID adapter or HBA is not supported as the adapter and bays occupy the same physical space
- Any of the following front drive configurations can be configured with front-mounted hot-swap M.2 drives, as described in the [M.2 drives](#) section:
  - Any 8x 2.5-inch and 16x 2.5-inch drive configuration (SAS/SATA, AnyBay, or NVMe)
  - Any E3.S configuration with 6 or fewer backplanes

### Mid drive bays

The SR650 V4 supports simple-swap drives installed in the middle of the server chassis. The drive bays are accessible by removing the top lid of the server and levering the mid drive chassis up at the front.

The following configurations are supported:

- 8x 2.5-inch simple-swap SAS/SATA drive bays
- 8x 2.5-inch simple-swap NVMe drive bays

The drive bays in the open position are shown in the following figure.

**Simple-swap drive bays:** The drives that are installed in the mid-chassis drive bays are simple-swap, not hot-swap, even though the drives use hot-swap drive trays.

**M.2 support:** When mid drive bays are configured, the M.2 adapter is installed on the mid drive bay mechanical as shown in the images.

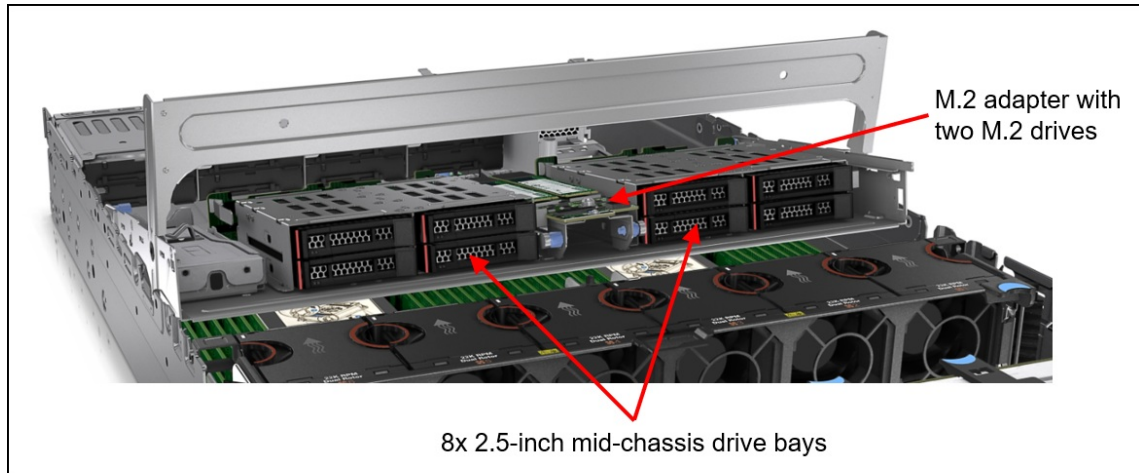

Figure 16. Mid-chassis drive bays

The backplanes used to provide these drive bays are listed in the following table.

Table 22. Backplanes for mid-chassis drive bays

Feature	Description	Bays	PCIe Gen	SAS Gen	Max qty
Mid - 2.5-inch drive backplane					
C46L	ThinkSystem 2U V4 Mid 4x2.5" SAS/SATA Backplane	4	-	24Gb	2
C46J	ThinkSystem 2U V4 Middle 4x2.5" NVMe Gen5 Backplane	4	Gen5	-	2

‡ 2.5-inch drive backplanes for the mid-chassis area must be installed in pairs. NVMe and SAS/SATA cannot be mixed.

**Field upgrades:** Backplanes are available as part numbers for field upgrades along with require cable option kits, as described in the [Field upgrades](#) section below.

The use of drive bays in the mid-chassis area has the following configuration rules:

- All processors are supported. Higher TDP processors will require the performance heatsinks.
- Full-length adapter cards are not supported
- GPUs (including low profile GPUs such as the NVIDIA L4) are not supported
- The mid drive bays and slots 2 & 10 share the same power connectors, so mid drive bays are mutually exclusive with slots 2 and 10. The only exception to this is config 27 with 8x mid drives and 8x rear drives - this configuration also supports slots 1 & 2.

### Rear drive bays

The SR650 V4 supports hot-swap drives installed at the rear of the server chassis. Supported configurations are as follows:

- 3.5-inch hot-swap drives
  - 4x SAS/SATA drive bays
- 2.5-inch hot-swap drives
  - 4x SAS/SATA drive bays
  - 4x NVMe Gen5 drive bays
  - 4x AnyBay Gen5 drive bays
  - 8x SAS/SATA drive bays

The configurations are shown in the following figure.

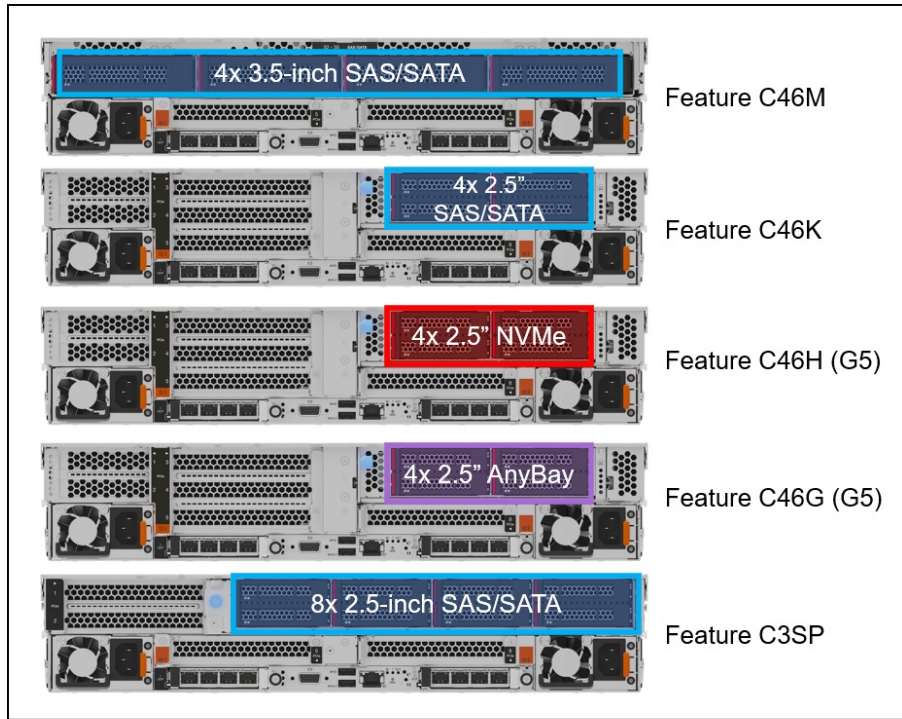

Figure 17. Rear 2.5-inch and 3.5-inch drive bay configurations

The backplanes used to provide these drive bays are listed in the following table.

Table 23. Backplanes for rear drive bays

Feature	Description	Bays	PCIe Gen	SAS Gen	Max qty
Rear - 3.5-inch drive backplanes					
C46M	ThinkSystem 2U V4 Rear 4x3.5" SAS/SATA Backplane	4	-	24Gb	1
Rear - 2.5-inch drive backplanes					
C46K	ThinkSystem 2U V4 Rear 4x2.5" SAS/SATA Backplane	4	-	24Gb	1
C46H	ThinkSystem 2U V4 Rear 4x2.5" NVMe Gen5 Backplane	4	Gen5	24Gb	1
C46G	ThinkSystem 2U V4 Rear 4x2.5"AnyBay Gen5 Backplane	4	Gen5	24Gb	1
C3SP	ThinkSystem 2U V4 Rear 8x2.5" SAS/SATA Backplane	8	-	12Gb	1

**Field upgrades:** Backplanes are available as part numbers for field upgrades along with require cable option kits, as described in the [Field upgrades](#) section below.

The use of rear drive bays has the following configuration rules:

- The use of rear bays restricts the number of slots and the choice of risers that are supported. See the [I/O expansion](#) section for details.

## Storage configurations

This section describes the various combinations of front and rear drives that the server supports, as well as M.2 support.

**Tip:** These tables are based on Storage Configs v1.5

In this section the divided in two groups, configurations for machine types 7DGD and 7DGC (air cooled, closed loop cooling, open loop CPU-only cooling) and configurations for machine type 7DK2 (Compute Complex Neptune open-loop CPU+Memory cooling):

- [Overview of storage configs - 3.5-inch front drive bays](#)
- [Overview of storage configs - 2.5-inch front drive bays](#)
- [Overview of storage configs - E3.S front drive bays](#)
- [Overview of storage configs - Compute Complex Neptune Core](#)
- [Details of storage configs - 3.5-inch front drives](#)
- [Details of storage configs - 2.5-inch front drives](#)
- [Details of storage configs - E3.S front drives](#)
- [Details of storage configs - Compute Complex Neptune Core](#)

The following tables summarize the storage configurations for the SR650 V4. For details, including processor requirements, cooling options, M.2 support, and controller selections, see the Details tables.

### Overview of storage configs - 3.5-inch front drive bays

The following table summarizes the storage configurations with 3.5-inch front drives bays.

Jump down to the [details of the configurations](#) .

Return to [Storage configurations](#).

Table 24. Overview of storage configs - 3.5-inch front drive bays

Config	Total drives (NVMe)	Front drive bays					Mid drives		Rear drives					Backplanes
		SAS/SATA	AnyBay	NVMe	E3.S 1T	E3.S 2T	2.5" SAS/SATA	2.5" NVMe	3.5" SAS/SATA	2.5" SAS/SATA	2.5" NVMe	2.5" AnyBay		
35	12 (0)	12	0	0	0	0	0	0	0	0	0	0	12x3.5" SAS/SATA (C3RW)	
36	12 (4)	8	4	0	0	0	0	0	0	0	0	0	12x3.5" (8x SAS/SATA, 4x AnyBay G5) (C3RV)	
37	12 (4)	8	0	4	0	0	0	0	0	0	0	0	12x3.5" (8x SAS/SATA, 4x NVMe G5) (C46N)	
38	16 (0)	12	0	0	0	0	0	0	4	0	0	0	<b>Front:</b> 12x3.5" SAS/SATA (C3RW) <b>Rear:</b> 4x3.5" SAS/SATA (C46M)	
41	16 (4)	12	0	0	0	0	0	0	0	0	0	4	<b>Front:</b> 12x3.5" SAS/SATA (C3RW) <b>Rear:</b> 4x2.5" AnyBay G5 (C46G)	
42	20 (8)	12	0	0	0	0	0	8	0	0	0	0	<b>Front:</b> 12x3.5" SAS/SATA (C3RW) <b>Mid:</b> 2x 4x2.5" NVMe G5 (2x C46J)	
117	8 (0)	8	0	0	0	0	0	0	0	0	0	0	8x3.5" SAS/SATA (C4DB)	
118	16 (4)	12	0	0	0	0	0	0	0	0	4	0	<b>Front:</b> 12x3.5" SAS/SATA (C3RW) <b>Rear:</b> 4x2.5" NVMe G5 (C46H)	
122	16 (8)	8	4	0	0	0	0	0	0	0	4	0	<b>Front:</b> 12x3.5" (8x SAS/SATA, 4x AnyBay G5) (C3RV) <b>Rear:</b> 4x2.5" NVMe G5 (C46H)	

## Overview of storage configs - 2.5-inch front drive bays

The following table summarizes the storage configurations with 2.5-inch front drives bays.

Jump down to the [details of the configurations](#).

Return to [Storage configurations](#).

Table 25. Overview of storage configs - 2.5-inch front drive bays

Config	Total drives (NVMe)	Front drive bays					Mid drives		Rear drives			Backplanes
		SAS/SATA	AnyBay	NVMe	E3.S 1T	E3.S 2T	2.5" SAS/SATA	2.5" NVMe	3.5" SAS/SATA	2.5" SAS/SATA	2.5" NVMe	
1	8 (0)	8	0	0	0	0	0	0	0	0	0	8x2.5" SAS/SATA (C3RT)
2	8 (8)	0	0	8	0	0	0	0	0	0	0	8x2.5" NVMe G5 (C46P)
3	8 (8)	0	8	0	0	0	0	0	0	0	0	8x2.5" AnyBay G5 (C3RU)
5	8 (8)	0	8	0	0	0	0	0	0	0	0	8x2.5" AnyBay G5 (C3RU) (Tri-mode)
6	16 (0)	16	0	0	0	0	0	0	0	0	0	2x 8x2.5" SAS/SATA (2x C3RT)
7	16 (16)	0	0	16	0	0	0	0	0	0	0	2x 8x2.5" NVMe G5 (2x C46P)
8	16 (16)	0	8	8	0	0	0	0	0	0	0	8x2.5" AnyBay G5 (C3RU) + 8x2.5" NVMe G5 (C46P)
9	16 (8)	8	8	0	0	0	0	0	0	0	0	8x2.5" SAS/SATA (C3RT) + 8x2.5" AnyBay G5 (C3RU)
10	16 (8)	8	0	8	0	0	0	0	0	0	0	8x2.5" SAS/SATA (C3RT) + 8x2.5" NVMe G5 (C46P)
11	16 (16)	0	16	0	0	0	0	0	0	0	0	2x 8x2.5" AnyBay G5 (2x C3RU) (Tri-mode)
12	24 (0)	24	0	0	0	0	0	0	0	0	0	3x 8x2.5" SAS/SATA (3x C3RT)
13	24 (24)	0	0	24	0	0	0	0	0	0	0	3x 8x2.5" NVMe G5 (3x C46P)
14	24 (8)	16	8	0	0	0	0	0	0	0	0	2x 8x2.5" SAS/SATA (2x C3RT) + 8x2.5" AnyBay G5 (C3RU)
15	24 (8)	16	0	8	0	0	0	0	0	0	0	2x 8x2.5" SAS/SATA (2x C3RT) + 8x2.5" NVMe G5 (C46P)
16	24 (24)	0	24	0	0	0	0	0	0	0	0	3x 8x2.5" AnyBay G5 (3x C3RU) (Tri-mode)
17	28 (0)	24	0	0	0	0	0	0	4	0	0	<b>Front:</b> 3x 8x2.5" SAS/SATA (3x C3RT) <b>Rear:</b> 4x2.5" SAS/SATA (C46K)
18	28 (4)	24	0	0	0	0	0	0	0	0	4	<b>Front:</b> 3x 8x2.5" SAS/SATA (3x C3RT) <b>Rear:</b> 4x2.5" AnyBay G5 (C46G)
19	28 (8)	16	8	0	0	0	0	0	4	0	0	<b>Front:</b> 2x 8x2.5" SAS/SATA (2x C3RT) + 8x2.5" AnyBay G5 (C3RU) <b>Rear:</b> 4x2.5" SAS/SATA (C46K)
20	32 (0)	24	0	0	0	0	8	0	0	0	0	<b>Front:</b> 3x 8x2.5" SAS/SATA (3x C3RT) <b>Mid:</b> 2x 4x2.5" SAS/SATA (2x C46L)
21	32 (8)	16	8	0	0	0	8	0	0	0	0	<b>Front:</b> 2x 8x2.5" SAS/SATA (2x C3RT) + 8x2.5" AnyBay G5 (C3RU) <b>Mid:</b> 2x 4x2.5" SAS/SATA (2x C46L)
22	32 (8)	16	8	0	0	0	0	0	8	0	0	<b>Front:</b> 2x 8x2.5" SAS/SATA (2x C3RT) + 8x2.5" AnyBay G5 (C3RU) <b>Rear:</b> 8x2.5" SAS/SATA (C3SP)
23	32 (0)	24	0	0	0	0	0	0	8	0	0	<b>Front:</b> 3x 8x2.5" SAS/SATA (3x C3RT) <b>Rear:</b> 8x2.5" SAS/SATA (C3SP)
24	32 (32)	0	0	24	0	0	8	0	0	0	0	<b>Front:</b> 3x 8x2.5" NVMe G5 (3x C46P) <b>Mid:</b> 2x 4x2.5" NVMe G5 (2x C46J)
25	36 (36)	0	0	24	0	0	8	0	0	4	0	<b>Front:</b> 3x 8x2.5" NVMe G5 (3x C46P) <b>Mid:</b> 2x 4x2.5" NVMe G5 (2x C46J) <b>Rear:</b> 4x2.5" NVMe G5 (C46H)

Config	Total drives (NVMe)	Front drive bays					Mid drives		Rear drives					Backplanes
		SAS/SATA	AnyBay	NVMe	E3.S 1T	E3.S 2T	2.5" SAS/SATA	2.5" NVMe	3.5" SAS/SATA	2.5" SAS/SATA	2.5" NVMe	2.5" AnyBay		
26	36 (0)	24	0	0	0	0	8	0	0	4	0	0	<b>Front:</b> 3x 8x2.5" SAS/SATA (3x C3RT) <b>Mid:</b> 2x 4x2.5" SAS/SATA (2x C46L) <b>Rear:</b> 4x2.5" SAS/SATA (C46K)	
27	40 (0)	24	0	0	0	0	8	0	0	8	0	0	<b>Front:</b> 3x 8x2.5" SAS/SATA (3x C3RT) <b>Mid:</b> 2x 4x2.5" SAS/SATA (2x C46L) <b>Rear:</b> 8x2.5" SAS/SATA (C3SP)	
101	28 (28)	0	0	24	0	0	0	0	0	0	4	0	<b>Front:</b> 3x 8x2.5" NVMe G5 (3x C46P) <b>Rear:</b> 4x2.5" NVMe G5 (C46H)	
121	16 (16)	0	8	8	0	0	0	0	0	0	0	0	8x2.5" AnyBay G5 (C3RU) + 8x2.5" NVMe G5 (C46P)	

## Overview of storage configs - E3.S front drive bays

The following table summarizes the storage configurations with E3.S front drives bays.

Jump down to the [details of the configurations](#).

Return to [Storage configurations](#).

Table 26. Overview of storage configs - E3.S front drive bays

Config	Total drives (NVMe)	Front drive bays					Mid drives		Rear drives					Backplanes
		SAS/SATA	AnyBay	NVMe	E3.S 1T	E3.S 2T	2.5" SAS/SATA	2.5" NVMe	3.5" SAS/SATA	2.5" SAS/SATA	2.5" NVMe	2.5" AnyBay		
59	8 (8)	0	0	0	8	0	0	0	0	0	0	0	2x 4xE3.S 1T NVMe G5 (2x C221)	
60	16 (16)	0	0	0	16	0	0	0	0	0	0	0	4x 4xE3.S 1T NVMe G5 (4x C221)	
61	24 (24)	0	0	0	24	0	0	0	0	0	0	0	6x 4xE3.S 1T NVMe G5 (6x C221)	
62	32 (32)	0	0	0	32	0	0	0	0	0	0	0	8x 4xE3.S 1T NVMe G5 (8x C221)	
63	4 (4)	0	0	0	0	4	0	0	0	0	0	0	2x 2xE3.S 2T NVMe G5 (2x C222)	
64	8 (8)	0	0	0	0	8	0	0	0	0	0	0	4x 2xE3.S 2T NVMe G5 (4x C222)	
65	12 (12)	0	0	0	0	12	0	0	0	0	0	0	6x 2xE3.S 2T NVMe G5 (6x C222)	
66	6 (6)	0	0	0	4	2	0	0	0	0	0	0	4xE3.S 1T NVMe G5 (C221) + 2xE3.S 2T NVMe G5 (C222)	
67	12 (12)	0	0	0	8	4	0	0	0	0	0	0	2x 4xE3.S 1T NVMe G5 (2x C221) + 2x 2xE3.S 2T NVMe G5 (2x C222)	
68	16 (16)	0	0	0	8	8	0	0	0	0	0	0	2x 4xE3.S 1T NVMe G5 (2x C221) + 4x 2xE3.S 2T NVMe G5 (4x C222)	
69	20 (20)	0	0	0	8	12	0	0	0	0	0	0	2x 4xE3.S 1T NVMe G5 (2x C221) + 6x 2xE3.S 2T NVMe G5 (6x C222)	
70	20 (20)	0	0	0	16	4	0	0	0	0	0	0	4x 4xE3.S 1T NVMe G5 (4x C221) + 2x 2xE3.S 2T NVMe G5 (2x C222)	
71	24 (24)	0	0	0	16	8	0	0	0	0	0	0	4x 4xE3.S 1T NVMe G5 (4x C221) + 4x 2xE3.S 2T NVMe G5 (4x C222)	
72	28 (28)	0	0	0	24	4	0	0	0	0	0	0	6x 4xE3.S 1T NVMe G5 (6x C221) + 2x 2xE3.S 2T NVMe G5 (2x C222)	
102	4 (4)	0	0	0	0	4	0	0	0	0	0	0	2x 2xE3.S 2T NVMe G5 (2x C222)	
119	6 (6)	0	0	0	0	6	0	0	0	0	0	0	3x 2xE3.S 2T NVMe G5 (3x C222)	
120	10 (10)	0	0	0	4	6	0	0	0	0	0	0	4xE3.S 1T NVMe G5 (C221) + 3x 2xE3.S 2T NVMe G5 (3x C222)	

**VROC restriction with CXL memory** : VROC NVMe RAID is currently not supported with the following CXL memory configurations:

- Configurations with a mix of CXL memory (E3.S 2T) bays and E3.S 1T drive bays
- Configurations with CXL memory (E3.S 2T) bays and M.2 drives

CXL memory configurations without E3.S 1T drives or without M.2 drives are not affected and are supported. This restriction is planned to be removed with a firmware update planned for 2Q/2025.

## Overview of storage configs - Compute Complex Neptune Core

The following table summarizes the storage configurations for servers with the Lenovo Compute Complex Neptune Core open-loop water cooling. Drive configurations include 2.5-inch and E3.S front drives bays.

Jump down to the [details of the configurations](#).

Return to [Storage configurations](#).

Table 27. Overview of storage configs - Compute Complex Neptune Core

Config	Total drives (NVMe)	Front drive bays					Mid drives		Rear drives				Backplanes
		SAS/SATA	AnyBay	NVMe	E3.S 1T	E3.S 2T	2.5" SAS/SATA	2.5" NVMe	3.5" SAS/SATA	2.5" SAS/SATA	2.5" NVMe	2.5" AnyBay	
87	8 (8)	0	0	8	0	0	0	0	0	0	0	0	8x2.5" NVMe G5 (C46P)
88	8 (8)	0	8	0	0	0	0	0	0	0	0	0	8x2.5" AnyBay G5 (C3RU)
89	16 (16)	0	0	16	0	0	0	0	0	0	0	0	2x 8x2.5" NVMe G5 (2x C46P)
90	16 (16)	0	8	8	0	0	0	0	0	0	0	0	8x2.5" AnyBay G5 (C3RU) + 8x2.5" NVMe G5 (C46P)
91	16 (8)	8	8	0	0	0	0	0	0	0	0	0	8x2.5" SAS/SATA (C3RT) + 8x2.5" AnyBay G5 (C3RU)
92	16 (8)	8	0	8	0	0	0	0	0	0	0	0	8x2.5" SAS/SATA (C3RT) + 8x2.5" NVMe G5 (C46P)
97	8 (8)	0	0	0	8	0	0	0	0	0	0	0	2x 4xE3.S 1T NVMe G5 (2x C221)
98	16 (16)	0	0	0	16	0	0	0	0	0	0	0	4x 4xE3.S 1T NVMe G5 (4x C221)
103	8 (0)	8	0	0	0	0	0	0	0	0	0	0	8x2.5" SAS/SATA (C3RT)
104	8 (8)	0	8	0	0	0	0	0	0	0	0	0	8x2.5" AnyBay G5 (C3RU) (Tri-mode)
105	16 (0)	16	0	0	0	0	0	0	0	0	0	0	2x 8x2.5" SAS/SATA (2x C3RT)
106	16 (16)	0	16	0	0	0	0	0	0	0	0	0	2x 8x2.5" AnyBay G5 (2x C3RU) (Tri-mode)

## Details of storage configs - 3.5-inch front drives

The following table lists the detailed storage configurations with 3.5-inch front drives bays.

Go back to the [overview of the configurations](#).

Return to [Storage configurations](#).

The table also includes a **PCIe slots** column that indicates the number of slots available with each configuration. Mouse over the slot count to see the slot numbers. For details of the slots supported with each configuration, refer to the [Slot configurations](#) section.

Table 28. Details of storage configs - 3.5-inch front drives

Config	CPUs	CPU cooling			Front drive bays				Mid drives		Rear drives				Backplanes	M.2			Controllers	PCIe slots ?	
		Air cooled	Open loop CPUs	Open loop CPUs+Mem	SAS/SATA	AnyBay	NVMe	E3.S 1T	E3.S 2T	2.5" SAS/SATA	2.5" NVMe	3.5" SAS/SATA	2.5" SAS/SATA	2.5" NVMe		2.5" AnyBay	M.2 Internal	M.2 Rear HS			M.2 Front HS
35-1	1 or 2	Y	Y	N	12	0	0	0	0	0	0	0	0	0	0	12x3.5" SAS/SATA (C3RW)	Y	Y	N	(4350-16i or 9350-16i)	10
35-2	1 or 2	Y	Y	N													Y	Y	N	(440-16i or 940-16i)	10
36-1	1 or 2	Y	Y	N	8	4	0	0	0	0	0	0	0	0	12x3.5" (8x SAS/SATA, 4x AnyBay G5) (C3RV)	Y	Y	N	OB NVMe + (4350-16i or 9350-16i)	10	
36-2	1 or 2	Y	Y	N													Y	Y	N	OB NVMe + (440-16i or 940-16i)	10
37-1	1 or 2	Y	Y	N	8	0	4	0	0	0	0	0	0	0	12x3.5" (8x SAS/SATA, 4x NVMe G5) (C46N)	Y	Y	N	OB NVMe + (5350-8i or 9350-8i)	10	
37-2	1 or 2	Y	Y	N													Y	Y	N	OB NVMe + (545-8i or 940-8i)	10
38-1	1 or 2	Y	Y	N	12	0	0	0	0	0	4	0	0	0	Front: 12x3.5" SAS/SATA (C3RW) Rear: 4x3.5" SAS/SATA (C46M)	Y	Y	N	(4350-16i or 9350-16i)	2	
38-2	1 or 2	Y	Y	N													Y	Y	N	(440-16i or 940-16i)	2
41-1	2 only	Y	Y	N	12	0	0	0	0	0	0	0	0	4	Front: 12x3.5" SAS/SATA (C3RW) Rear: 4x2.5" AnyBay G5 (C46G)	Y	Y	N	Front: (4350-16i or 9350-16i) Rear: OB NVMe	6	
41-2	2 only	Y	Y	N													Y	Y	N	Front: (440-16i or 940-16i) Rear: OB NVMe	6
42-1	2 only	Y	Y	N	12	0	0	0	0	8	0	0	0	0	Front: 12x3.5" SAS/SATA (C3RW) Mid: 2x 4x2.5" NVMe G5 (2x C46J)	Y	Y	N	Front: (4350-16i or 9350-16i) Mid: OB NVMe	7	
42-2	2 only	Y	Y	N													Y	Y	N	Front: (440-16i or 940-16i) Mid: OB NVMe	7
117-1	1 or 2	Y	Y	N	8	0	0	0	0	0	0	0	0	0	8x3.5" SAS/SATA (C4DB)	Y	Y	N	(4350-16i or 9350-16i)	10	
117-2	1 or 2	Y	Y	N													Y	Y	N	(440-16i or 940-16i)	10
118-1	2 only	Y	Y	N	12	0	0	0	0	0	0	0	4	0	Front: 12x3.5" SAS/SATA (C3RW) Rear: 4x2.5" NVMe G5 (C46H)	Y	Y	N	Front: (4350-16i or 9350-16i) Rear: OB NVMe	6	
118-2	2 only	Y	Y	N													Y	Y	N	Front: (440-16i or 940-16i) Rear: OB NVMe	6
122-1	2 only	Y	Y	N	8	4	0	0	0	0	0	0	4	0	Front: 12x3.5" (8x SAS/SATA, 4x AnyBay G5) (C3RV) Rear: 4x2.5" NVMe G5 (C46H)	Y	Y	N	Front: OB NVMe + (4350-16i or 9350-16i) Rear: OB NVMe	6	
122-2	2 only	Y	Y	N													Y	Y	N	Front: OB NVMe + (440-16i or 940-16i) Rear: OB NVMe	6

**Details of storage configs - 2.5-inch front drives**

The following table lists the detailed storage configurations with 2.5-inch front drives bays.

Go back to the [overview of the configurations](#).

Return to [Storage configurations](#).

The table also includes a **PCIe slots** column that indicates the number of slots available with each configuration. Mouse over the slot count to see the slot numbers. For details of the slots supported with each configuration, refer to the [Slot configurations](#) section.

Table 29. Details of storage configs - 2.5-inch front drives

Config	CPUs	CPU cooling			Front drive bays						Mid drives		Rear drives		Backplanes	M.2			PCIe slots ?		
		Air cooled	Open loop CPUs	Open loop CPUs+Mem	SAS/SATA	AnyBay	NVMe	E3.S 1T	E3.S 2T	2.5" SAS/SATA	2.5" NVMe	3.5" SAS/SATA	2.5" SAS/SATA	2.5" NVMe		2.5" AnyBay	M.2 Internal	M.2 Rear HS		M.2 Front HS	Controllers
1-1	1 or 2	Y	Y	N	8	0	0	0	0	0	0	0	0	0	0	8x2.5" SAS/SATA (C3RT)	Y	Y	Y	(5350-8i or 9350-8i or 4350-16i or 9350-16i)	10
1-2	1 or 2	Y	Y	N													Y	Y	Y	(545-8i or 940-8i or 440-16i or 940-16i)	10
1-3	2 only	Y	Y	N													Y	Y	Y	(440-16i CFF or 940-16i CFF)	10
1-4	1 only	Y	Y	N													Y	Y	Y	(440-16i CFF or 940-16i CFF)	5
2-1	2 only	Y	Y	N	0	0	8	0	0	0	0	0	0	0	0	8x2.5" NVMe G5 (C46P)	Y	Y	Y	OB NVMe	10
2-2	1 only	Y	Y	N													Y	Y	Y	OB NVMe	3
3-1	2 only	Y	Y	N	0	8	0	0	0	0	0	0	0	0	0	8x2.5" AnyBay G5 (C3RU)	Y	Y	Y	OB NVMe + (5350-8i or 9350-8i or 4350-16i or 9350-16i)	10
3-2	2 only	Y	Y	N													Y	Y	Y	OB NVMe + (545-8i or 940-8i or 440-16i or 940-16i)	10
3-3	2 only	Y	Y	N													Y	Y	Y	OB NVMe + (440-16i CFF or 940-16i CFF)	9
3-4	1 only	Y	Y	N													Y	Y	Y	OB NVMe + (5350-8i or 9350-8i or 4350-16i or 9350-16i)	3
3-5	1 only	Y	Y	N													Y	Y	Y	OB NVMe + (545-8i or 940-8i or 440-16i or 940-16i)	3
3-6	1 only	Y	Y	N													Y	Y	Y	OB NVMe + (440-16i CFF or 940-16i CFF)	2
5-1	1 or 2	Y	Y	N	0	8	0	0	0	0	0	0	0	0	0	8x2.5" AnyBay G5 (C3RU) (Tri-mode)	Y	Y	Y	(940-8i or 940-16i) Tri-mode	10
5-2	2 only	Y	Y	N													Y	Y	Y	940-16i CFF Tri-mode	10
5-3	1 only	Y	Y	N													Y	Y	Y	940-16i CFF Tri-mode	5
6-1	1 or 2	Y	Y	N	16	0	0	0	0	0	0	0	0	0	0	2x 8x2.5" SAS/SATA (2x C3RT)	Y	Y	Y	2x (5350-8i or 9350-8i)	9
6-2	1 or 2	Y	Y	N													Y	Y	Y	2x (545-8i or 940-8i)	9
6-3	1 or 2	Y	Y	N													Y	Y	Y	(4350-16i or 9350-16i)	9
6-4	1 or 2	Y	Y	N													Y	Y	Y	(440-16i or 940-16i)	9

Config	CPUs	CPU cooling			Front drive bays				Mid drives				Rear drives				Backplanes	M.2			PCle slots ?
		Air cooled	Open loop CPUs	Open loop CPUs+Mem	SAS/SATA	AnyBay	NVMe	E3.S 1T	E3.S 2T	2.5" SAS/SATA	2.5" NVMe	3.5" SAS/SATA	2.5" SAS/SATA	2.5" NVMe	2.5" AnyBay	M.2 Internal		M.2 Rear HS	M.2 Front HS	Controllers	
6-5	2 only	Y	Y	N													Y	Y	Y	(440-16i CFF or 940-16i CFF)	9
6-6	1 only	Y	Y	N													Y	Y	Y	(440-16i CFF or 940-16i CFF)	5
7-1	2 only	Y	Y	N	0	0	16	0	0	0	0	0	0	0	0	0	Y	Y	Y	OB NVMe	6
7-2	1 only	Y	Y	N													Y	Y	Y	OB NVMe	1
8-1	2 only	Y	Y	N	0	8	8	0	0	0	0	0	0	0	0	0	Y	Y	Y	OB NVMe + (5350-8i or 9350-8i or 4350-16i or 9350-16i)	6
8-2	2 only	Y	Y	N													Y	Y	Y	OB NVMe + (545-8i or 940-8i or 440-16i or 940-16i)	6
8-3	2 only	Y	Y	N													Y	Y	Y	OB NVMe + (440-16i CFF or 940-16i CFF)	5
8-4	1 only	Y	Y	N													Y	Y	Y	OB NVMe + (5350-8i or 9350-8i or 4350-16i or 9350-16i)	1
8-5	1 only	Y	Y	N													Y	Y	Y	OB NVMe + (545-8i or 940-8i or 440-16i or 940-16i)	1
8-6	1 only	Y	Y	N													Y	Y	Y	OB NVMe + (440-16i CFF or 940-16i CFF)	0
9-1	2 only	Y	Y	N	8	8	0	0	0	0	0	0	0	0	0	0	Y	Y	Y	OB NVMe + 2x (5350-8i or 9350-8i)	10
9-2	2 only	Y	Y	N													Y	Y	Y	OB NVMe + 2x (545-8i or 940-8i)	10
9-3	2 only	Y	Y	N													Y	Y	Y	OB NVMe + (4350-16i or 9350-16i)	10
9-4	2 only	Y	Y	N													Y	Y	Y	OB NVMe + (440-16i or 940-16i)	10
9-5	2 only	Y	Y	N													Y	Y	Y	OB NVMe + (440-16i CFF or 940-16i CFF)	9
9-6	1 only	Y	Y	N													Y	Y	Y	OB NVMe + 2x (5350-8i or 9350-8i)	3
9-7	1 only	Y	Y	N													Y	Y	Y	OB NVMe + 2x (545-8i or 940-8i)	3
9-8	1 only	Y	Y	N													Y	Y	Y	OB NVMe + (4350-16i or 9350-16i)	3
9-9	1 only	Y	Y	N													Y	Y	Y	OB NVMe + (440-16i or 940-16i)	3
9-10	1 only	Y	Y	N													Y	Y	Y	OB NVMe + (440-16i CFF or 940-16i CFF)	2
10-1	2 only	Y	Y	N	8	0	8	0	0	0	0	0	0	0	0	0	Y	Y	Y	OB NVMe + (5350-8i or 9350-8i or 4350-16i or 9350-16i)	10
10-2	2 only	Y	Y	N													Y	Y	Y	OB NVMe + (545-8i or 940-8i or 440-16i or 940-16i)	10

Config	CPUs	CPU cooling			Front drive bays				Mid drives		Rear drives			Backplanes	M.2			PCle slots ?		
		Air cooled	Open loop CPUs	Open loop CPUs+Mem	SAS/SATA	AnyBay	NVMe	E3.S 1T	E3.S 2T	2.5" SAS/SATA	2.5" NVMe	3.5" SAS/SATA	2.5" SAS/SATA		2.5" NVMe	2.5" AnyBay	M.2 Internal		M.2 Rear HS	M.2 Front HS
10-3	2 only	Y	Y	N												Y	Y	Y	OB NVMe + (440-16i CFF or 940-16i CFF)	9
10-4	1 only	Y	Y	N												Y	Y	Y	OB NVMe + (5350-8i or 9350-8i or 4350-16i or 9350-16i)	3
10-5	1 only	Y	Y	N												Y	Y	Y	OB NVMe + (545-8i or 940-8i or 440-16i or 940-16i)	3
10-6	1 only	Y	Y	N												Y	Y	Y	OB NVMe + (440-16i CFF or 940-16i CFF)	2
11-1	1 or 2	Y	Y	N	0	16	0	0	0	0	0	0	0	0	2x 8x2.5" AnyBay G5 (2x C3RU) (Tri-mode)	Y	Y	Y	2x 940-8i Tri-mode	10
11-2	1 or 2	Y	Y	N												Y	Y	Y	940-16i Tri-mode	10
11-3	2 only	Y	Y	N												Y	Y	Y	940-16i CFF Tri-mode	10
11-4	1 only	Y	Y	N												Y	Y	Y	940-16i CFF Tri-mode	5
12-1	1 or 2	Y	Y	N	24	0	0	0	0	0	0	0	0	0	3x 8x2.5" SAS/SATA (3x C3RT)	Y	Y	N	3x (5350-8i or 9350-8i)	10
12-2	1 or 2	Y	Y	N												Y	Y	N	3x (545-8i or 940-8i)	10
12-3	1 or 2	Y	Y	N												Y	Y	N	(4350-16i or 9350-16i) + (5350-8i or 9350-8i)	10
12-4	1 or 2	Y	Y	N												Y	Y	N	(440-16i or 940-16i) + (545-8i or 940-8i)	10
12-5	2 only	Y	Y	N												Y	Y	N	(440-16i CFF or 940-16i CFF) + (545-8i or 940-8i)	10
12-6	1 only	Y	Y	N												Y	Y	N	(440-16i CFF or 940-16i CFF) + (545-8i or 940-8i)	5
13-1	2 only	Y	Y	N	0	0	24	0	0	0	0	0	0	0	3x 8x2.5" NVMe G5 (3x C46P)	Y	Y	N	OB NVMe	4
13-2	2 only	Y	Y	N												Y	Y	N	OB NVMe	4
14-1	2 only	Y	Y	N	16	8	0	0	0	0	0	0	0	0	2x 8x2.5" SAS/SATA (2x C3RT) + 8x2.5" AnyBay G5 (C3RU)	Y	Y	N	OB NVMe + 3x (5350-8i or 9350-8i)	10
14-2	2 only	Y	Y	N												Y	Y	N	OB NVMe + 3x (545-8i or 940-8i)	10
14-3	2 only	Y	Y	N												Y	Y	N	OB NVMe + (4350-16i or 9350-16i) + (5350-8i or 9350-8i)	10
14-4	2 only	Y	Y	N												Y	Y	N	OB NVMe + (440-16i or 940-16i) + (545-8i or 940-8i)	10
14-5	2 only	Y	Y	N												Y	Y	N	OB NVMe + (440-16i CFF or 940-16i CFF) + (545-8i or 940-8i)	9

Config	CPUs	CPU cooling			SAS/SATA	AnyBay	NVMe	Front drive bays		E3.S 1T	E3.S 2T	Mid drives		Rear drives			Backplanes	M.2			Controllers	PCIe slots ?
		Air cooled	Open loop CPUs	Open loop CPUs+Mem				2.5" SAS/SATA	2.5" NVMe			3.5" SAS/SATA	2.5" SAS/SATA	2.5" NVMe	2.5" AnyBay	M.2 Internal		M.2 Rear HS	M.2 Front HS			
14-6	1 only	Y	Y	N													Y	Y	N	OB NVMe + 3x (5350-8i or 9350-8i)	3	
14-7	1 only	Y	Y	N													Y	Y	N	OB NVMe + 3x (545-8i or 940-8i)	3	
14-8	1 only	Y	Y	N													Y	Y	N	OB NVMe + (4350-16i or 9350-16i) + (5350-8i or 9350-8i)	3	
14-9	1 only	Y	Y	N													Y	Y	N	OB NVMe + (440-16i or 940-16i) + (545-8i or 940-8i)	3	
14-10	1 only	Y	Y	N													Y	Y	N	OB NVMe + (440-16i CFF or 940-16i CFF) + (545-8i or 940-8i)	2	
15-1	2 only	Y	Y	N	16	0	8	0	0	0	0	0	0	0	0	0	2x 8x2.5" SAS/SATA (2x C3RT) + 8x2.5" NVMe G5 (C46P)	Y	Y	N	OB NVMe + 2x (5350-8i or 9350-8i)	10
15-2	2 only	Y	Y	N														Y	Y	N	OB NVMe + 2x (545-8i or 940-8i)	10
15-3	2 only	Y	Y	N														Y	Y	N	OB NVMe + (4350-16i or 9350-16i)	10
15-4	2 only	Y	Y	N														Y	Y	N	OB NVMe + (440-16i or 940-16i)	10
15-5	2 only	Y	Y	N														Y	Y	N	OB NVMe + (440-16i CFF or 940-16i CFF)	9
15-6	1 only	Y	Y	N														Y	Y	N	OB NVMe + 2x (5350-8i or 9350-8i)	3
15-7	1 only	Y	Y	N														Y	Y	N	OB NVMe + 2x (545-8i or 940-8i)	3
15-8	1 only	Y	Y	N														Y	Y	N	OB NVMe + (4350-16i or 9350-16i)	3
15-9	1 only	Y	Y	N														Y	Y	N	OB NVMe + (440-16i or 940-16i)	3
15-10	1 only	Y	Y	N														Y	Y	N	OB NVMe + (440-16i CFF or 940-16i CFF)	2
16-1	1 or 2	Y	Y	N	0	24	0	0	0	0	0	0	0	0	0	0	3x 8x2.5" AnyBay G5 (3x C3RU) (Tri-mode)	Y	Y	N	3x 940-8i Tri-mode	10
16-2	1 or 2	Y	Y	N														Y	Y	N	940-16i Tri-mode + 940-8i Tri-mode	10
16-3	2 only	Y	Y	N														Y	Y	N	940-16i CFF Tri-mode + 940-8i Tri-mode	10
16-4	1 only	Y	Y	N														Y	Y	N	940-16i CFF Tri-mode + 940-8i Tri-mode	5



Config	CPUs	CPU cooling			Front drive bays				Mid drives		Rear drives			Backplanes	M.2			PCle slots ?		
		Air cooled	Open loop CPUs	Open loop CPUs+Mem	SAS/SATA	AnyBay	NVMe	E3.S 1T	E3.S 2T	2.5" SAS/SATA	2.5" NVMe	3.5" SAS/SATA	2.5" SAS/SATA		2.5" NVMe	2.5" AnyBay	M.2 Internal		M.2 Rear HS	M.2 Front HS
18-4	2 only	Y	Y	N											Y	Y	N	<b>Front:</b> (440-16i or 940-16i) + (545-8i or 940-8i) <b>Rear:</b> (545-8i or 940-8i) + OB NVMe	6	
18-5	2 only	Y	Y	N											Y	Y	N	<b>Front:</b> 2x (4350-16i or 9350-16i) <b>Rear:</b> OB NVMe	6	
18-6	2 only	Y	Y	N											Y	Y	N	<b>Front:</b> 2x (440-16i or 940-16i) <b>Rear:</b> OB NVMe	6	
18-7	2 only	Y	Y	N											Y	Y	N	<b>Front:</b> (440-16i CFF or 940-16i CFF) + (545-8i or 940-8i) <b>Rear:</b> (545-8i or 940-8i) + OB NVMe	6	
18-8	2 only	Y	Y	N											Y	Y	N	<b>Front:</b> (440-16i CFF or 940-16i CFF) + (440-16i or 940-16i) <b>Rear:</b> OB NVMe	6	
19-3	2 only	Y	Y	N	16	8	0	0	0	0	0	4	0	0	<b>Front:</b> 2x 8x2.5" SAS/SATA (2x C3RT) + 8x2.5" AnyBay G5 (C3RU) <b>Rear:</b> 4x2.5" SAS/SATA (C46K)	Y	Y	N	<b>Front:</b> OB NVMe + (4350-16i or 9350-16i) + (5350-8i or 9350-8i) <b>Rear:</b> (5350-8i or 9350-8i)	6
19-4	2 only	Y	Y	N											Y	Y	N	<b>Front:</b> OB NVMe + (440-16i or 940-16i) + (545-8i or 940-8i) <b>Rear:</b> (545-8i or 940-8i)	6	
19-5	2 only	Y	Y	N											Y	Y	N	OB NVMe + 2x (4350-16i or 9350-16i)	6	
19-6	2 only	Y	Y	N											Y	Y	N	OB NVMe + 2x (440-16i or 940-16i)	6	
19-7	2 only	Y	Y	N											Y	Y	N	<b>Front:</b> OB NVMe + (440-16i CFF or 940-16i CFF) + (545-8i or 940-8i) <b>Rear:</b> (545-8i or 940-8i)	6	
19-8	2 only	Y	Y	N											Y	Y	N	OB NVMe + (440-16i CFF or 940-16i CFF) + (440-16i or 940-16i)	6	
19-9	1 only	Y	Y	N											Y	Y	N	<b>Front:</b> OB NVMe + (4350-16i or 9350-16i) + (5350-8i or 9350-8i) <b>Rear:</b> (5350-8i or 9350-8i)	3	

Config	CPUs	CPU cooling			Front drive bays				Mid drives		Rear drives			Backplanes	M.2			PCle slots ?		
		Air cooled	Open loop CPUs	Open loop CPUs+Mem	SAS/SATA	AnyBay	NVMe	E3.S 1T	E3.S 2T	2.5" SAS/SATA	2.5" NVMe	3.5" SAS/SATA	2.5" SAS/SATA		2.5" NVMe	2.5" AnyBay	M.2 Internal		M.2 Rear HS	M.2 Front HS
19-10	1 only	Y	Y	N											Y	Y	N	<b>Front:</b> OB NVMe + (440-16i or 940-16i) + (545-8i or 940-8i) <b>Rear:</b> (545-8i or 940-8i)	3	
19-11	1 only	Y	Y	N											Y	Y	N	OB NVMe + 2x (4350-16i or 9350-16i)	3	
19-12	1 only	Y	Y	N											Y	Y	N	OB NVMe + 2x (440-16i or 940-16i)	3	
19-13	1 only	Y	Y	N											Y	Y	N	<b>Front:</b> OB NVMe + (440-16i CFF or 940-16i CFF) + (545-8i or 940-8i) <b>Rear:</b> (545-8i or 940-8i)	2	
19-14	1 only	Y	Y	N											Y	Y	N	OB NVMe + (440-16i CFF or 940-16i CFF) + (440-16i or 940-16i)	2	
20-5	1 or 2	Y	Y	N	24	0	0	0	0	8	0	0	0	0	Y	Y	N	<b>Front:</b> 3x 8x2.5" SAS/SATA (3x C3RT) <b>Mid:</b> 2x 4x2.5" SAS/SATA (2x C46L)	2x (4350-16i or 9350-16i)	8
20-6	1 or 2	Y	Y	N										Y	Y	N	2x (440-16i or 940-16i)		8	
20-9	1 or 2	Y	Y	N										Y	Y	N	(5350-8i or 9350-8i or 4350-16i) + Exp CFF		8	
20-10	1 or 2	Y	Y	N										Y	Y	N	(545-8i or 940-8i) + Exp CFF		8	
20-11	2 only	Y	Y	N										Y	Y	N	(440-16i CFF or 940-16i CFF) + Exp CFF		8	
20-12	1 only	Y	Y	N										Y	Y	N	(440-16i CFF or 940-16i CFF) + Exp CFF		4	
21-5	2 only	Y	Y	N	16	8	0	0	0	8	0	0	0	0	Y	Y	N		<b>Front:</b> 2x 8x2.5" SAS/SATA (2x C3RT) + 8x2.5" AnyBay G5 (C3RU) <b>Mid:</b> 2x 4x2.5" SAS/SATA (2x C46L)	OB NVMe + 2x (4350-16i or 9350-16i)
21-6	2 only	Y	Y	N										Y	Y	N	OB NVMe + 2x (440-16i or 940-16i)	7		
21-9	1 only	Y	Y	N										Y	Y	N	OB NVMe + 2x (4350-16i or 9350-16i)	3		
21-10	1 only	Y	Y	N										Y	Y	N	OB NVMe + 2x (440-16i or 940-16i)	3		
22-5	2 only	Y	Y	N	16	8	0	0	0	0	0	0	8	0	Y	Y	N	<b>Front:</b> 2x 8x2.5" SAS/SATA (2x C3RT) + 8x2.5" AnyBay G5 (C3RU) <b>Rear:</b> 8x2.5" SAS/SATA (C3SP)	OB NVMe + 2x (4350-16i or 9350-16i)	4
22-6	2 only	Y	Y	N										Y	Y	N	OB NVMe + 2x (440-16i or 940-16i)		4	

Config	CPUs	CPU cooling			Front drive bays		Mid drives		Rear drives			Backplanes	M.2			Controllers	PCIe slots ?		
		Air cooled	Open loop CPUs	Open loop CPUs+Mem	SAS/SATA	AnyBay	NVMe	E3.S 1T	E3.S 2T	2.5" SAS/SATA	2.5" NVMe		3.5" SAS/SATA	2.5" SAS/SATA	2.5" NVMe			2.5" AnyBay	M.2 Internal
22-11	1 only	Y	Y	N										Y	Y	N	OB NVMe + 2x (4350-16i or 9350-16i)	3	
22-12	1 only	Y	Y	N										Y	Y	N	OB NVMe + 2x (440-16i or 940-16i)	3	
23-5	1 or 2	Y	Y	N	24	0	0	0	0	0	0	8	0	0	Y	Y	N	2x (4350-16i or 9350-16i)	4
23-6	1 or 2	Y	Y	N										Y	Y	N	2x (440-16i or 940-16i)	4	
23-15	1 or 2	Y	Y	N										Y	Y	N	<b>Front:</b> (5350-8i or 9350-8i or 4350-16i) + Exp CFF <b>Rear:</b> Exp CFF	3	
23-16	1 or 2	Y	Y	N										Y	Y	N	<b>Front:</b> (545-8i or 940-8i) + Exp CFF <b>Rear:</b> Exp CFF	3	
23-17	2 only	Y	Y	N										Y	Y	N	<b>Front:</b> (440-16i CFF or 940-16i CFF) + Exp CFF <b>Rear:</b> Exp CFF	3	
23-18	1 only	Y	Y	N										Y	Y	N	<b>Front:</b> (440-16i CFF or 940-16i CFF) + Exp CFF <b>Rear:</b> Exp CFF	3	
24-1	2 only	Y	Y	N	0	0	24	0	0	0	8	0	0	0	Y	Y	N	<b>Front:</b> 3x 8x2.5" NVMe G5 (3x C46P) <b>Mid:</b> 2x 4x2.5" NVMe G5 (2x C46J)	2
25-1	2 only	Y	Y	N	0	0	24	0	0	0	8	0	0	4	Y	Y	N	<b>Front:</b> 3x 8x2.5" NVMe G5 (3x C46P) <b>Mid:</b> 2x 4x2.5" NVMe G5 (2x C46J) <b>Rear:</b> 4x2.5" NVMe G5 (C46H)	1
26-1	1 or 2	Y	Y	N	24	0	0	0	0	8	0	0	4	0	Y	Y	N	(5350-8i or 9350-8i or 4350-16i) + Exp CFF	5
26-2	1 or 2	Y	Y	N										Y	Y	N	(545-8i or 940-8i) + Exp CFF	5	
26-3	2 only	Y	Y	N										Y	Y	N	<b>Front:</b> (440-16i CFF or 940-16i CFF) + Exp CFF <b>Rear:</b> Exp CFF	5	
26-4	1 only	Y	Y	N										Y	Y	N	<b>Front:</b> (440-16i CFF or 940-16i CFF) + Exp CFF <b>Rear:</b> Exp CFF	4	

Config	CPUs	CPU cooling			Front drive bays				Mid drives		Rear drives			Backplanes	M.2			Controllers	PCIe slots ?		
		Air cooled	Open loop CPUs	Open loop CPUs+Mem	SAS/SATA	AnyBay	NVMe	E3.S 1T	E3.S 2T	2.5" SAS/SATA	2.5" NVMe	3.5" SAS/SATA	2.5" SAS/SATA		2.5" NVMe	2.5" AnyBay	M.2 Internal			M.2 Rear HS	M.2 Front HS
27-1	1 or 2	Y	Y	N	24	0	0	0	0	8	0	0	8	0	0	<b>Front:</b> 3x 8x2.5" SAS/SATA (3x C3RT) <b>Mid:</b> 2x 4x2.5" SAS/SATA (2x C46L) <b>Rear:</b> 8x2.5" SAS/SATA (C3SP)	Y	Y	N	(5350-8i or 9350-8i or 4350-16i) + Exp CFF	4
27-2	1 or 2	Y	Y	N											Y		Y	N	(545-8i or 940-8i) + Exp CFF	4	
27-3	2 only	Y	Y	N											Y		Y	N	<b>Front:</b> (440-16i CFF or 940-16i CFF) + Exp CFF <b>Rear:</b> Exp CFF	4	
27-4	1 only	Y	Y	N											Y		Y	N	<b>Front:</b> (440-16i CFF or 940-16i CFF) + Exp CFF <b>Rear:</b> Exp CFF	4	
101-1	2 only	Y	Y	N	0	0	24	0	0	0	0	0	0	4	0	<b>Front:</b> 3x 8x2.5" NVMe G5 (3x C46P) <b>Rear:</b> 4x2.5" NVMe G5 (C46H)	Y	Y	N	<b>Front:</b> OB NVMe <b>Rear:</b> OB NVMe	2
121-1	2 only	Y	Y	N	0	8	8	0	0	0	0	0	0	0	8x2.5" AnyBay G5 (C3RU) + 8x2.5" NVMe G5 (C46P)		Y	Y	Y	OB NVMe + (5350-8i or 9350-8i or 4350-16i or 9350-16i)	6
121-2	2 only	Y	Y	N												Y	Y	Y	OB NVMe + (545-8i or 940-8i or 440-16i or 940-16i)	6	
121-3	2 only	Y	Y	N												Y	Y	Y	OB NVMe + (440-16i CFF or 940-16i CFF)	5	
121-4	1 only	Y	Y	N												Y	Y	Y	OB NVMe + (5350-8i or 9350-8i or 4350-16i or 9350-16i)	1	
121-5	1 only	Y	Y	N												Y	Y	Y	OB NVMe + (545-8i or 940-8i or 440-16i or 940-16i)	1	
121-6	1 only	Y	Y	N												Y	Y	Y	OB NVMe + (440-16i CFF or 940-16i CFF)	0	

### Details of storage configs - E3.S front drives

The following table lists the detailed storage configurations with E3.S front drives bays.

Go back to the [overview of the configurations](#).

Return to [Storage configurations](#).

The table also includes a **PCIe slots** column that indicates the number of slots available with each configuration. Mouse over the slot count to see the slot numbers. For details of the slots supported with each configuration, refer to the [Slot configurations](#) section.

Table 30. Details of storage configs - E3.S front drives

Config	CPUs	CPU cooling			Front drive bays					Mid drives		Rear drives				Backplanes	M.2			Controllers	PCIe slots ?
		Air cooled	Open loop CPUs	Open loop CPUs+Mem	SAS/SATA	AnyBay	NVMe	E3.S 1T	E3.S 2T	2.5" SAS/SATA	2.5" NVMe	3.5" SAS/SATA	2.5" SAS/SATA	2.5" NVMe	2.5" AnyBay		M.2 Internal	M.2 Rear HS	M.2 Front HS		
59-1	2 only	Y	Y	N	0	0	0	8	0	0	0	0	0	0	0	2x 4xE3.S 1T NVMe G5 (2x C221)	Y	Y	Y	OB NVMe	10
59-2	1 only	Y	Y	N													Y	Y	Y	OB NVMe	3
60-1	2 only	Y	Y	N	0	0	0	16	0	0	0	0	0	0	0	4x 4xE3.S 1T NVMe G5 (4x C221)	Y	Y	Y	OB NVMe	6
60-2	1 only	Y	Y	N													Y	Y	N	OB NVMe	1
61-1	2 only	Y	Y	N	0	0	0	24	0	0	0	0	0	0	0	6x 4xE3.S 1T NVMe G5 (6x C221)	Y	Y	Y	OB NVMe	4
62-1	2 only	Y	Y	N	0	0	0	32	0	0	0	0	0	0	0	8x 4xE3.S 1T NVMe G5 (8x C221)	Y	Y	N	OB NVMe	2
63-1	2 only	Y	Y	N	0	0	0	0	4	0	0	0	0	0	0	2x 2xE3.S 2T NVMe G5 (2x C222)	Y	Y	Y	OB NVMe	10
63-2	1 only	Y	Y	N													Y	Y	Y	OB NVMe	3
64-1	2 only	Y	Y	N	0	0	0	0	8	0	0	0	0	0	0	4x 2xE3.S 2T NVMe G5 (4x C222)	Y	Y	Y	OB NVMe	6
65-1	2 only	Y	Y	N	0	0	0	0	12	0	0	0	0	0	0	6x 2xE3.S 2T NVMe G5 (6x C222)	Y	Y	Y	OB NVMe	4
66-1	1 only	Y	Y	N	0	0	0	4	2	0	0	0	0	0	0	4xE3.S 1T NVMe G5 (C221) + 2xE3.S 2T NVMe G5 (C222)	Y	Y	Y	OB NVMe	3
67-1	2 only	Y	Y	N	0	0	0	8	4	0	0	0	0	0	0	2x 4xE3.S 1T NVMe G5 (2x C221) + 2x 2xE3.S 2T NVMe G5 (2x C222)	Y	Y	Y	OB NVMe	6
67-2	1 only	Y	Y	N													Y	Y	N	OB NVMe	1
68-1	2 only	Y	Y	N	0	0	0	8	8	0	0	0	0	0	0	2x 4xE3.S 1T NVMe G5 (2x C221) + 4x 2xE3.S 2T NVMe G5 (4x C222)	Y	Y	Y	OB NVMe	4
69-1	2 only	Y	Y	N	0	0	0	8	12	0	0	0	0	0	0	2x 4xE3.S 1T NVMe G5 (2x C221) + 6x 2xE3.S 2T NVMe G5 (6x C222)	Y	Y	N	OB NVMe	2
70-1	2 only	Y	Y	N	0	0	0	16	4	0	0	0	0	0	0	4x 4xE3.S 1T NVMe G5 (4x C221) + 2x 2xE3.S 2T NVMe G5 (2x C222)	Y	Y	Y	OB NVMe	4
71-1	2 only	Y	Y	N	0	0	0	16	8	0	0	0	0	0	0	4x 4xE3.S 1T NVMe G5 (4x C221) + 4x 2xE3.S 2T NVMe G5 (4x C222)	Y	Y	N	OB NVMe	2
72-1	2 only	Y	Y	N	0	0	0	24	4	0	0	0	0	0	0	6x 4xE3.S 1T NVMe G5 (6x C221) + 2x 2xE3.S 2T NVMe G5 (2x C222)	Y	Y	N	OB NVMe	2
102-1	1 only	Y	Y	N	0	0	0	0	4	0	0	0	0	0	0	2x 2xE3.S 2T NVMe G5 (2x C222)	Y	Y	N	OB NVMe	5
119-1	1 only	Y	Y	N	0	0	0	0	6	0	0	0	0	0	0	3x 2xE3.S 2T NVMe G5 (3x C222)	Y	Y	Y	OB NVMe	2

Config	CPUs	CPU cooling			Front drive bays				Mid drives		Rear drives			Backplanes	M.2			Controllers	PCIe slots ?		
		Air cooled	Open loop CPUs	Open loop CPUs+Mem	SAS/SATA	AnyBay	NVMe	E3.S 1T	E3.S 2T	2.5" SAS/SATA	2.5" NVMe	3.5" SAS/SATA	2.5" SAS/SATA		2.5" NVMe	2.5" AnyBay	M.2 Internal			M.2 Rear HS	M.2 Front HS
120-1	1 only	Y	Y	N	0	0	0	4	6	0	0	0	0	0	0	4xE3.S 1T NVMe G5 (C221) + 3x 2xE3.S 2T NVMe G5 (3x C222)	Y	Y	N	OB NVMe	1

### Details of storage configs - Compute Complex Neptune Core

The following table lists the detailed storage configurations for servers with the Lenovo Compute Complex Neptune Core open-loop water cooling. Drive configurations include 2.5-inch and E3.S front drives bays.

Go back to the [overview of the configurations](#).

Return to [Storage configurations](#).

The table also includes a **PCIe slots** column that indicates the number of slots available with each configuration. Mouse over the slot count to see the slot numbers. For details of the slots supported with each configuration, refer to the [Slot configurations](#) section.

Table 31. Details of storage configs - Compute Complex Neptune Core

Config	CPUs	CPU cooling			Front drive bays				Mid drives		Rear drives			Backplanes	M.2			Controllers	PCIe slots ?		
		Air cooled	Open loop CPUs	Open loop CPUs+Mem	SAS/SATA	AnyBay	NVMe	E3.S 1T	E3.S 2T	2.5" SAS/SATA	2.5" NVMe	3.5" SAS/SATA	2.5" SAS/SATA		2.5" NVMe	2.5" AnyBay	M.2 Internal			M.2 Rear HS	M.2 Front HS
87-1	2 only	N	N	Y	0	0	8	0	0	0	0	0	0	0	0	8x2.5" NVMe G5 (C46P)	Y	Y	Y	OB NVMe	5
88-1	2 only	N	N	Y	0	8	0	0	0	0	0	0	0	0	0	8x2.5" AnyBay G5 (C3RU)	Y	Y	Y	OB NVMe + (5350-8i or 9350-8i or 4350-16i or 9350-16i)	5
88-2	2 only	N	N	Y													Y	Y	Y	OB NVMe + (545-8i or 940-8i or 440-16i or 940-16i)	5
88-3	2 only	N	N	Y													Y	Y	Y	OB NVMe + (440-16i CFF or 940-16i CFF)	4
89-1	2 only	N	N	Y	0	0	16	0	0	0	0	0	0	0	0	2x 8x2.5" NVMe G5 (2x C46P)	Y	Y	Y	OB NVMe	3
90-1	2 only	N	N	Y	0	8	8	0	0	0	0	0	0	0	0	8x2.5" AnyBay G5 (C3RU) + 8x2.5" NVMe G5 (C46P)	Y	Y	Y	OB NVMe + (5350-8i or 9350-8i or 4350-16i or 9350-16i)	3

Config	CPUs	CPU cooling			Front drive bays				Mid drives		Rear drives				Backplanes	M.2			PCle slots ?		
		Air cooled	Open loop CPUs	Open loop CPUs+Mem	SAS/SATA	AnyBay	NVMe	E3.S 1T	E3.S 2T	2.5" SAS/SATA	2.5" NVMe	3.5" SAS/SATA	2.5" SAS/SATA	2.5" NVMe		2.5" AnyBay	M.2 Internal	M.2 Rear HS		M.2 Front HS	Controllers
90-2	2 only	N	N	Y												Y	Y	Y	OB NVMe + (545-8i or 940-8i or 440-16i or 940-16i)	3	
90-3	2 only	N	N	Y												Y	Y	Y	OB NVMe + (440-16i CFF or 940-16i CFF)	2	
91-1	2 only	N	N	Y	8	8	0	0	0	0	0	0	0	0	0	8x2.5" SAS/SATA (C3RT) + 8x2.5" AnyBay G5 (C3RU)	Y	Y	Y	OB NVMe + 2x (5350-8i or 9350-8i)	5
91-2	2 only	N	N	Y													Y	Y	Y	OB NVMe + 2x (545-8i or 940-8i)	5
91-3	2 only	N	N	Y													Y	Y	Y	OB NVMe + (4350-16i or 9350-16i)	5
91-4	2 only	N	N	Y													Y	Y	Y	OB NVMe + (440-16i or 940-16i)	5
91-5	2 only	N	N	Y													Y	Y	Y	OB NVMe + (440-16i CFF or 940-16i CFF)	4
92-1	2 only	N	N	Y	8	0	8	0	0	0	0	0	0	0	0	8x2.5" SAS/SATA (C3RT) + 8x2.5" NVMe G5 (C46P)	Y	Y	Y	OB NVMe + (5350-8i or 9350-8i or 4350-16i or 9350-16i)	5
92-2	2 only	N	N	Y													Y	Y	Y	OB NVMe + (545-8i or 940-8i or 440-16i or 940-16i)	5
92-3	2 only	N	N	Y													Y	Y	Y	OB NVMe + (440-16i CFF or 940-16i CFF)	4
97-1	2 only	N	N	Y	0	0	0	8	0	0	0	0	0	0	0	2x 4xE3.S 1T NVMe G5 (2x C221)	Y	Y	Y	OB NVMe	6
98-1	2 only	N	N	Y	0	0	0	16	0	0	0	0	0	0	0	4x 4xE3.S 1T NVMe G5 (4x C221)	Y	Y	Y	OB NVMe	4
103-1	2 only	N	N	Y	8	0	0	0	0	0	0	0	0	0	0	8x2.5" SAS/SATA (C3RT)	Y	Y	Y	(5350-8i or 9350-8i or 4350-16i or 9350-16i)	8
103-2	2 only	N	N	Y													Y	Y	Y	(545-8i or 940-8i or 440-16i or 940-16i)	8
103-3	2 only	N	N	Y													Y	Y	Y	(440-16i CFF or 940-16i CFF)	7
104-1	2 only	N	N	Y	0	8	0	0	0	0	0	0	0	0	0	8x2.5" AnyBay G5 (C3RU) (Tri-mode)	Y	Y	Y	(940-8i or 940-16i) Tri-mode	8
104-2	2 only	N	N	Y													Y	Y	Y	940-16i CFF Tri-mode	7
105-1	2 only	N	N	Y	16	0	0	0	0	0	0	0	0	0	0	2x 8x2.5" SAS/SATA (2x C3RT)	Y	Y	Y	2x (5350-8i or 9350-8i)	8
105-2	2 only	N	N	Y													Y	Y	Y	2x (545-8i or 940-8i)	8

Config	CPUs	CPU cooling			Front drive bays	Mid drives	Rear drives	Backplanes	M.2			Controllers	PCIe slots ?							
		Air cooled	Open loop CPUs	Open loop CPUs+Mem					SAS/SATA	AnyBay	NVMe			E3.S 1T	E3.S 2T	2.5" SAS/SATA	2.5" NVMe	3.5" SAS/SATA	2.5" SAS/SATA	2.5" NVMe
105-3	2 only	N	N	Y											Y	Y	Y	(4350-16i or 9350-16i)	8	
105-4	2 only	N	N	Y											Y	Y	Y	(440-16i or 940-16i)	8	
105-5	2 only	N	N	Y											Y	Y	Y	(440-16i CFF or 940-16i CFF)	7	
106-1	2 only	N	N	Y	0	16	0	0	0	0	0	0	0	0	2x 8x2.5" AnyBay G5 (2x C3RU) (Tri-mode)	Y	Y	Y	2x 940-8i Tri-mode	8
106-2	2 only	N	N	Y											Y	Y	Y	940-16i Tri-mode	8	
106-3	2 only	N	N	Y											Y	Y	Y	940-16i CFF Tri-mode	7	

## Field upgrades

The SR650 V4 is orderable without drive bays, allowing you to add a backplane, cabling and controllers as field upgrades. The server also supports upgrading some configurations by adding additional front drive bays (for example, upgrading from 8 to 16x 2.5-inch drive bays).

**Upgrade path:** The key criteria for upgrade support is to ensure that the target configuration is one of the supported drive bay configurations as listed in the [Supported drive bay combinations](#) section.

To add drive bays you will need to order both drive backplanes and cable kits. Backplane kits do not include cables.

In this section:

- [Drive bay field upgrades - 3.5-inch chassis](#)
- [Drive bay field upgrades - 2.5-inch chassis](#)
- [Drive bay field upgrades - E3.S chassis](#)
- [Drive bay field upgrades - Compute Complex Neptune water cooling](#)
- [Adding an Internal \(CFF\) RAID adapter or HBA](#)
- [Adding an Internal SAS Expander](#)
- [Replacement cable routing walls](#)
- [RAID flash power module \(supercap\) support](#)
- [2.5-inch drive bay fillers](#)

When adding drive bays, you will also need to add the appropriate storage controller(s). Consult the tables in the [Storage configurations](#) section to determine what controller sections are supported and what additional controllers you will need. Controllers are described in the [Controllers for internal storage](#) section.

### Drive bay field upgrades - 3.5-inch chassis

The table below lists the backplane kits and cable kits needed to build one of the supported 3.5-inch chassis configurations.

The Config numbers listed here match the configuration listed in the Storage configuration [Overview](#) and [Details](#) sections.

Return to [Field upgrades](#).

For more information about the backplane kits and cable kits, see the Lenovo server options site: [https://serveroption.lenovo.com/cable\\_kit\\_options/](https://serveroption.lenovo.com/cable_kit_options/)

**Tip:** The configurations listed in the table below are not in numerical order.

Table 32. Drive bay field upgrade for the 3.5-inch chassis (Blue = SAS/SATA, Purple = AnyBay, Red = NVMe)

Config	3.5" front bays			Mid bays		Rear bays				Backplane and cable kits required (all required)
	SAS/SATA	Any Bay	NVMe	2.5" SAS	2.5" NVMe	3.5" SAS	2.5" SAS	2.5" NVMe	2.5" Any	
117	8	0	0	0	0	0	0	0	0	<ul style="list-style-type: none"> <li>4XH7B03852, ThinkSystem SR650 V4 8x3.5" SAS/SATA Backplane Option Kit</li> <li>4X97B03862, ThinkSystem SR650 V4 3.5" Chassis Front Backplane SAS/SATA Cable Kit</li> </ul>
35	12	0	0	0	0	0	0	0	0	<ul style="list-style-type: none"> <li>4XH7B03851, ThinkSystem SR650 V4 12x3.5" SAS/SATA Backplane Option Kit</li> <li>4X97B03862, ThinkSystem SR650 V4 3.5" Chassis Front Backplane SAS/SATA Cable Kit</li> </ul>
36	8	4	0	0	0	0	0	0	0	<ul style="list-style-type: none"> <li>4XH7B03849, ThinkSystem SR650 V4 8x3.5" SAS/SATA + 4 AnyBay Backplane Option Kit</li> <li>4X97B03862, ThinkSystem SR650 V4 3.5" Chassis Front Backplane SAS/SATA Cable Kit</li> <li>4X97B03864, ThinkSystem SR650 V4 4x3.5" Chassis Front Backplane NVMe Cable Kit</li> </ul>
37	8	0	4	0	0	0	0	0	0	<ul style="list-style-type: none"> <li>4XH7B03850, ThinkSystem SR650 V4 8x3.5" SAS/SATA + 4 NVMe Backplane Option Kit</li> <li>4X97B03862, ThinkSystem SR650 V4 3.5" Chassis Front Backplane SAS/SATA Cable Kit</li> <li>4X97B03864, ThinkSystem SR650 V4 4x3.5" Chassis Front Backplane NVMe Cable Kit</li> </ul>
38	12	0	0	0	0	4	0	0	0	<ul style="list-style-type: none"> <li>4XH7B03851, ThinkSystem SR650 V4 12x3.5" SAS/SATA Backplane Option Kit</li> <li>4XH7B03853, ThinkSystem SR650 V4 4x3.5" SAS/SATA Rear Backplane Option Kit</li> <li>4X97B03862, ThinkSystem SR650 V4 3.5" Chassis Front Backplane SAS/SATA Cable Kit</li> <li>4X97B03865, ThinkSystem SR650 V4 3.5" Chassis Rear Backplane SAS/SATA Cable Kit</li> </ul>
41	12	0	0	0	0	0	0	0	4	<ul style="list-style-type: none"> <li>4XH7B03851, ThinkSystem SR650 V4 12x3.5" SAS/SATA Backplane Option Kit</li> <li>4XH7B03845, ThinkSystem SR650 V4 4x2.5" Anybay Rear Backplane option Kit</li> <li>4X97B03862, ThinkSystem SR650 V4 3.5" Chassis Front Backplane SAS/SATA Cable Kit</li> <li>4X97B03873, ThinkSystem SR650 V4 2.5" Chassis Rear SAS/SATA Cable Kit</li> <li>4XH7B03846, ThinkSystem SR650 V4 4x2.5" NVMe Rear Backplane option Kit</li> </ul>
118	12	0	0	0	0	0	0	4	0	<ul style="list-style-type: none"> <li>4XH7B03851, ThinkSystem SR650 V4 12x3.5" SAS/SATA Backplane Option Kit</li> <li>4XH7B03846, ThinkSystem SR650 V4 4x2.5" NVMe Rear Backplane option Kit</li> <li>4X97B03862, ThinkSystem SR650 V4 3.5" Chassis Front Backplane SAS/SATA Cable Kit</li> <li>4X97B03873, ThinkSystem SR650 V4 2.5" Chassis Rear SAS/SATA Cable Kit</li> <li>4XH7B03846, ThinkSystem SR650 V4 4x2.5" NVMe Rear Backplane option Kit</li> </ul>
42	12	0	0	0	8	0	0	0	0	<ul style="list-style-type: none"> <li>4XH7B03851, ThinkSystem SR650 V4 12x3.5" SAS/SATA Backplane Option Kit</li> <li>4XH7B03843, ThinkSystem SR650 V4 8x2.5" NVMe Middle Backplane option Kit</li> <li>4X97B03862, ThinkSystem SR650 V4 3.5" Chassis Front Backplane SAS/SATA Cable Kit</li> <li>4XH7B03843, ThinkSystem SR650 V4 8x2.5" NVMe Middle Backplane option Kit</li> </ul>

Config	3.5" front bays			Mid bays		Rear bays				Backplane and cable kits required (all required)
	SAS/SATA	Any Bay	NVMe	2.5" SAS	2.5" NVMe	3.5" SAS	2.5" SAS	2.5" NVMe	2.5" Any	
122	8	4	0	0	0	0	0	4	0	<ul style="list-style-type: none"> <li>• <b>4XH7B03849</b>, ThinkSystem SR650 V4 8x3.5" SAS/SATA + 4 AnyBay Backplane Option Kit</li> <li>• <b>4XH7B03846</b>, ThinkSystem SR650 V4 4x2.5" NVMe Rear Backplane option Kit</li> <li>• <b>4X97B03862</b>, ThinkSystem SR650 V4 3.5" Chassis Front Backplane SAS/SATA Cable Kit</li> <li>• <b>4X97B03864</b>, ThinkSystem SR650 V4 4x3.5" Chassis Front Backplane NVMe Cable Kit</li> <li>• <b>4XH7B03846</b>, ThinkSystem SR650 V4 4x2.5" NVMe Rear Backplane option Kit</li> </ul>

### Drive bay field upgrades - 2.5-inch chassis

The tables below lists the backplane kits and cable kits needed to build one of the supported 2.5-inch chassis configurations.

The Config numbers listed here match the configuration listed in the Storage configuration [Overview](#) and [Details](#) sections.

Return to [Field upgrades](#).

**Note:** Front drive cable kits are based on the location of the backplane in the server. The three backplane locations are BP1, BP2 and BP3 as shown in the following figure.



Figure 18. Backplane numbering

For more information about the backplane kits and cable kits, see the Lenovo server options site: [https://serveroption.lenovo.com/cable\\_kit\\_options/](https://serveroption.lenovo.com/cable_kit_options/)

**Tip:** The configurations listed in the table below are not in numerical order.

Table 33. Drive bay field upgrade for the 2.5-inch chassis (Blue = SAS/SATA, Purple = AnyBay, Red = NVMe)

Config	2.5" front bays				Mid bays		Rear bays				Backplane and cable kits required (all required)
	SAS/SATA	Any Bay	NVMe	Tri-Mode	2.5" SAS	2.5" NVMe	3.5" SAS	2.5" SAS	2.5" NVMe	2.5" Any	
1	8	0	0	0	0	0	0	0	0	0	<ul style="list-style-type: none"> <li>• <b>4XH7B03842</b>, ThinkSystem SR650/a V4 8x2.5" SAS/SATA Backplane Option Kit</li> <li>• <b>4X97B04117</b>, ThinkSystem SR650/a V4 2.5" Chassis Front BP1 SAS/SATA Cable Kit</li> </ul>
2	0	0	8	0	0	0	0	0	0	0	<ul style="list-style-type: none"> <li>• <b>4XH7B03841</b>, ThinkSystem SR650/a V4 8x2.5" NVMe Gen5 Backplane Option Kit</li> <li>• <b>4X97B03867</b>, ThinkSystem SR650 V4 2.5" Chassis Front BP1 NVMe Cable Kit</li> </ul>
3	0	8	0	0	0	0	0	0	0	0	<ul style="list-style-type: none"> <li>• <b>4XH7B03840</b>, ThinkSystem SR650/a V4 8x2.5" AnyBay Gen5 Backplane Option Kit</li> <li>• <b>4X97B04117</b>, ThinkSystem SR650/a V4 2.5" Chassis Front BP1 SAS/SATA Cable Kit</li> <li>• <b>4X97B03867</b>, ThinkSystem SR650 V4 2.5" Chassis Front BP1 NVMe Cable Kit</li> </ul>

Config	2.5" front bays				Mid bays		Rear bays				Backplane and cable kits required (all required)
	SAS/SATA	Any Bay	NVMe	Tri-Mode	2.5" SAS	2.5" NVMe	3.5" SAS	2.5" SAS	2.5" NVMe	2.5" Any	
5	0	0	0	8	0	0	0	0	0	0	<ul style="list-style-type: none"> <li>• <b>4XH7B03840</b>, ThinkSystem SR650/a V4 8x2.5" AnyBay Gen5 Backplane Option Kit</li> <li>• <b>4X97B04117</b>, ThinkSystem SR650/a V4 2.5" Chassis Front BP1 SAS/SATA Cable Kit</li> </ul>
6	16	0	0	0	0	0	0	0	0	0	<ul style="list-style-type: none"> <li>• <b>4XH7B03842</b>, ThinkSystem SR650/a V4 8x2.5" SAS/SATA Backplane Option Kit</li> <li>• <b>4XH7B03842</b>, ThinkSystem SR650/a V4 8x2.5" SAS/SATA Backplane Option Kit</li> <li>• <b>4X97B04117</b>, ThinkSystem SR650/a V4 2.5" Chassis Front BP1 SAS/SATA Cable Kit</li> <li>• <b>4X97B03870</b>, ThinkSystem SR650 V4 2.5" Chassis Front BP2 SAS/SATA Cable Kit</li> </ul>
7	0	0	16	0	0	0	0	0	0	0	<ul style="list-style-type: none"> <li>• <b>4XH7B03841</b>, ThinkSystem SR650/a V4 8x2.5" NVMe Gen5 Backplane Option Kit</li> <li>• <b>4XH7B03841</b>, ThinkSystem SR650/a V4 8x2.5" NVMe Gen5 Backplane Option Kit</li> <li>• <b>4X97B03867</b>, ThinkSystem SR650 V4 2.5" Chassis Front BP1 NVMe Cable Kit</li> <li>• <b>4X97B03869</b>, ThinkSystem SR650 V4 2.5" Chassis Front BP2 NVMe Cable Kit</li> </ul>
11	0	0	0	16	0	0	0	0	0	0	<ul style="list-style-type: none"> <li>• <b>4XH7B03840</b>, ThinkSystem SR650/a V4 8x2.5" AnyBay Gen5 Backplane Option Kit</li> <li>• <b>4XH7B03840</b>, ThinkSystem SR650/a V4 8x2.5" AnyBay Gen5 Backplane Option Kit</li> <li>• <b>4X97B04117</b>, ThinkSystem SR650/a V4 2.5" Chassis Front BP1 SAS/SATA Cable Kit</li> <li>• <b>4X97B03870</b>, ThinkSystem SR650 V4 2.5" Chassis Front BP2 SAS/SATA Cable Kit</li> </ul>
8	0	8	8	0	0	0	0	0	0	0	<ul style="list-style-type: none"> <li>• <b>4XH7B03840</b>, ThinkSystem SR650/a V4 8x2.5" AnyBay Gen5 Backplane Option Kit</li> <li>• <b>4XH7B03841</b>, ThinkSystem SR650/a V4 8x2.5" NVMe Gen5 Backplane Option Kit</li> <li>• <b>4X97B04117</b>, ThinkSystem SR650/a V4 2.5" Chassis Front BP1 SAS/SATA Cable Kit</li> <li>• <b>4X97B03867</b>, ThinkSystem SR650 V4 2.5" Chassis Front BP1 NVMe Cable Kit</li> <li>• <b>4X97B03869</b>, ThinkSystem SR650 V4 2.5" Chassis Front BP2 NVMe Cable Kit</li> </ul>
9	8	8	0	0	0	0	0	0	0	0	<ul style="list-style-type: none"> <li>• <b>4XH7B03842</b>, ThinkSystem SR650/a V4 8x2.5" SAS/SATA Backplane Option Kit</li> <li>• <b>4XH7B03840</b>, ThinkSystem SR650/a V4 8x2.5" AnyBay Gen5 Backplane Option Kit</li> <li>• <b>4X97B04117</b>, ThinkSystem SR650/a V4 2.5" Chassis Front BP1 SAS/SATA Cable Kit</li> <li>• <b>4X97B03870</b>, ThinkSystem SR650 V4 2.5" Chassis Front BP2 SAS/SATA Cable Kit</li> <li>• <b>4X97B03869</b>, ThinkSystem SR650 V4 2.5" Chassis Front BP2 NVMe Cable Kit</li> </ul>
10	8	0	8	0	0	0	0	0	0	0	<ul style="list-style-type: none"> <li>• <b>4XH7B03842</b>, ThinkSystem SR650/a V4 8x2.5" SAS/SATA Backplane Option Kit</li> <li>• <b>4XH7B03841</b>, ThinkSystem SR650/a V4 8x2.5" NVMe Gen5 Backplane Option Kit</li> <li>• <b>4X97B04117</b>, ThinkSystem SR650/a V4 2.5" Chassis Front BP1 SAS/SATA Cable Kit</li> <li>• <b>4X97B03869</b>, ThinkSystem SR650 V4 2.5" Chassis Front BP2 NVMe Cable Kit</li> </ul>

Config	2.5" front bays				Mid bays		Rear bays				Backplane and cable kits required (all required)
	SAS/SATA	Any Bay	NVMe	Tri-Mode	2.5" SAS	2.5" NVMe	3.5" SAS	2.5" SAS	2.5" NVMe	2.5" Any	
12	24	0	0	0	0	0	0	0	0	0	<ul style="list-style-type: none"> <li>• <b>4XH7B03842</b>, ThinkSystem SR650/a V4 8x2.5" SAS/SATA Backplane Option Kit</li> <li>• <b>4XH7B03842</b>, ThinkSystem SR650/a V4 8x2.5" SAS/SATA Backplane Option Kit</li> <li>• <b>4XH7B03842</b>, ThinkSystem SR650/a V4 8x2.5" SAS/SATA Backplane Option Kit</li> <li>• <b>4X97B04117</b>, ThinkSystem SR650/a V4 2.5" Chassis Front BP1 SAS/SATA Cable Kit</li> <li>• <b>4X97B03870</b>, ThinkSystem SR650 V4 2.5" Chassis Front BP2 SAS/SATA Cable Kit</li> <li>• <b>4X97B03872</b>, ThinkSystem SR650 V4 2.5" Chassis Front BP3 SAS/SATA Cable Kit</li> </ul>
13	0	0	24	0	0	0	0	0	0	0	<ul style="list-style-type: none"> <li>• <b>4XH7B03841</b>, ThinkSystem SR650/a V4 8x2.5" NVMe Gen5 Backplane Option Kit</li> <li>• <b>4XH7B03841</b>, ThinkSystem SR650/a V4 8x2.5" NVMe Gen5 Backplane Option Kit</li> <li>• <b>4XH7B03841</b>, ThinkSystem SR650/a V4 8x2.5" NVMe Gen5 Backplane Option Kit</li> <li>• <b>4X97B03880</b>, ThinkSystem SR650 V4 2.5" Chassis 24 NVMe Gen5 Cable Kit</li> </ul>
14	16	8	0	0	0	0	0	0	0	0	<ul style="list-style-type: none"> <li>• <b>4XH7B03842</b>, ThinkSystem SR650/a V4 8x2.5" SAS/SATA Backplane Option Kit</li> <li>• <b>4XH7B03842</b>, ThinkSystem SR650/a V4 8x2.5" SAS/SATA Backplane Option Kit</li> <li>• <b>4XH7B03840</b>, ThinkSystem SR650/a V4 8x2.5" AnyBay Gen5 Backplane Option Kit</li> <li>• <b>4X97B04117</b>, ThinkSystem SR650/a V4 2.5" Chassis Front BP1 SAS/SATA Cable Kit</li> <li>• <b>4X97B03870</b>, ThinkSystem SR650 V4 2.5" Chassis Front BP2 SAS/SATA Cable Kit</li> <li>• <b>4X97B03872</b>, ThinkSystem SR650 V4 2.5" Chassis Front BP3 SAS/SATA Cable Kit</li> <li>• <b>4X97B03871</b>, ThinkSystem SR650 V4 2.5" Chassis Front BP3 NVMe Cable Kit</li> </ul>
15	16	0	8	0	0	0	0	0	0	0	<ul style="list-style-type: none"> <li>• <b>4XH7B03842</b>, ThinkSystem SR650/a V4 8x2.5" SAS/SATA Backplane Option Kit</li> <li>• <b>4XH7B03842</b>, ThinkSystem SR650/a V4 8x2.5" SAS/SATA Backplane Option Kit</li> <li>• <b>4XH7B03841</b>, ThinkSystem SR650/a V4 8x2.5" NVMe Gen5 Backplane Option Kit</li> <li>• <b>4X97B04117</b>, ThinkSystem SR650/a V4 2.5" Chassis Front BP1 SAS/SATA Cable Kit</li> <li>• <b>4X97B03870</b>, ThinkSystem SR650 V4 2.5" Chassis Front BP2 SAS/SATA Cable Kit</li> <li>• <b>4X97B03871</b>, ThinkSystem SR650 V4 2.5" Chassis Front BP3 NVMe Cable Kit</li> </ul>
16	0	0	0	24	0	0	0	0	0	0	<ul style="list-style-type: none"> <li>• <b>4XH7B03840</b>, ThinkSystem SR650/a V4 8x2.5" AnyBay Gen5 Backplane Option Kit</li> <li>• <b>4XH7B03840</b>, ThinkSystem SR650/a V4 8x2.5" AnyBay Gen5 Backplane Option Kit</li> <li>• <b>4XH7B03840</b>, ThinkSystem SR650/a V4 8x2.5" AnyBay Gen5 Backplane Option Kit</li> <li>• <b>4X97B04117</b>, ThinkSystem SR650/a V4 2.5" Chassis Front BP1 SAS/SATA Cable Kit</li> <li>• <b>4X97B03870</b>, ThinkSystem SR650 V4 2.5" Chassis Front BP2 SAS/SATA Cable Kit</li> <li>• <b>4X97B03872</b>, ThinkSystem SR650 V4 2.5" Chassis Front BP3 SAS/SATA Cable Kit</li> </ul>

Config	2.5" front bays				Mid bays		Rear bays				Backplane and cable kits required (all required)
	SAS/SATA	Any Bay	NVMe	Tri-Mode	2.5" SAS	2.5" NVMe	3.5" SAS	2.5" SAS	2.5" NVMe	2.5" Any	
17	24	0	0	0	0	0	0	4	0	0	<ul style="list-style-type: none"> <li>• <b>4XH7B03842</b>, ThinkSystem SR650/a V4 8x2.5" SAS/SATA Backplane Option Kit</li> <li>• <b>4XH7B03842</b>, ThinkSystem SR650/a V4 8x2.5" SAS/SATA Backplane Option Kit</li> <li>• <b>4XH7B03842</b>, ThinkSystem SR650/a V4 8x2.5" SAS/SATA Backplane Option Kit</li> <li>• <b>4XH7B03847</b>, ThinkSystem SR650 V4 4x2.5" SAS/SATA Rear Backplane option Kit</li> <li>• <b>4X97B04117</b>, ThinkSystem SR650/a V4 2.5" Chassis Front BP1 SAS/SATA Cable Kit</li> <li>• <b>4X97B03870</b>, ThinkSystem SR650 V4 2.5" Chassis Front BP2 SAS/SATA Cable Kit</li> <li>• <b>4X97B03872</b>, ThinkSystem SR650 V4 2.5" Chassis Front BP3 SAS/SATA Cable Kit</li> <li>• <b>4X97B03873</b>, ThinkSystem SR650 V4 2.5" Chassis Rear SAS/SATA Cable Kit</li> </ul>
18	24	0	0	0	0	0	0	0	0	4	<ul style="list-style-type: none"> <li>• <b>4XH7B03842</b>, ThinkSystem SR650/a V4 8x2.5" SAS/SATA Backplane Option Kit</li> <li>• <b>4XH7B03842</b>, ThinkSystem SR650/a V4 8x2.5" SAS/SATA Backplane Option Kit</li> <li>• <b>4XH7B03842</b>, ThinkSystem SR650/a V4 8x2.5" SAS/SATA Backplane Option Kit</li> <li>• <b>4XH7B03847</b>, ThinkSystem SR650 V4 4x2.5" SAS/SATA Rear Backplane option Kit</li> <li>• <b>4X97B04117</b>, ThinkSystem SR650/a V4 2.5" Chassis Front BP1 SAS/SATA Cable Kit</li> <li>• <b>4X97B03870</b>, ThinkSystem SR650 V4 2.5" Chassis Front BP2 SAS/SATA Cable Kit</li> <li>• <b>4X97B03872</b>, ThinkSystem SR650 V4 2.5" Chassis Front BP3 SAS/SATA Cable Kit</li> <li>• <b>4X97B03873</b>, ThinkSystem SR650 V4 2.5" Chassis Rear SAS/SATA Cable Kit</li> <li>• <b>4X97B03874</b>, ThinkSystem SR650 V4 2.5" Chassis Rear NVMe Cable Kit</li> </ul>
19	16	8	0	0	0	0	0	4	0	0	<ul style="list-style-type: none"> <li>• <b>4XH7B03842</b>, ThinkSystem SR650/a V4 8x2.5" SAS/SATA Backplane Option Kit</li> <li>• <b>4XH7B03842</b>, ThinkSystem SR650/a V4 8x2.5" SAS/SATA Backplane Option Kit</li> <li>• <b>4XH7B03840</b>, ThinkSystem SR650/a V4 8x2.5" AnyBay Gen5 Backplane Option Kit</li> <li>• <b>4XH7B03847</b>, ThinkSystem SR650 V4 4x2.5" SAS/SATA Rear Backplane option Kit</li> <li>• <b>4X97B04117</b>, ThinkSystem SR650/a V4 2.5" Chassis Front BP1 SAS/SATA Cable Kit</li> <li>• <b>4X97B03870</b>, ThinkSystem SR650 V4 2.5" Chassis Front BP2 SAS/SATA Cable Kit</li> <li>• <b>4X97B03872</b>, ThinkSystem SR650 V4 2.5" Chassis Front BP3 SAS/SATA Cable Kit</li> <li>• <b>4X97B03871</b>, ThinkSystem SR650 V4 2.5" Chassis Front BP3 NVMe Cable Kit</li> <li>• <b>4X97B03873</b>, ThinkSystem SR650 V4 2.5" Chassis Rear SAS/SATA Cable Kit</li> </ul>

Config	2.5" front bays				Mid bays		Rear bays				Backplane and cable kits required (all required)
	SAS/SATA	Any Bay	NVMe	Tri-Mode	2.5" SAS	2.5" NVMe	3.5" SAS	2.5" SAS	2.5" NVMe	2.5" Any	
20	24	0	0	0	8	0	0	0	0	0	<ul style="list-style-type: none"> <li>• <b>4XH7B03842</b>, ThinkSystem SR650/a V4 8x2.5" SAS/SATA Backplane Option Kit</li> <li>• <b>4XH7B03842</b>, ThinkSystem SR650/a V4 8x2.5" SAS/SATA Backplane Option Kit</li> <li>• <b>4XH7B03842</b>, ThinkSystem SR650/a V4 8x2.5" SAS/SATA Backplane Option Kit</li> <li>• <b>4XH7B03844</b>, ThinkSystem SR650 V4 8x2.5" SAS/SATA Middle Backplane option Kit</li> <li>• <b>4X97B04117</b>, ThinkSystem SR650/a V4 2.5" Chassis Front BP1 SAS/SATA Cable Kit</li> <li>• <b>4X97B03870</b>, ThinkSystem SR650 V4 2.5" Chassis Front BP2 SAS/SATA Cable Kit</li> <li>• <b>4X97B03872</b>, ThinkSystem SR650 V4 2.5" Chassis Front BP3 SAS/SATA Cable Kit</li> <li>• <b>4X97B03875</b>, ThinkSystem SR650 V4 2.5" Chassis Middle SAS/SATA Cable Kit</li> </ul>
21	16	8	0	0	8	0	0	0	0	0	<ul style="list-style-type: none"> <li>• <b>4XH7B03842</b>, ThinkSystem SR650/a V4 8x2.5" SAS/SATA Backplane Option Kit</li> <li>• <b>4XH7B03842</b>, ThinkSystem SR650/a V4 8x2.5" SAS/SATA Backplane Option Kit</li> <li>• <b>4XH7B03840</b>, ThinkSystem SR650/a V4 8x2.5" AnyBay Gen5 Backplane Option Kit</li> <li>• <b>4XH7B03844</b>, ThinkSystem SR650 V4 8x2.5" SAS/SATA Middle Backplane option Kit</li> <li>• <b>4X97B04117</b>, ThinkSystem SR650/a V4 2.5" Chassis Front BP1 SAS/SATA Cable Kit</li> <li>• <b>4X97B03870</b>, ThinkSystem SR650 V4 2.5" Chassis Front BP2 SAS/SATA Cable Kit</li> <li>• <b>4X97B03872</b>, ThinkSystem SR650 V4 2.5" Chassis Front BP3 SAS/SATA Cable Kit</li> <li>• <b>4X97B03871</b>, ThinkSystem SR650 V4 2.5" Chassis Front BP3 NVMe Cable Kit</li> <li>• <b>4X97B03875</b>, ThinkSystem SR650 V4 2.5" Chassis Middle SAS/SATA Cable Kit</li> </ul>
22	16	8	0	0	0	0	0	8	0	0	<ul style="list-style-type: none"> <li>• <b>4XH7B03842</b>, ThinkSystem SR650/a V4 8x2.5" SAS/SATA Backplane Option Kit</li> <li>• <b>4XH7B03842</b>, ThinkSystem SR650/a V4 8x2.5" SAS/SATA Backplane Option Kit</li> <li>• <b>4XH7B03840</b>, ThinkSystem SR650/a V4 8x2.5" AnyBay Gen5 Backplane Option Kit</li> <li>• <b>4XH7B03847</b>, ThinkSystem SR650 V4 4x2.5" SAS/SATA Rear Backplane option Kit</li> <li>• <b>4X97B04117</b>, ThinkSystem SR650/a V4 2.5" Chassis Front BP1 SAS/SATA Cable Kit</li> <li>• <b>4X97B03870</b>, ThinkSystem SR650 V4 2.5" Chassis Front BP2 SAS/SATA Cable Kit</li> <li>• <b>4X97B03872</b>, ThinkSystem SR650 V4 2.5" Chassis Front BP3 SAS/SATA Cable Kit</li> <li>• <b>4X97B03871</b>, ThinkSystem SR650 V4 2.5" Chassis Front BP3 NVMe Cable Kit</li> <li>• <b>4X97B03873</b>, ThinkSystem SR650 V4 2.5" Chassis Rear SAS/SATA Cable Kit</li> </ul>

Config	2.5" front bays				Mid bays		Rear bays				Backplane and cable kits required (all required)
	SAS/SATA	Any Bay	NVMe	Tri-Mode	2.5" SAS	2.5" NVMe	3.5" SAS	2.5" SAS	2.5" NVMe	2.5" Any	
23	24	0	0	0	0	0	0	8	0	0	<ul style="list-style-type: none"> <li>• <b>4XH7B03842</b>, ThinkSystem SR650/a V4 8x2.5" SAS/SATA Backplane Option Kit</li> <li>• <b>4XH7B03842</b>, ThinkSystem SR650/a V4 8x2.5" SAS/SATA Backplane Option Kit</li> <li>• <b>4XH7B03842</b>, ThinkSystem SR650/a V4 8x2.5" SAS/SATA Backplane Option Kit</li> <li>• <b>4XH7B03848</b>, ThinkSystem SR650 V4 8x2.5" SAS/SATA Rear Backplane option Kit</li> <li>• <b>4X97B04117</b>, ThinkSystem SR650/a V4 2.5" Chassis Front BP1 SAS/SATA Cable Kit</li> <li>• <b>4X97B03870</b>, ThinkSystem SR650 V4 2.5" Chassis Front BP2 SAS/SATA Cable Kit</li> <li>• <b>4X97B03872</b>, ThinkSystem SR650 V4 2.5" Chassis Front BP3 SAS/SATA Cable Kit</li> <li>• <b>4X97B03873</b>, ThinkSystem SR650 V4 2.5" Chassis Rear SAS/SATA Cable Kit</li> </ul>
101	0	0	24	0	0	0	0	0	4	0	<ul style="list-style-type: none"> <li>• <b>4XH7B03841</b>, ThinkSystem SR650/a V4 8x2.5" NVMe Gen5 Backplane Option Kit</li> <li>• <b>4XH7B03841</b>, ThinkSystem SR650/a V4 8x2.5" NVMe Gen5 Backplane Option Kit</li> <li>• <b>4XH7B03841</b>, ThinkSystem SR650/a V4 8x2.5" NVMe Gen5 Backplane Option Kit</li> <li>• <b>4XH7B03846</b>, ThinkSystem SR650 V4 4x2.5" NVMe Rear Backplane option Kit</li> <li>• <b>4X97B03881</b>, ThinkSystem SR650 V4 2.5" Chassis 28 NVMe Gen5 Cable Kit</li> </ul>
24	0	0	24	0	0	8	0	0	0	0	<ul style="list-style-type: none"> <li>• <b>4XH7B03841</b>, ThinkSystem SR650/a V4 8x2.5" NVMe Gen5 Backplane Option Kit</li> <li>• <b>4XH7B03841</b>, ThinkSystem SR650/a V4 8x2.5" NVMe Gen5 Backplane Option Kit</li> <li>• <b>4XH7B03841</b>, ThinkSystem SR650/a V4 8x2.5" NVMe Gen5 Backplane Option Kit</li> <li>• <b>4XH7B03843</b>, ThinkSystem SR650 V4 8x2.5" NVMe Middle Backplane option Kit</li> <li>• <b>4X97B03882</b>, ThinkSystem SR650 V4 2.5" Chassis 32 NVMe Gen5 Cable Kit</li> </ul>
25	0	0	24	0	0	8	0	0	4	0	<ul style="list-style-type: none"> <li>• <b>4XH7B03841</b>, ThinkSystem SR650/a V4 8x2.5" NVMe Gen5 Backplane Option Kit</li> <li>• <b>4XH7B03841</b>, ThinkSystem SR650/a V4 8x2.5" NVMe Gen5 Backplane Option Kit</li> <li>• <b>4XH7B03841</b>, ThinkSystem SR650/a V4 8x2.5" NVMe Gen5 Backplane Option Kit</li> <li>• <b>4XH7B03843</b>, ThinkSystem SR650 V4 8x2.5" NVMe Middle Backplane option Kit</li> <li>• <b>4XH7B03846</b>, ThinkSystem SR650 V4 4x2.5" NVMe Rear Backplane option Kit</li> <li>• <b>4X97B03883</b>, ThinkSystem SR650 V4 2.5" Chassis 36 NVMe Gen5 Cable Kit</li> </ul>

Config	2.5" front bays				Mid bays		Rear bays				Backplane and cable kits required (all required)
	SAS/SATA	Any Bay	NVMe	Tri-Mode	2.5" SAS	2.5" NVMe	3.5" SAS	2.5" SAS	2.5" NVMe	2.5" Any	
26	24	0	0	0	8	0	0	4	0	0	<ul style="list-style-type: none"> <li>• <b>4XH7B03842</b>, ThinkSystem SR650/a V4 8x2.5" SAS/SATA Backplane Option Kit</li> <li>• <b>4XH7B03842</b>, ThinkSystem SR650/a V4 8x2.5" SAS/SATA Backplane Option Kit</li> <li>• <b>4XH7B03842</b>, ThinkSystem SR650/a V4 8x2.5" SAS/SATA Backplane Option Kit</li> <li>• <b>4XH7B03844</b>, ThinkSystem SR650 V4 8x2.5" SAS/SATA Middle Backplane option Kit</li> <li>• <b>4XH7B03848</b>, ThinkSystem SR650 V4 8x2.5" SAS/SATA Rear Backplane option Kit</li> <li>• <b>4X97B04117</b>, ThinkSystem SR650/a V4 2.5" Chassis Front BP1 SAS/SATA Cable Kit</li> <li>• <b>4X97B03870</b>, ThinkSystem SR650 V4 2.5" Chassis Front BP2 SAS/SATA Cable Kit</li> <li>• <b>4X97B03872</b>, ThinkSystem SR650 V4 2.5" Chassis Front BP3 SAS/SATA Cable Kit</li> <li>• <b>4X97B03875</b>, ThinkSystem SR650 V4 2.5" Chassis Middle SAS/SATA Cable Kit</li> <li>• <b>4X97B03873</b>, ThinkSystem SR650 V4 2.5" Chassis Rear SAS/SATA Cable Kit</li> </ul>
27	24	0	0	0	8	0	0	8	0	0	<ul style="list-style-type: none"> <li>• <b>4XH7B03842</b>, ThinkSystem SR650/a V4 8x2.5" SAS/SATA Backplane Option Kit</li> <li>• <b>4XH7B03842</b>, ThinkSystem SR650/a V4 8x2.5" SAS/SATA Backplane Option Kit</li> <li>• <b>4XH7B03842</b>, ThinkSystem SR650/a V4 8x2.5" SAS/SATA Backplane Option Kit</li> <li>• <b>4XH7B03844</b>, ThinkSystem SR650 V4 8x2.5" SAS/SATA Middle Backplane option Kit</li> <li>• <b>4XH7B03847</b>, ThinkSystem SR650 V4 4x2.5" SAS/SATA Rear Backplane option Kit</li> <li>• <b>4X97B04117</b>, ThinkSystem SR650/a V4 2.5" Chassis Front BP1 SAS/SATA Cable Kit</li> <li>• <b>4X97B03870</b>, ThinkSystem SR650 V4 2.5" Chassis Front BP2 SAS/SATA Cable Kit</li> <li>• <b>4X97B03872</b>, ThinkSystem SR650 V4 2.5" Chassis Front BP3 SAS/SATA Cable Kit</li> <li>• <b>4X97B03875</b>, ThinkSystem SR650 V4 2.5" Chassis Middle SAS/SATA Cable Kit</li> <li>• <b>4X97B03873</b>, ThinkSystem SR650 V4 2.5" Chassis Rear SAS/SATA Cable Kit</li> </ul>
121	8	0	0	0	0	0	0	0	0	0	<ul style="list-style-type: none"> <li>• <b>4XH7B03842</b>, ThinkSystem SR650/a V4 8x2.5" SAS/SATA Backplane Option Kit</li> <li>• <b>4XH7B03841</b>, ThinkSystem SR650/a V4 8x2.5" NVMe Gen5 Backplane Option Kit</li> <li>• <b>4XH7B03841</b>, ThinkSystem SR650/a V4 8x2.5" NVMe Gen5 Backplane Option Kit</li> <li>• <b>4X97B04117</b>, ThinkSystem SR650/a V4 2.5" Chassis Front BP1 SAS/SATA Cable Kit</li> <li>• <b>4X97B03869</b>, ThinkSystem SR650 V4 2.5" Chassis Front BP2 NVMe Cable Kit</li> <li>• <b>4X97B03871</b>, ThinkSystem SR650 V4 2.5" Chassis Front BP3 NVMe Cable Kit</li> </ul>

### Drive bay field upgrades - E3.S chassis

The tables below lists the backplane kits and cable kits needed to build one of the supported configurations with E3.S drive bays.

The Config numbers listed here match the configuration listed in the Storage configuration [Overview](#) and [Details](#) sections.

Return to [Field upgrades](#).

**Note:** The table indicates the locations of each E3.S backplane. The locations of the 8 backplanes (BP1 to BP8) are shown in the following figure.



Figure 19. E3.S backplane numbering

For more information about the backplane kits and cable kits, see the Lenovo server options site: [https://serveroption.lenovo.com/cable\\_kit\\_options/](https://serveroption.lenovo.com/cable_kit_options/)

**Tip:** The configurations listed in the table below are not in numerical order.

Table 34. Field upgrades - E3.S drive bays (BP = Backplane)

Config (# of CPUs)	BP1	BP3	BP5	BP7	Backplane and cable kits required (all required) Some configs also require <a href="#">replacement cable walls</a>
	BP2	BP4	BP6	BP8	
59 (1P)			4x 1T	4x 1T	<ul style="list-style-type: none"> <li>2x 4XH7B03854, ThinkSystem V4 1U/2U E3.S 4x1T Backplane Option Kit</li> <li>2x 4X97B03884, ThinkSystem SR650 V4 E3.S 1T Short Cable Kit</li> </ul>
59 (2P)	4x 1T		4x 1T		<ul style="list-style-type: none"> <li>2x 4XH7B03854, ThinkSystem V4 1U/2U E3.S 4x1T Backplane Option Kit</li> <li>2x 4X97B03884, ThinkSystem SR650 V4 E3.S 1T Short Cable Kit</li> </ul>
60 (1P)			4x 1T	4x 1T	<ul style="list-style-type: none"> <li>2x 4XH7B03854, ThinkSystem V4 1U/2U E3.S 4x1T Backplane Option Kit</li> <li>2x 4XH7B03854, ThinkSystem V4 1U/2U E3.S 4x1T Backplane Option Kit</li> <li>2x 4X97B03884, ThinkSystem SR650 V4 E3.S 1T Short Cable Kit</li> <li>2x 4X97B03885, ThinkSystem SR650 V4 E3.S 1T Long Cable Kit</li> <li>1x 4X97B04305, ThinkSystem SR650/a V4 2U Cable Wall Option Kit</li> </ul>
60 (2P)	4x 1T	4x 1T	4x 1T	4x 1T	<ul style="list-style-type: none"> <li>4x 4XH7B03854, ThinkSystem V4 1U/2U E3.S 4x1T Backplane Option Kit</li> <li>4x 4X97B03884, ThinkSystem SR650 V4 E3.S 1T Short Cable Kit</li> <li>1x 4X97B04305, ThinkSystem SR650/a V4 2U Cable Wall Option Kit</li> </ul>
61 (2P)	4x 1T	4x 1T	4x 1T	4x 1T	<ul style="list-style-type: none"> <li>4x 4XH7B03854, ThinkSystem V4 1U/2U E3.S 4x1T Backplane Option Kit</li> <li>2x 4XH7B03854, ThinkSystem V4 1U/2U E3.S 4x1T Backplane Option Kit</li> <li>4x 4X97B03884, ThinkSystem SR650 V4 E3.S 1T Short Cable Kit</li> <li>2x 4X97B03885, ThinkSystem SR650 V4 E3.S 1T Long Cable Kit</li> </ul>
62 (2P)	4x 1T	4x 1T	4x 1T	4x 1T	<ul style="list-style-type: none"> <li>4x 4XH7B03854, ThinkSystem V4 1U/2U E3.S 4x1T Backplane Option Kit</li> <li>4x 4XH7B03854, ThinkSystem V4 1U/2U E3.S 4x1T Backplane Option Kit</li> <li>4x 4X97B03884, ThinkSystem SR650 V4 E3.S 1T Short Cable Kit</li> <li>4x 4X97B03885, ThinkSystem SR650 V4 E3.S 1T Long Cable Kit</li> <li>1x 4X97B04305, ThinkSystem SR650/a V4 2U Cable Wall Option Kit</li> </ul>
102 (1P)			2x 2T		<ul style="list-style-type: none"> <li>1x 4XH7B03856, ThinkSystem V4 1U/2U E3.S 2x2T Backplane Option Kit</li> <li>1x 4X97B03888, ThinkSystem SR650 V4 E3.S 2T Short Cable Kit</li> </ul>
63 (1P)			2x 2T	2x 2T	<ul style="list-style-type: none"> <li>2x 4XH7B03856, ThinkSystem V4 1U/2U E3.S 2x2T Backplane Option Kit</li> <li>2x 4X97B03888, ThinkSystem SR650 V4 E3.S 2T Short Cable Kit</li> </ul>
63 (2P)	2x 2T		2x 2T		<ul style="list-style-type: none"> <li>2x 4XH7B03856, ThinkSystem V4 1U/2U E3.S 2x2T Backplane Option Kit</li> <li>2x 4X97B03889, ThinkSystem SR650 V4 E3.S 2T Long Cable Kit</li> </ul>
64 (2P)	2x 2T	2x 2T	2x 2T	2x 2T	<ul style="list-style-type: none"> <li>4x 4XH7B03856, ThinkSystem V4 1U/2U E3.S 2x2T Backplane Option Kit</li> <li>4x 4X97B03888, ThinkSystem SR650 V4 E3.S 2T Short Cable Kit</li> </ul>
65 (2P)	2x 2T	2x 2T	2x 2T	2x 2T	<ul style="list-style-type: none"> <li>4x 4XH7B03856, ThinkSystem V4 1U/2U E3.S 2x2T Backplane Option Kit</li> <li>2x 4XH7B03856, ThinkSystem V4 1U/2U E3.S 2x2T Backplane Option Kit</li> <li>4x 4X97B03888, ThinkSystem SR650 V4 E3.S 2T Short Cable Kit</li> <li>2x 4X97B03889, ThinkSystem SR650 V4 E3.S 2T Long Cable Kit</li> </ul>
66 (1P)			4x 1T	2x 2T	<ul style="list-style-type: none"> <li>1x 4XH7B03854, ThinkSystem V4 1U/2U E3.S 4x1T Backplane Option Kit</li> <li>1x 4XH7B03856, ThinkSystem V4 1U/2U E3.S 2x2T Backplane Option Kit</li> <li>1x 4X97B03884, ThinkSystem SR650 V4 E3.S 1T Short Cable Kit</li> <li>1x 4X97B03888, ThinkSystem SR650 V4 E3.S 2T Short Cable Kit</li> </ul>

Config (# of CPUs)	BP1	BP3	BP5	BP7	Backplane and cable kits required (all required) Some configs also require <a href="#">replacement cable walls</a>
	BP2	BP4	BP6	BP8	
67 (1P)			4x 1T	4x 1T	<ul style="list-style-type: none"> <li>2x 4XH7B03854, ThinkSystem V4 1U/2U E3.S 4x1T Backplane Option Kit</li> <li>2x 4XH7B03856, ThinkSystem V4 1U/2U E3.S 2x2T Backplane Option Kit</li> <li>2x 4X97B03884, ThinkSystem SR650 V4 E3.S 1T Short Cable Kit</li> <li>2x 4X97B03889, ThinkSystem SR650 V4 E3.S 2T Long Cable Kit</li> <li>1x 4X97B04305, ThinkSystem SR650/a V4 2U Cable Wall Option Kit</li> </ul>
			2x 2T	2x 2T	
67 (2P)	4x 1T	4x 1T	2x 2T	2x 2T	<ul style="list-style-type: none"> <li>2x 4XH7B03854, ThinkSystem V4 1U/2U E3.S 4x1T Backplane Option Kit</li> <li>2x 4XH7B03856, ThinkSystem V4 1U/2U E3.S 2x2T Backplane Option Kit</li> <li>2x 4X97B03884, ThinkSystem SR650 V4 E3.S 1T Short Cable Kit</li> <li>2x 4X97B03888, ThinkSystem SR650 V4 E3.S 2T Short Cable Kit</li> </ul>
68 (2P)	4x 1T	2x 2T	4x 1T	2x 2T	<ul style="list-style-type: none"> <li>2x 4XH7B03854, ThinkSystem V4 1U/2U E3.S 4x1T Backplane Option Kit</li> <li>2x 4XH7B03856, ThinkSystem V4 1U/2U E3.S 2x2T Backplane Option Kit</li> <li>2x 4XH7B03885, ThinkSystem V4 1U/2U E3.S 2x2T Backplane Option Kit</li> <li>2x 4X97B03884, ThinkSystem SR650 V4 E3.S 1T Short Cable Kit</li> <li>2x 4X97B03888, ThinkSystem SR650 V4 E3.S 2T Short Cable Kit</li> <li>2x 4X97B03889, ThinkSystem SR650 V4 E3.S 2T Long Cable Kit</li> </ul>
	2x 2T		2x 2T		
69 (2P)	4x 1T	2x 2T	4x 1T	2x 2T	<ul style="list-style-type: none"> <li>2x 4XH7B03854, ThinkSystem V4 1U/2U E3.S 4x1T Backplane Option Kit</li> <li>2x 4XH7B03856, ThinkSystem V4 1U/2U E3.S 2x2T Backplane Option Kit</li> <li>4x 4XH7B03856, ThinkSystem V4 1U/2U E3.S 2x2T Backplane Option Kit</li> <li>2x 4X97B03884, ThinkSystem SR650 V4 E3.S 1T Short Cable Kit</li> <li>2x 4X97B03888, ThinkSystem SR650 V4 E3.S 2T Short Cable Kit</li> <li>4x 4X97B03889, ThinkSystem SR650 V4 E3.S 2T Long Cable Kit</li> <li>1x 4X97B04305, ThinkSystem SR650/a V4 2U Cable Wall Option Kit</li> </ul>
	2x 2T	2x 2T	2x 2T	2x 2T	
70 (2P)	4x 1T	4x 1T	4x 1T	4x 1T	<ul style="list-style-type: none"> <li>4x 4XH7B03854, ThinkSystem V4 1U/2U E3.S 4x1T Backplane Option Kit</li> <li>2x 4XH7B03856, ThinkSystem V4 1U/2U E3.S 2x2T Backplane Option Kit</li> <li>4x 4X97B03884, ThinkSystem SR650 V4 E3.S 1T Short Cable Kit</li> <li>2x 4X97B03889, ThinkSystem SR650 V4 E3.S 2T Long Cable Kit</li> </ul>
	2x 2T		2x 2T		
71 (2P)	4x 1T	4x 1T	4x 1T	4x 1T	<ul style="list-style-type: none"> <li>4x 4XH7B03854, ThinkSystem V4 1U/2U E3.S 4x1T Backplane Option Kit</li> <li>4x 4XH7B03856, ThinkSystem V4 1U/2U E3.S 2x2T Backplane Option Kit</li> <li>4x 4X97B03884, ThinkSystem SR650 V4 E3.S 1T Short Cable Kit</li> <li>4x 4X97B03889, ThinkSystem SR650 V4 E3.S 2T Long Cable Kit</li> <li>1x 4X97B04305, ThinkSystem SR650/a V4 2U Cable Wall Option Kit</li> </ul>
	2x 2T	2x 2T	2x 2T	2x 2T	
72 (2P)	4x 1T	4x 1T	4x 1T	4x 1T	<ul style="list-style-type: none"> <li>4x 4XH7B03854, ThinkSystem V4 1U/2U E3.S 4x1T Backplane Option Kit</li> <li>2x 4XH7B03854, ThinkSystem V4 1U/2U E3.S 4x1T Backplane Option Kit</li> <li>2x 4XH7B03856, ThinkSystem V4 1U/2U E3.S 2x2T Backplane Option Kit</li> <li>4x 4X97B03884, ThinkSystem SR650 V4 E3.S 1T Short Cable Kit</li> <li>2x 4X97B03885, ThinkSystem SR650 V4 E3.S 1T Long Cable Kit</li> <li>2x 4X97B03889, ThinkSystem SR650 V4 E3.S 2T Long Cable Kit</li> <li>1x 4X97B04305, ThinkSystem SR650/a V4 2U Cable Wall Option Kit</li> </ul>
	4x 1T	2x 2T	4x 1T	2x 2T	
119 (1P)			2x 2T	2x 2T	<ul style="list-style-type: none"> <li>2x 4XH7B03856, ThinkSystem V4 1U/2U E3.S 2x2T Backplane Option Kit</li> <li>1x 4XH7B03856, ThinkSystem V4 1U/2U E3.S 2x2T Backplane Option Kit</li> <li>2x 4X97B03888, ThinkSystem SR650 V4 E3.S 2T Short Cable Kit</li> <li>1x 4X97B03889, ThinkSystem SR650 V4 E3.S 2T Long Cable Kit</li> </ul>
			2x 2T		

### Drive bay field upgrades - Compute Complex Neptune water cooling

The tables below lists the backplane kits and cable kits needed to build one of the supported configurations using Lenovo Compute Complex Neptune water cooling.

The Config numbers listed here match the configuration listed in the Storage configuration [Overview](#) and [Details](#) sections.

Return to [Field upgrades](#).

For more information about the backplane kits and cable kits, see the Lenovo server options site: [https://serveroption.lenovo.com/cable\\_kit\\_options/](https://serveroption.lenovo.com/cable_kit_options/)

**Tip:** The configurations listed in the table below are not in numerical order.

Table 35. Drive bay field upgrade for the 2.5-inch chassis with Compute Complex Neptune water cooling (Blue = SAS/SATA, Purple = AnyBay, Red = NVMe)

Config	2.5" front bays				Mid bays		Rear bays				Backplane and cable kits required (all required)
	SAS/SATA	Any Bay	NVMe	Tri-Mode	2.5" SAS	2.5" NVMe	3.5" SAS	2.5" SAS	2.5" NVMe	2.5" Any	
103	8	0	0	0	0	0	0	0	0	0	<ul style="list-style-type: none"> <li>4XH7B03842, ThinkSystem SR650/a V4 8x2.5" SAS/SATA Backplane Option Kit</li> <li>4X97B04117, ThinkSystem SR650/a V4 2.5" Chassis Front BP1 SAS/SATA Cable Kit</li> </ul>
87	0	0	8	0	0	0	0	0	0	0	<ul style="list-style-type: none"> <li>4XH7B03841, ThinkSystem SR650/a V4 8x2.5" NVMe Gen5 Backplane Option Kit</li> <li>4X97B03867, ThinkSystem SR650 V4 2.5" Chassis Front BP1 NVMe Cable Kit</li> </ul>
88	0	8	0	0	0	0	0	0	0	0	<ul style="list-style-type: none"> <li>4XH7B03840, ThinkSystem SR650/a V4 8x2.5" AnyBay Gen5 Backplane Option Kit</li> <li>4X97B04117, ThinkSystem SR650/a V4 2.5" Chassis Front BP1 SAS/SATA Cable Kit</li> <li>4X97B03867, ThinkSystem SR650 V4 2.5" Chassis Front BP1 NVMe Cable Kit</li> </ul>
104	0	0	0	8	0	0	0	0	0	0	<ul style="list-style-type: none"> <li>4XH7B03840, ThinkSystem SR650/a V4 8x2.5" AnyBay Gen5 Backplane Option Kit</li> <li>4X97B04117, ThinkSystem SR650/a V4 2.5" Chassis Front BP1 SAS/SATA Cable Kit</li> </ul>
105	16	0	0	0	0	0	0	0	0	0	<ul style="list-style-type: none"> <li>4XH7B03842, ThinkSystem SR650/a V4 8x2.5" SAS/SATA Backplane Option Kit</li> <li>4XH7B03842, ThinkSystem SR650/a V4 8x2.5" SAS/SATA Backplane Option Kit</li> <li>4X97B04117, ThinkSystem SR650/a V4 2.5" Chassis Front BP1 SAS/SATA Cable Kit</li> <li>4X97B03870, ThinkSystem SR650 V4 2.5" Chassis Front BP2 SAS/SATA Cable Kit</li> </ul>
89	0	0	16	0	0	0	0	0	0	0	<ul style="list-style-type: none"> <li>4XH7B03841, ThinkSystem SR650/a V4 8x2.5" NVMe Gen5 Backplane Option Kit</li> <li>4XH7B03841, ThinkSystem SR650/a V4 8x2.5" NVMe Gen5 Backplane Option Kit</li> <li>4X97B03867, ThinkSystem SR650 V4 2.5" Chassis Front BP1 NVMe Cable Kit</li> <li>4X97B03869, ThinkSystem SR650 V4 2.5" Chassis Front BP2 NVMe Cable Kit</li> </ul>
106	0	0	0	16	0	0	0	0	0	0	<ul style="list-style-type: none"> <li>4XH7B03840, ThinkSystem SR650/a V4 8x2.5" AnyBay Gen5 Backplane Option Kit</li> <li>4XH7B03840, ThinkSystem SR650/a V4 8x2.5" AnyBay Gen5 Backplane Option Kit</li> <li>4X97B04117, ThinkSystem SR650/a V4 2.5" Chassis Front BP1 SAS/SATA Cable Kit</li> <li>4X97B03870, ThinkSystem SR650 V4 2.5" Chassis Front BP2 SAS/SATA Cable Kit</li> </ul>
90	0	8	8	0	0	0	0	0	0	0	<ul style="list-style-type: none"> <li>4XH7B03840, ThinkSystem SR650/a V4 8x2.5" AnyBay Gen5 Backplane Option Kit</li> <li>4XH7B03841, ThinkSystem SR650/a V4 8x2.5" NVMe Gen5 Backplane Option Kit</li> <li>4X97B04117, ThinkSystem SR650/a V4 2.5" Chassis Front BP1 SAS/SATA Cable Kit</li> <li>4X97B03867, ThinkSystem SR650 V4 2.5" Chassis Front BP1 NVMe Cable Kit</li> <li>4X97B03869, ThinkSystem SR650 V4 2.5" Chassis Front BP2 NVMe Cable Kit</li> </ul>

Config	2.5" front bays				Mid bays		Rear bays				Backplane and cable kits required (all required)
	SAS/SATA	Any Bay	NVMe	Tri-Mode	2.5" SAS	2.5" NVMe	3.5" SAS	2.5" SAS	2.5" NVMe	2.5" Any	
91	8	8	0	0	0	0	0	0	0	0	<ul style="list-style-type: none"> <li>• <b>4XH7B03842</b>, ThinkSystem SR650/a V4 8x2.5" SAS/SATA Backplane Option Kit</li> <li>• <b>4XH7B03840</b>, ThinkSystem SR650/a V4 8x2.5" AnyBay Gen5 Backplane Option Kit</li> <li>• <b>4X97B04117</b>, ThinkSystem SR650/a V4 2.5" Chassis Front BP1 SAS/SATA Cable Kit</li> <li>• <b>4X97B03870</b>, ThinkSystem SR650 V4 2.5" Chassis Front BP2 SAS/SATA Cable Kit</li> <li>• <b>4X97B03869</b>, ThinkSystem SR650 V4 2.5" Chassis Front BP2 NVMe Cable Kit</li> </ul>
92	8	0	8	0	0	0	0	0	0	0	<ul style="list-style-type: none"> <li>• <b>4XH7B03842</b>, ThinkSystem SR650/a V4 8x2.5" SAS/SATA Backplane Option Kit</li> <li>• <b>4XH7B03841</b>, ThinkSystem SR650/a V4 8x2.5" NVMe Gen5 Backplane Option Kit</li> <li>• <b>4X97B04117</b>, ThinkSystem SR650/a V4 2.5" Chassis Front BP1 SAS/SATA Cable Kit</li> <li>• <b>4X97B03869</b>, ThinkSystem SR650 V4 2.5" Chassis Front BP2 NVMe Cable Kit</li> </ul>

### Adding an Internal (CFF) RAID adapter or HBA

If you want to add an internal (CFF) storage adapter (HBA or RAID adapter) to a configuration, you will need to order the cable kit as listed in the following table. Suitable upgrades are either replacing an existing adapter in a rear PCIe slot, or adding the CFF adapter to a server without any storage adapter installed.

Table 36. Cable needed for field upgrades to add CFF adapter

Part number	Description
4X97B03877	ThinkSystem SR650/a V4 Internal Raid/HBA Adapter Cable Kit

### Adding an Internal SAS Expander

If you want to add an internal (CFF) SAS Expander adapter to a configuration, you will need to order the cable kit as listed in the following table.

Table 37. Cable needed for field upgrades to add SAS Expander

Part number	Description
4X97B03878	ThinkSystem SR650 V4 Internal Expander Adapter Cable Kit

## Replacement cable routing walls

Cable walls are used to guide signal and power cables through the server and to maximize airflow across the components. The server comes with 1U cable walls at both side of the processor board. It is recommended to replace the 1U cable walls with 2U cable walls when there are more than five cables routed at one side.

The 2U cable walls are required for some E3.S configurations and will be automatically derived for CTO orders. For field upgrades, see the [Drive bay field upgrades - E3.S chassis](#) section, where the table indicates when replacement cable walls are required.

Table 38. Replacement cable routing walls

Part number	Feature code	Description
4X97B04305	C3RS	ThinkSystem SR650/a V4 2U Cable Wall Option Kit <ul style="list-style-type: none"><li>• 2x 2U cable wall (SBB7A86017, C3RS)</li></ul>

For details on installing the cable wall replacements, see the SR650 V4 User Guide: [https://pubs.lenovo.com/sr650-v4/cable\\_wall\\_replacement\\_2u](https://pubs.lenovo.com/sr650-v4/cable_wall_replacement_2u)

## RAID flash power module (supercap) support

If you plan to add one of the RAID adapters that includes a RAID flash power module (supercap) as a field upgrade, then you will also need to order a Supercap installation kit for the power module. For CTO orders, the components in the installation kit are automatically derived when you select the RAID adapter.

The adapters that this applies to are as follows:

- Any supported RAID 940 adapter
- Any supported RAID 9350 adapter

There are up to four possible locations for supercaps, depending on the air baffle or mid-chassis drive bays installed, as follows:

- Standard air baffle: 4 supercaps
- GPU air baffle: 4 supercaps
- 2.5-inch mid-chassis drive bays: 2 supercaps

See the following User Guide page for the specifics on the locations: [https://pubs.lenovo.com/sr650-v4/supercap\\_replacement](https://pubs.lenovo.com/sr650-v4/supercap_replacement)

Supercap holders are integrated into the air baffles and mid-chassis drive cage. No additional components are needed.

## 2.5-inch drive bay fillers

Backplane option kits include the necessary drive bay fillers, however if needed, additional blanks can be ordered as listed in the following table.

Table 39. Drive bay fillers for 2.5-inch bays

Part number	Description
4XH7A99569	ThinkSystem 2.5" 1x1 HDD Filler by 8 units (contains 8x single drive-bay fillers)

## M.2 drives

In this section:

- [M.2 ordering information](#)
- [VROC RAID support for the B340i-2i adapter](#)
- [M.2 adapter features](#)
- [M.2 field upgrades for internal M.2](#)
- [M.2 field upgrades for hot-swap M.2](#)

The SR650 V4 supports one or two M.2 form-factor SATA or NVMe drives for use as an operating system boot solution or as additional storage.

M.2 drives can be installed in one of the following locations:

- Internal to the server (non-hot-swap) on an M.2 module which is mounted horizontally in the server. RAID is either integrated or with the use of VROC, depending on the M.2 adapter selected. Locations are as follows:
  - In servers without mid-chassis drives, the M.2 module is mounted on the air baffle
  - With a mid-chassis drive cage, the M.2 module is mounted on the drive cage, as shown in the [Mid drive bays](#) section.
- Rear-mounted hot-swap M.2 drives with integrated RAID.
- Front-mounted hot-swap M.2 drives with integrated RAID. Only supported with E3.S and 2.5-inch front drive configurations.

The following figure shows the SR650 V4 with front and rear hot-swap M.2 drive bays.

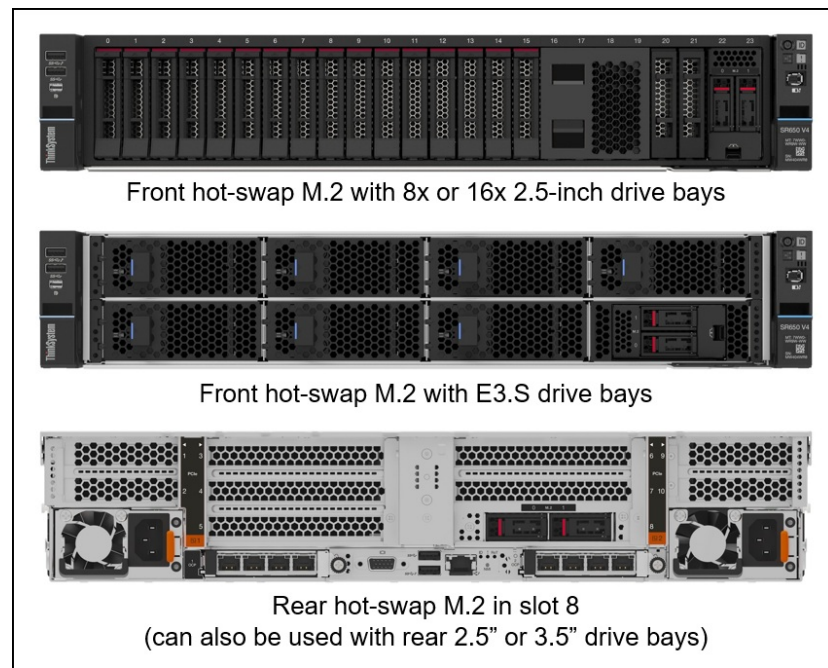

Figure 20. Hot-swap M.2 drive bays

The following figure shows the components of the rear hot-swap M.2 drive bays.

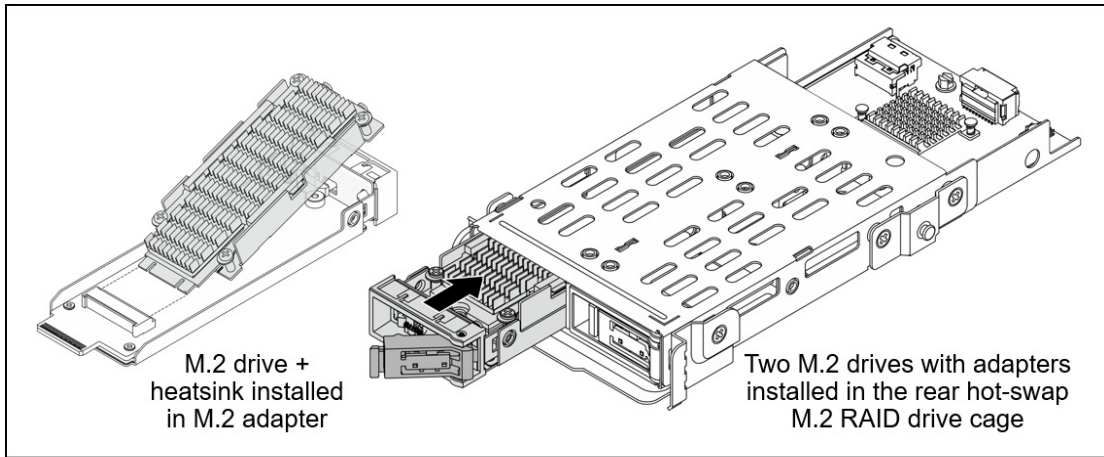

Figure 21. Rear hot-swap M.2 drive bays

The following figure shows the components of the front hot-swap M.2 drive bays.

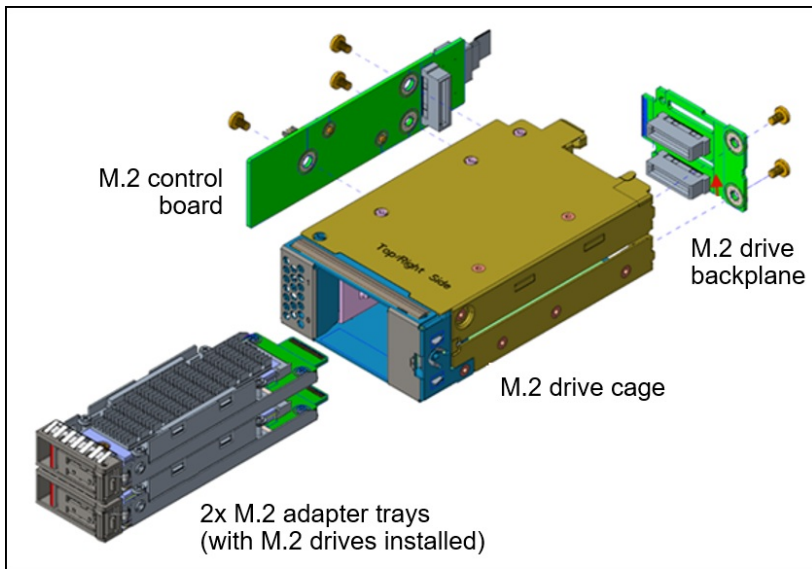

Figure 22. Front hot-swap M.2 drive bays

### M.2 ordering information

The supported M.2 module is listed in the following table. For field upgrades see the [M.2 field upgrades](#) section below.

Table 40. M.2 adapters

Part number	Feature code	Description	SATA drives	NVMe drives	RAID	Max Qty
Internal M.2 (non-hot-swap)						
4Y37A91802	C0JK	ThinkSystem M.2 B340i-2i NVMe Enablement Adapter	No	Yes (x2 lanes per drive)	VROC	1
4Y37A93746	C26V	ThinkSystem M.2 RAID B545i-2i SATA/NVMe Adapter	Yes	Yes (x1 lane per drive)	Integrated (Broadcom)	1
Rear hot-swap M.2						
4XH7B03860	C0JJ	ThinkSystem SR650/a V4 M.2 RAID B450p-2HS SATA/NVMe Enablement Kit <ul style="list-style-type: none"> <li>• M.2 rear drive cage for FH slot</li> <li>• M.2 rear drive cage for 2xFH slots</li> <li>• M.2 2-drive hot-swap backplane</li> <li>• 2x empty M.2 hot-swap adapter tray</li> <li>• Signal and power cables</li> </ul>	Yes	Yes (x1 lane per drive)	Integrated (Broadcom)	1
Front hot-swap M.2						
4XH7B03857	C217	ThinkSystem SR650/a V4 M.2 RAID B540d-2HS SATA/NVMe Enablement Kit <ul style="list-style-type: none"> <li>• M.2 front drive cage</li> <li>• M.2 2-drive hot-swap backplane</li> <li>• M.2 control board</li> <li>• 2x empty M.2 hot-swap adapter trays</li> <li>• Signal and power cables</li> </ul>	Yes	Yes (x1 lane per drive)	Integrated (Broadcom)	1

Configuration notes:

- M.2 is not supported with all storage configurations - see [Storage configurations](#) for details.
- For CTO orders, all other necessary components, except for the M.2 drives themselves, will be automatically included in the order. For drives, see the [Internal drive options](#) section.
- For field upgrades of the internal M.2, an additional cable is needed as described in the [M.2 field upgrades for internal M.2](#) section below.
- For field upgrades of the rear or front hot-swap M.2, one additional kit is needed for each M.2 drive you plan to install, as described in the [M.2 field upgrades for hot-swap M.2](#) section below.
- Rear M.2 is not supported with open-loop water cooling

**VROC RAID support for the B340i-2i adapter**

ThinkSystem M.2 B340i-2i NVMe Enablement Adapter (4Y37A91802) optionally supports RAID with the use of Intel VROC. For CTO orders, ordering information is listed in the following table.

Table 41. CTO feature codes to select VROC RAID for ThinkSystem M.2 B340i-2i NVMe Enablement Adapter (4Y37A91802)

Part number	Feature code	Description	Max Qty	RAID support
VROC NVMe RAID for ThinkSystem M.2 B340i-2i NVMe Enablement Adapter (4Y37A91802)				
4L47A92670*	BZ4X	Intel VROC RAID1 Only for M.2	1	RAID-1
4L47A83669*	BS7M	Intel VROC (VMD NVMe RAID) Standard for M.2	1	RAID-0,1

\* The part numbers enable VROC for all installed drives, not just M.2

## M.2 adapter features

The ThinkSystem M.2 B340i-2i NVMe Enablement Adapter (4Y37A91802) has the following features:

- Supports one or two NVMe M.2 drives (SATA not supported)
- Drives are not hot-swap
- Support M.2 2280 (80mm) drive form factor only
- No built-in RAID support (optionally supports Intel VROC NVMe RAID)
- PCIe 5.0 x4 host interface; PCIe 5.0 x2 connection to each drive
- Management and configuration support via UEFI and OS-based tools
- Supports monitoring and reporting of events and temperature
- Firmware update via Lenovo firmware update tools
- Supports SED drive encryption

The ThinkSystem M.2 RAID B545i-2i SATA/NVMe Adapter (4Y37A93746) has the following features:

- Supports one or two M.2 drives, either SATA or NVMe
- Drives are not hot-swap
- Supports M.2 2242, 2260, 2280 drive form factors (42mm, 60mm, 80mm)
- RAID support via an onboard Broadcom SAS3808N RAID Controller
- With 1 drive, supports JBOD
- With 2 drives, supports 2-drive RAID-0, 2-drive RAID-1, or JBOD (default is RAID-1)
- PCIe 4.0 x2 host interface; PCIe 4.0 x1 connection to each drive
- Management and configuration support via UEFI and OS-based tools
- Supports monitoring and reporting of events and temperature
- Firmware update via Lenovo firmware update tools
- Supports SED drive encryption

The ThinkSystem SR650/a V4 M.2 RAID B450p-2HS SATA/NVMe Enablement Kit (4XH7B03860) has the following features:

- Supports one or two M.2 drives, either SATA or NVMe
- Each drive is installed in a hot-swap carrier
- Support M.2 2280 (80mm) drive form factor only
- RAID support via an onboard Broadcom SAS3808N RAID Controller
- With 1 drive, supports JBOD
- With 2 drives, supports 2-drive RAID-0, 2-drive RAID-1, or JBOD (default is RAID-1)
- PCIe 4.0 x2 host interface; PCIe 4.0 x1 connection to each drive
- Management and configuration support via UEFI and OS-based tools
- Supports monitoring and reporting of events and temperature
- Firmware update via Lenovo firmware update tools
- Supports SED drive encryption

The ThinkSystem SR650/a V4 M.2 RAID B540d-2HS SATA/NVMe Enablement Kit (4XH7B03857) has the following features:

- Supports one or two M.2 drives, either SATA or NVMe
- Each drive is installed in a hot-swap carrier
- Support M.2 2280 (80mm) drive form factor only
- RAID support via an onboard Broadcom SAS3808N RAID Controller
- With 1 drive, supports JBOD
- With 2 drives, supports 2-drive RAID-0, 2-drive RAID-1, or JBOD (default is RAID-1)
- PCIe 4.0 x2 host interface; PCIe 4.0 x1 connection to each drive
- Management and configuration support via UEFI and OS-based tools
- Supports monitoring and reporting of events and temperature
- Firmware update via Lenovo firmware update tools
- Supports SED drive encryption

## M.2 field upgrades for internal M.2

For field upgrades to add one of the supported internal M.2 adapters, the SR650 V4 also requires an additional M.2 cable kit. Ordering information is listed in the following table.

Table 42. M.2 Cable Kits for field upgrades to add an internal M.2 adapter

Part number	Description	Qty
4XH7B03859	ThinkSystem SR650/a V4 Internal M.2 Enablement Cable kit	1

### M.2 field upgrades for hot-swap M.2

This section applies to both the front hot-swap M.2 and rear hot-swap M.2.

In addition to the M.2 adapter kit (4XH7B03860 for rear, or 4XH7B03857 for front as listed in the [M.2 adapters table](#)), for each M.2 drive you want to add to the server as a hot-swap drive, you will also need to a drive kit which supplies the M.2 adapter, drive tray, and drive heatsink that are needed. One kit is required for each M.2 drive.

Table 43. M.2 kit for field upgrades to add hot-swap M.2 drives

Part number	Description	Qty
4XH7A96837	ThinkSystem V4 Hot Swap M.2 SATA/NVMe Drive Assembly Kit (see below) <ul style="list-style-type: none"> <li>• M.2 adapter</li> <li>• M.2 drive tray</li> <li>• M.2 drive heatsink</li> </ul>	1 per drive

The following figure shows the components of the ThinkSystem V4 Hot Swap M.2 SATA/NVMe Drive Assembly Kit (4XH7A96837), used for hot-swap M.2 (for both front and rear drive bays, not for internal M.2). The M.2 drive needs to be ordered separately.

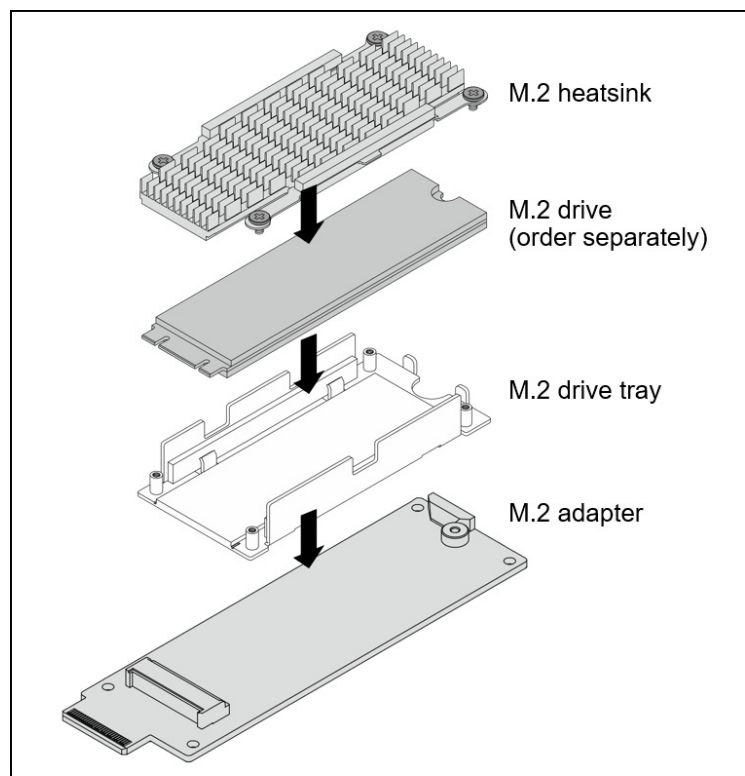

Figure 23. Components of the ThinkSystem V4 Hot Swap M.2 SATA/NVMe Drive Assembly Kit

### SED encryption key management with SKLM

The server supports self-encrypting drives (SEDs) as listed in the [Internal drive options](#) section. To effectively manage a large deployment of these drives in Lenovo servers, IBM Security Key Lifecycle Manager (SKLM) offers a centralized key management solution.

The IBM Security Key Lifecycle Manager software is available from Lenovo using the ordering information listed in the following table.

Table 44. IBM Security Key Lifecycle Manager licenses

Part number	Feature	Description
<b>SKLM Basic Edition</b>		
7S0A007FWW	S874	IBM Security Key Lifecycle Manager Basic Edition Install License + SW Subscription & Support 12 Months
7S0A008VWW	SDJR	IBM Security Key Lifecycle Manager Basic Edition Install License + SW Subscription & 3 Years Of Support
7S0A008WVWW	SDJS	IBM Security Key Lifecycle Manager Basic Edition Install License + SW Subscription & 4 Years Of Support
7S0A008XWW	SDJT	IBM Security Key Lifecycle Manager Basic Edition Install License + SW Subscription & 5 Years Of Support
<b>SKLM For Raw Decimal Terabyte Storage</b>		
7S0A007HWW	S876	IBM Security Key Lifecycle Manager For Raw Decimal Terabyte Storage Resource Value Unit License + SW Subscription & Support 12 Months
7S0A008YWW	SDJU	IBM Security Key Lifecycle Manager For Raw Decimal Terabyte Storage Resource Value Unit License + SW Subscription & 3 Years Of Support
7S0A008ZWW	SDJV	IBM Security Key Lifecycle Manager For Raw Decimal Terabyte Storage Resource Value Unit License + SW Subscription & 4 Years Of Support
7S0A0090WW	SDJW	IBM Security Key Lifecycle Manager For Raw Decimal Terabyte Storage Resource Value Unit License + SW Subscription & 5 Years Of Support
<b>SKLM For Raw Decimal Petabyte Storage</b>		
7S0A007KWW	S878	IBM Security Key Lifecycle Manager For Raw Decimal Petabyte Storage Resource Value Unit License + SW Subscription & Support 12 Months
7S0A0091WW	SDJX	IBM Security Key Lifecycle Manager For Raw Decimal Petabyte Storage Resource Value Unit License + SW Subscription & 3 Years Of Support
7S0A0092WW	SDJY	IBM Security Key Lifecycle Manager For Raw Decimal Petabyte Storage Resource Value Unit License + SW Subscription & 4 Years Of Support
7S0A0093WW	SDJZ	IBM Security Key Lifecycle Manager For Raw Decimal Petabyte Storage Resource Value Unit License + SW Subscription & 5 Years Of Support
<b>SKLM For Usable Decimal Terabyte Storage</b>		
7S0A007MWW	S87A	IBM Security Key Lifecycle Manager For Usable Decimal Terabyte Storage Resource Value Unit License + SW Subscription & Support 12 Months
7S0A0094WW	SDK0	IBM Security Key Lifecycle Manager For Usable Decimal Terabyte Storage Resource Value Unit License + SW Subscription & 3 Years In Support
7S0A0095WW	SDK1	IBM Security Key Lifecycle Manager For Usable Decimal Terabyte Storage Resource Value Unit License + SW Subscription & 4 Years In Support
7S0A0096WW	SDK2	IBM Security Key Lifecycle Manager For Usable Decimal Terabyte Storage Resource Value Unit License + SW Subscription & 5 Years In Support
<b>SKLM For Usable Decimal Petabyte Storage</b>		
7S0A007PWW	S87C	IBM Security Key Lifecycle Manager For Usable Decimal Petabyte Storage Resource Value Unit License + SW Subscription & Support 12 Months
7S0A0097WW	SDK3	IBM Security Key Lifecycle Manager For Usable Decimal Petabyte Storage Resource Value Unit License + SW Subscription & 3 Years Of Support

Part number	Feature	Description
7S0A0098WW	SDK4	IBM Security Key Lifecycle Manager For Usable Decimal Petabyte Storage Resource Value Unit License + SW Subscription & 4 Years Of Support
7S0A0099WW	SDK5	IBM Security Key Lifecycle Manager For Usable Decimal Petabyte Storage Resource Value Unit License + SW Subscription & 5 Years Of Support

## Controllers for internal storage

The SR650 V4 offers a variety of controller options for internal drives:

- For 2.5-inch and 3.5-inch drives:
  - RAID adapters and HBAs for SAS/SATA drives (PCIe slot-based)
  - RAID adapters and HBAs for SAS/SATA drives (cabled in a dedicated space)
  - Onboard NVMe ports with RAID support using Intel VROC NVMe RAID
  - Tri-Mode support using RAID 940 adapters for NVMe drives, with RAID provided by the RAID adapter
- For E3.S EDSFF drives:
  - Onboard NVMe ports with RAID support using Intel VROC NVMe RAID
- For M.2 drives (see [M.2 drives](#) section)
  - SATA controller integrated on the M.2 adapters
  - NVMe controller integrated on the M.2 adapters (Intel VROC for RAID)

As well as supporting RAID adapters and HBAs that install in a PCIe slot, the SR650 V4 with 2.5-inch front drive bays supports a custom form factor (CFF) adapter that is mounted in the server and cabled to one of the onboard NVMe ports.

The following table lists the adapters used for the internal storage of the server. For VROC ordering information, see the [Intel VROC](#) section.

**No Onboard SATA support:** The processors in the SR650 V4 do not offer onboard SATA support. For SATA drives, you will need either a RAID adapter or an HBA.

Table 45. Storage controller support for internal drives

Part number	Feature code	Description	Max Qty	Slots	Supercap
Onboard NVMe - PCIe 5.0 - RAID using <a href="#">Intel VROC</a> .					
CTO only	BC4V	Non RAID NVMe	1	None	No
SAS HBA - PCIe 3.0					
4Y37A72481	BJHJ	ThinkSystem 4350-16i SAS/SATA 12Gb HBA	2	1-10	No
SAS HBA - PCIe 4.0					
4Y37A78602	BM50	ThinkSystem 440-16i SAS/SATA PCIe Gen4 12Gb HBA	2	1-10	No
4Y37A09725	B8P1	ThinkSystem 440-16i SAS/SATA PCIe Gen4 12Gb Internal HBA	1	CFF*	No
SAS Expander					
4Y37A09736	B8P6	ThinkSystem 48 port 12Gb Internal Expander	1	CFF*	No
RAID Adapter - PCIe 3.0					
4Y37A72482	BJHK	ThinkSystem RAID 5350-8i PCIe 12Gb Adapter	3	1-10	No
4Y37A72483	BJHL	ThinkSystem RAID 9350-8i 2GB Flash PCIe 12Gb Adapter	3	1-10	Included
4Y37A72485	BJHN	ThinkSystem RAID 9350-16i 4GB Flash PCIe 12Gb Adapter	2	1-10	Included
RAID Adapter - PCIe 4.0					
4Y37A93012	C0TU	ThinkSystem RAID 545-8i PCIe Gen4 12Gb Adapter	3	1-10	No
4Y37A09728	B8NY	ThinkSystem RAID 940-8i 4GB Flash PCIe Gen4 12Gb Adapter	3	1-10	Included
4Y37A09730	B8NZ	ThinkSystem RAID 940-16i 8GB Flash PCIe Gen4 12Gb Adapter	2	1-10	Included
4Y37A09735	B8P0	ThinkSystem RAID 940-16i 8GB Flash PCIe Gen4 12Gb Internal Adapter	1	CFF*	Included
NVMe (Tri-Mode support)					
4Y37A09728†	BGM1	ThinkSystem RAID 940-8i 4GB Flash PCIe Gen4 12Gb Adapter for U.3	3	1-10	Included
4Y37A09730†	BDY4	ThinkSystem Raid 940-16i 8GB Flash PCIe Gen4 12Gb Adapter for U.3	1	1-10	Included
4Y37A09735†	BGM2	ThinkSystem RAID 940-16i 8GB Flash PCIe Gen4 12Gb Internal Adapter for U.3	1	CFF*	Included

\* CFF (custom form factor) is the name for the cabled internal adapter form factor that doesn't occupy a standard PCIe slot

† with Tri-Mode enabled, the adapter supports PCIe 4.0 x1 connectivity to NVMe drives with U.3 interface

Configuration notes:

- **Supercap support limits the number of RAID adapters installable** : The table lists whether the adapter includes a power module (supercap) to power the flash memory. The server supports between 1 and 3 supercaps depending on the server configuration as described in the [RAID flash power module \(supercap\) support](#) section. The number of supercaps supported also determines the maximum number of RAID adapters with flash that can be installed in the server.
- **Field upgrades**: If you are adding a RAID adapter with supercap to the server as a field upgrade, you may need a supercap holder as described in the [RAID flash power module \(supercap\) support](#) section.

The onboard NVMe support has the following features:

- Support integrated into the Intel processor
- Each drive has PCIe 5.0 x4 host interface
- Supports JBOD
- Supports RAID using Intel VROC

For specifications about the RAID adapters and HBAs supported by the SR650 V4, see the ThinkSystem RAID Adapter and HBA Comparison, available from:  
<https://lenovopress.com/lp1288-lenovo-thinksystem-raid-adapter-and-hba-reference#sr650-v4-support=SR650%2520V4>

For details about these adapters, see the relevant product guide:

- SAS HBAs: <https://lenovopress.com/servers/options/hba>
- RAID adapters: <https://lenovopress.com/servers/options/raid>

### RAID 940 Tri-Mode support

The RAID 940-8i and RAID 940-16i adapters also support NVMe through a feature named Tri-Mode support (or Trimode support). This feature enables the use of NVMe U.3 drives at the same time as SAS and SATA drives. Tri-Mode requires an AnyBay backplane. Cabling of the controller to the backplanes is the same as with SAS/SATA drives, and the NVMe drives are connected via a PCIe x1 link to the controller.

NVMe drives connected using Tri-Mode support provide better performance than SAS or SATA drives: A SATA SSD has a data rate of 6Gbps, a SAS SSD has a data rate of 12Gbps, whereas an NVMe U.3 Gen 4 SSD with a PCIe x1 link will have a data rate of 16Gbps. NVMe drives typically also have lower latency and higher IOPS compared to SAS and SATA drives. Tri-Mode is supported with U.3 NVMe drives and requires an AnyBay backplane.

**Tri-Mode requires U.3 drives:** Only NVMe drives with a U.3 interface are supported. U.2 drives are not supported. See the [Internal drive options](#) section for the U.3 drives supported by the server.

### Intel VROC onboard RAID

Intel VROC (Virtual RAID on CPU) is a feature of the Intel processor that enables Integrated RAID support.

On the SR650 V4, Intel VROC provides RAID functions for the onboard NVMe controller (Intel VROC NVMe RAID).

VROC NVMe RAID offers RAID support for any NVMe drives directly connected to the ports on the server's system board or via adapters such as NVMe retimers or NVMe switch adapters. On the SR650 V4, RAID levels implemented are based on the VROC feature selected as indicated in the following table. RAID 1 is limited to 2 drives per array, and RAID 10 is limited to 4 drives per array. Hot-spare functionality is also supported.

**Performance tip:** For best performance with VROC NVMe RAID, the drives in an array should all be connected to the same processor. Spanning processors is possible however performance will be unpredictable and should be evaluated based on your workload.

The SR650 V4 supports the VROC NVMe RAID offerings listed in the following table.

Table 46. Intel VROC NVMe RAID ordering information and feature support

Part number	Feature code	Description	Intel NVMe SSDs	Non-Intel NVMe SSDs	RAID 0	RAID 1	RAID 10	RAID 5
4L47A92670	BZ4W	Intel VROC RAID1 Only	Yes	Yes	No	Yes	No	No
4L47A83669	BR9B	Intel VROC (VMD NVMe RAID) Standard	Yes	Yes	Yes	Yes	Yes	No
4L47A39164	B96G	Intel VROC (VMD NVMe RAID) Premium	Yes	Yes	Yes	Yes	Yes	Yes

Configuration notes:

- If a feature code is ordered in a CTO build, the VROC functionality is enabled in the factory. For field

upgrades, order a part number and it will be fulfilled as a Feature on Demand (FoD) license which can then be activated via the XCC management processor user interface.

- Intel VROC NVMe is supported on all Intel Xeon Scalable processors

**Virtualization support:** Virtualization support for Intel VROC is as follows:

- **VROC (VMD) NVMe RAID :** VROC (VMD) NVMe RAID is supported by ESXi, KVM, Xen, and Hyper-V. ESXi support is limited to RAID 1 only; other RAID levels are not supported. Windows and Linux OSes support VROC RAID NVMe, both for host boot functions and for guest OS function, and RAID-0, 1, 5, and 10 are supported. On ESXi, VROC is supported with both boot and data drives.

**VROC restriction with CXL memory :** VROC NVMe RAID is currently not supported with the following CXL memory configurations:

- Configurations with a mix of CXL memory (E3.S 2T) bays and E3.S 1T drive bays
- Configurations with CXL memory (E3.S 2T) bays and M.2 drives

CXL memory configurations without E3.S 1T drives or without M.2 drives are not affected and are supported. This restriction is planned to be removed with a firmware update planned for 2Q/2025.

## Internal drive options

The following tables list the drive options for internal storage of the server.

2.5-inch hot-swap drives:

- [2.5-inch hot-swap 12 Gb SAS HDDs](#)
- [2.5-inch hot-swap 24 Gb SAS SSDs](#)
- [2.5-inch hot-swap 6 Gb SATA SSDs](#)
- [2.5-inch hot-swap PCIe 5.0 NVMe SSDs](#)
- [2.5-inch hot-swap PCIe 4.0 NVMe SSDs](#)

EDSFF hot-swap drives:

- [E3.S 1T EDSFF hot-swap PCIe 5.0 NVMe SSDs](#)

3.5-inch hot-swap drives:

- [3.5-inch hot-swap 12 Gb SAS HDDs](#)
- [3.5-inch hot-swap 6 Gb SATA HDDs](#)
- [3.5-inch hot-swap 24 Gb SAS SSDs](#)
- [3.5-inch hot-swap 6 Gb SATA SSDs](#)
- [3.5-inch hot-swap PCIe 5.0 NVMe SSDs](#)
- [3.5-inch hot-swap PCIe 4.0 NVMe SSDs](#)

M.2 drives:

- [M.2 SATA drives](#)
- [M.2 PCIe 4.0 NVMe drives](#)

**M.2 drive support:** The use of M.2 drives requires an additional adapter as described in the [M.2 drives](#) subsection.

**SED support:** The tables include a column to indicate which drives support SED encryption. The encryption functionality can be disabled if needed. Note: Not all SED-enabled drives have "SED" in the description.

Table 47. 2.5-inch hot-swap 12 Gb SAS HDDs

Part number	Feature code	Description	SED support	Max Qty
<b>2.5-inch hot-swap HDDs - 12 Gb SAS 10K</b>				
7XB7A00025	AULZ	ThinkSystem 2.5" 600GB 10K SAS 12Gb Hot Swap 512n HDD	No	40
7XB7A00027	AUM1	ThinkSystem 2.5" 1.2TB 10K SAS 12Gb Hot Swap 512n HDD	No	40
4XB7A83970	BRG7	ThinkSystem 2.5" 2.4TB 10K SAS 12Gb Hot Swap 512e HDD v2	No	40

Table 48. 2.5-inch hot-swap 24 Gb SAS SSDs

Part number	Feature code	Description	SED support	Max Qty
<b>2.5-inch hot-swap SSDs - 24 Gb SAS - Mixed Use/Mainstream (3-5 DDPD)</b>				
4XB7A80340	BNW8	ThinkSystem 2.5" PM1655 800GB Mixed Use SAS 24Gb HS SSD	Support	40
4XB7A80341	BNW9	ThinkSystem 2.5" PM1655 1.6TB Mixed Use SAS 24Gb HS SSD	Support	40
4XB7A80342	BNW6	ThinkSystem 2.5" PM1655 3.2TB Mixed Use SAS 24Gb HS SSD	Support	40
4XB7A80343	BP3K	ThinkSystem 2.5" PM1655 6.4TB Mixed Use SAS 24Gb HS SSD	Support	40
<b>2.5-inch hot-swap SSDs - 24 Gb SAS - Read Intensive/Entry/Capacity (&lt;3 DDPD)</b>				
4XB7A80318	BNWC	ThinkSystem 2.5" PM1653 960GB Read Intensive SAS 24Gb HS SSD	Support	40
4XB7A80319	BNWE	ThinkSystem 2.5" PM1653 1.92TB Read Intensive SAS 24Gb HS SSD	Support	40
4XB7A80320	BNWF	ThinkSystem 2.5" PM1653 3.84TB Read Intensive SAS 24Gb HS SSD	Support	40
4XB7A80321	BP3E	ThinkSystem 2.5" PM1653 7.68TB Read Intensive SAS 24Gb HS SSD	Support	40
4XB7A80322	BP3J	ThinkSystem 2.5" PM1653 15.36TB Read Intensive SAS 24Gb HS SSD	Support	40
4XB7A80323	BP3D	ThinkSystem 2.5" PM1653 30.72TB Read Intensive SAS 24Gb HS SSD	Support	40

Table 49. 2.5-inch hot-swap 6 Gb SATA SSDs

Part number	Feature code	Description	SED support	Max Qty
<b>2.5-inch hot-swap SSDs - 6 Gb SATA - Mixed Use/Mainstream (3-5 DWPD)</b>				
4XB7A93091	C1X3	ThinkSystem 2.5" PM897a 480GB Mixed Use SATA 6Gb HS SSD	Support	40
4XB7A93092	C1X4	ThinkSystem 2.5" PM897a 960GB Mixed Use SATA 6Gb HS SSD	Support	40
4XB7A93093	C1X5	ThinkSystem 2.5" PM897a 1.92TB Mixed Use SATA 6Gb HS SSD	Support	40
4XB7A93094	C1X6	ThinkSystem 2.5" PM897a 3.84TB Mixed Use SATA 6Gb HS SSD	Support	40
4XB7A90884	BYM2	ThinkSystem 2.5" VA 480GB Mixed Use SATA 6Gb HS SSD v2	No	40
4XB7A90885	BYM4	ThinkSystem 2.5" VA 960GB Mixed Use SATA 6Gb HS SSD v2	No	40
4XB7A90886	BYM5	ThinkSystem 2.5" VA 1.92TB Mixed Use SATA 6Gb HS SSD v2	No	40
4XB7A90887	BYM6	ThinkSystem 2.5" VA 3.84TB Mixed Use SATA 6Gb HS SSD v2	No	40
4XB7A82289	BQ21	ThinkSystem 2.5" 5400 MAX 480GB Mixed Use SATA 6Gb HS SSD	Support	40
4XB7A82290	BQ24	ThinkSystem 2.5" 5400 MAX 960GB Mixed Use SATA 6Gb HS SSD	Support	40
4XB7A82291	BQ22	ThinkSystem 2.5" 5400 MAX 1.92TB Mixed Use SATA 6Gb HS SSD	Support	40
4XB7A82292	BQ23	ThinkSystem 2.5" 5400 MAX 3.84TB Mixed Use SATA 6Gb HS SSD	Support	40
<b>2.5-inch hot-swap SSDs - 6 Gb SATA - Read Intensive/Entry (&lt;3 DWPD)</b>				
4XB7A90872	BYLQ	ThinkSystem 2.5" VA 240GB Read Intensive SATA 6Gb HS SSD v2	No	40
4XB7A90873	BYLR	ThinkSystem 2.5" VA 480GB Read Intensive SATA 6Gb HS SSD v2	No	40
4XB7A90874	BYLS	ThinkSystem 2.5" VA 960GB Read Intensive SATA 6Gb HS SSD v2	No	40
4XB7A90875	BYLT	ThinkSystem 2.5" VA 1.92TB Read Intensive SATA 6Gb HS SSD v2	No	40
4XB7A90876	BYLU	ThinkSystem 2.5" VA 3.84TB Read Intensive SATA 6Gb HS SSD v2	No	40
4XB7A90877	BYLV	ThinkSystem 2.5" VA 7.68TB Read Intensive SATA 6Gb HS SSD v2	No	40
4XB7A87524	BWKN	ThinkSystem 2.5" PM893a 480GB Read Intensive SATA 6Gb HS SSD	Support	40
4XB7A87525	BWKM	ThinkSystem 2.5" PM893a 960GB Read Intensive SATA 6Gb HS SSD	Support	40
4XB7A87526	BWKL	ThinkSystem 2.5" PM893a 1.92TB Read Intensive SATA 6Gb HS SSD	Support	40
4XB7A87527	BWKK	ThinkSystem 2.5" PM893a 3.84TB Read Intensive SATA 6Gb HS SSD	Support	40
4XB7A82258	BQ1Q	ThinkSystem 2.5" 5400 PRO 240GB Read Intensive SATA 6Gb HS SSD	Support	40
4XB7A82260	BQ1R	ThinkSystem 2.5" 5400 PRO 960GB Read Intensive SATA 6Gb HS SSD	Support	40
4XB7A82261	BQ1X	ThinkSystem 2.5" 5400 PRO 1.92TB Read Intensive SATA 6Gb HS SSD	Support	40
4XB7A82262	BQ1S	ThinkSystem 2.5" 5400 PRO 3.84TB Read Intensive SATA 6Gb HS SSD	Support	40
4XB7A82263	BQ1T	ThinkSystem 2.5" 5400 PRO 7.68TB Read Intensive SATA 6Gb HS SSD	Support	40

Table 50. 2.5-inch hot-swap PCIe 5.0 NVMe SSDs

Part number	Feature code	Description	SED support	Max Qty
<b>2.5-inch SSDs - U.2 PCIe 5.0 NVMe - Mixed Use/Mainstream (3-5 DWPD)</b>				
4XB7A93097	C1WM	ThinkSystem 2.5" U.2 PM9D5a 800GB Mixed Use NVMe NVMe PCIe 5.0 x4 HS SSD	Support	36
4XB7A93098	C1WN	ThinkSystem 2.5" U.2 PM9D5a 1.6TB Mixed Use NVMe NVMe PCIe 5.0 x4 HS SSD	Support	36
4XB7A93099	C1WP	ThinkSystem 2.5" U.2 PM9D5a 3.2TB Mixed Use NVMe NVMe PCIe 5.0 x4 HS SSD	Support	36
4XB7A93100	C1WR	ThinkSystem 2.5" U.2 PM9D5a 6.4TB Mixed Use NVMe NVMe PCIe 5.0 x4 HS SSD	Support	36
4XB7A93101	C1WQ	ThinkSystem 2.5" U.2 PM9D5a 12.8TB Mixed Use NVMe NVMe PCIe 5.0 x4 HS SSD	Support	36
4XB7A93127	C0ZR	ThinkSystem 2.5" U.2 VA 1.6TB Mixed Use NVMe PCIe 5.0 x4 HS SSD	Support	36
4XB7A93128	C0ZQ	ThinkSystem 2.5" U.2 VA 3.2TB Mixed Use NVMe PCIe 5.0 x4 HS SSD	Support	36
4XB7A93129	C0ZP	ThinkSystem 2.5" U.2 VA 6.4TB Mixed Use NVMe PCIe 5.0 x4 HS SSD	Support	36
4XB7A93130	C0ZN	ThinkSystem 2.5" U.2 VA 12.8TB Mixed Use NVMe PCIe 5.0 x4 HS SSD	Support	36
<b>2.5-inch SSDs - U.2 PCIe 5.0 NVMe - Read Intensive/Entry (&lt;3 DWPD)</b>				
4XB7A93066	C0GK	ThinkSystem 2.5" U.2 PM9D3a 960GB Read Intensive NVMe PCIe 5.0 x4 HS SSD	Support	36
4XB7A93067	C0GL	ThinkSystem 2.5" U.2 PM9D3a 1.92TB Read Intensive NVMe PCIe 5.0 x4 HS SSD	Support	36
4XB7A93068	C0GN	ThinkSystem 2.5" U.2 PM9D3a 3.84TB Read Intensive NVMe PCIe 5.0 x4 HS SSD	Support	36
4XB7A93069	C0GP	ThinkSystem 2.5" U.2 PM9D3a 7.68TB Read Intensive NVMe PCIe 5.0 x4 HS SSD	Support	36
4XB7A93095	C1WL	ThinkSystem 2.5" U.2 PM9D3a 15.36TB Read Intensive NVMe PCIe 5.0 x4 HS SSD	Support	36
4XB7A93122	C0ZV	ThinkSystem 2.5" U.2 VA 1.92TB Read Intensive NVMe PCIe 5.0 x4 HS SSD	Support	36
4XB7A93123	C0ZU	ThinkSystem 2.5" U.2 VA 3.84TB Read Intensive NVMe PCIe 5.0 x4 HS SSD	Support	36
4XB7A93124	C0ZT	ThinkSystem 2.5" U.2 VA 7.68TB Read Intensive NVMe PCIe 5.0 x4 HS SSD	Support	36
4XB7A93125	C0ZS	ThinkSystem 2.5" U.2 VA 15.36TB Read Intensive NVMe PCIe 5.0 x4 HS SSD	Support	36

Table 51. 2.5-inch hot-swap PCIe 4.0 NVMe SSDs

Part number	Feature code	Description	SED support	Max Qty
<b>2.5-inch SSDs - U.3 PCIe 4.0 NVMe - Mixed Use/Mainstream (3-5 DWPD)</b>				
4XB7A95054	C2BG	ThinkSystem 2.5" U.3 7500 MAX 800GB Mixed Use NVMe PCIe 4.0 x4 HS SSD	Support	36
4XB7A95055	C2BV	ThinkSystem 2.5" U.3 7500 MAX 1.6TB Mixed Use NVMe PCIe 4.0 x4 HS SSD	Support	36
4XB7A95056	C2BW	ThinkSystem 2.5" U.3 7500 MAX 3.2TB Mixed Use NVMe PCIe 4.0 x4 HS SSD	Support	36
4XB7A95057	C2BF	ThinkSystem 2.5" U.3 7500 MAX 6.4TB Mixed Use NVMe PCIe 4.0 x4 HS SSD	Support	36
4XB7A95058	C2BX	ThinkSystem 2.5" U.3 7500 MAX 12.8TB Mixed Use NVMe PCIe 4.0 x4 HS SSD	Support	36
<b>2.5-inch SSDs - U.2 PCIe 4.0 NVMe - Read Intensive/Entry (&lt;3 DWPD)</b>				
4XB7B01867	C6MA	ThinkSystem 2.5" U.2 Solidigm P5520 1.92TB Read Intensive NVMe PCIe 4.0 x4 HS SSD	Support	36
4XB7B01868	C6MB	ThinkSystem 2.5" U.2 Solidigm P5520 3.84TB Read Intensive NVMe PCIe 4.0 x4 HS SSD	Support	36
4XB7B01869	C6MC	ThinkSystem 2.5" U.2 Solidigm P5520 7.68TB Read Intensive NVMe PCIe 4.0 x4 HS SSD	Support	36
4XB7B01870	C7NZ	ThinkSystem 2.5" U.2 Solidigm P5520 15.36TB Read Intensive NVMe PCIe 4.0 x4 HS SSD	Support	36
4XB7A93075	C1WJ	ThinkSystem 2.5" U.2 P5336 30.72TB Read Intensive NVMe PCIe 4.0 x4 HS SSD	Support	36
4XB7A93076	C1WK	ThinkSystem 2.5" U.2 P5336 61.44TB Read Intensive NVMe PCIe 4.0 x4 HS SSD	Support	36
<b>2.5-inch SSDs - U.3 PCIe 4.0 NVMe - Read Intensive/Entry (&lt;3 DWPD)</b>				
4XB7A95049	C2BY	ThinkSystem 2.5" U.3 7500 PRO 960GB Read Intensive NVMe PCIe 4.0 x4 HS SSD	Support	36
4XB7A95050	C2BR	ThinkSystem 2.5" U.3 7500 PRO 1.92TB Read Intensive NVMe PCIe 4.0 x4 HS SSD	Support	36
4XB7A95051	C2BS	ThinkSystem 2.5" U.3 7500 PRO 3.84TB Read Intensive NVMe PCIe 4.0 x4 HS SSD	Support	36
4XB7A95052	C2BT	ThinkSystem 2.5" U.3 7500 PRO 7.68TB Read Intensive NVMe PCIe 4.0 x4 HS SSD	Support	36
4XB7A95053	C2BU	ThinkSystem 2.5" U.3 7500 PRO 15.36TB Read Intensive NVMe PCIe 4.0 x4 HS SSD	Support	36

Table 52. E3.S 1T EDSFF hot-swap PCIe 5.0 NVMe SSDs

Part number	Feature code	Description	SED support	Max Qty
<b>E3.S hot-swap SSDs - PCIe 5.0 NVMe - Mixed Use/Mainstream (3-5 DWPD)</b>				
4XB7A95510	C3P7	ThinkSystem E3.S CD8P 1.6TB Mixed Use NVMe PCIe 5.0 x4 HS SSD	Support	32
4XB7A95511	C3P8	ThinkSystem E3.S CD8P 3.2TB Mixed Use NVMe PCIe 5.0 x4 HS SSD	Support	32
4XB7A95512	C3P9	ThinkSystem E3.S CD8P 6.4TB Mixed Use NVMe PCIe 5.0 x4 HS SSD	Support	32
4XB7A95513	C3PA	ThinkSystem E3.S CD8P 12.8TB Mixed Use NVMe PCIe 5.0 x4 HS SSD	Support	32
4XB7A93136	C1WD	ThinkSystem E3.S 1T VA 1.6TB Mixed Use NVMe PCIe 5.0 x4 HS SSD v2	Support	32
4XB7A93137	C1WE	ThinkSystem E3.S 1T VA 3.2TB Mixed Use NVMe PCIe 5.0 x4 HS SSD v2	Support	32
4XB7A93138	C1WF	ThinkSystem E3.S 1T VA 6.4TB Mixed Use NVMe PCIe 5.0 x4 HS SSD v2	Support	32
4XB7A93139	C1WG	ThinkSystem E3.S 1T VA 12.8TB Mixed Use NVMe PCIe 5.0 x4 HS SSD v2	Support	32
<b>E3.S hot-swap SSDs - PCIe 5.0 NVMe - Read Intensive/Entry (&lt;3 DWPD)</b>				
4XB7A93132	C1W9	ThinkSystem E3.S 1T VA 3.84TB Read Intensive NVMe PCIe 5.0 x4 HS SSD v2	Support	32
4XB7A93133	C1WA	ThinkSystem E3.S 1T VA 7.68TB Read Intensive NVMe PCIe 5.0 x4 HS SSD v2	Support	32
4XB7A93134	C1WB	ThinkSystem E3.S 1T VA 15.36TB Read Intensive NVMe PCIe 5.0 x4 HS SSD v2	Support	32
4XB7A93080	C1AB	ThinkSystem E3.S PM9D3a 7.68TB Read Intensive NVMe PCIe 5.0 x4 HS SSD	Support	32
4XB7A93810	C0R2	ThinkSystem E3.S CD8P 1.92TB Read Intensive NVMe PCIe 5.0 x4 HS SSD	Support	32
4XB7A93811	C0R3	ThinkSystem E3.S CD8P 3.84TB Read Intensive NVMe PCIe 5.0 x4 HS SSD	Support	32
4XB7A93812	C0R4	ThinkSystem E3.S CD8P 7.68TB Read Intensive NVMe PCIe 5.0 x4 HS SSD	Support	32
4XB7A93813	C0R5	ThinkSystem E3.S CD8P 15.36TB Read Intensive NVMe PCIe 5.0 x4 HS SSD	Support	32

Table 53. 3.5-inch hot-swap 12 Gb SAS HDDs

Part number	Feature code	Description	SED support	Max Qty
<b>3.5-inch hot-swap HDDs - 12 Gb NL SAS</b>				
4XB7B01233	C5WY	ThinkSystem 3.5" 2TB 7.2K SAS 12Gb Hot Swap 512e HDD v2	Support	16
4XB7B01235	C5X9	ThinkSystem 3.5" 4TB 7.2K SAS 12Gb Hot Swap 512e HDD v2	Support	16
4XB7B01239	C5XD	ThinkSystem 3.5" 8TB 7.2K SAS 12Gb Hot Swap 512e HDD v2	Support	16
4XB7A93788	C4DA	ThinkSystem 3.5" 12TB 7.2K SAS 12Gb Hot Swap 512e HDD v2	Support	16
4XB7A93786	C4D8	ThinkSystem 3.5" 16TB 7.2K SAS 12Gb Hot Swap 512e HDD v2	Support	16
4XB7A93784	C4D6	ThinkSystem 3.5" 20TB 7.2K SAS 12Gb Hot Swap 512e HDD v2	Support	16
4XB7A93007	C2BH	ThinkSystem 3.5" 24TB 7.2K SAS 12Gb Hot Swap 512e HDD	Support	16
<b>3.5-inch hot-swap SED HDDs - 12 Gb NL SAS</b>				
7XB7A00066	B0YQ	ThinkSystem 3.5" 8TB 7.2K SAS 12Gb Hot Swap 512e HDD FIPS	Support	16

Table 54. 3.5-inch hot-swap 6 Gb SATA HDDs

Part number	Feature code	Description	SED support	Max Qty
<b>3.5-inch hot-swap HDDs - 6 Gb NL SATA</b>				
4XB7B01234	C5X8	ThinkSystem 3.5" 2TB 7.2K SATA 6Gb Hot Swap 512e HDD v2	Support	16
4XB7B01236	C5XA	ThinkSystem 3.5" 4TB 7.2K SATA 6Gb Hot Swap 512e HDD v2	Support	16
4XB7B01240	C5XE	ThinkSystem 3.5" 8TB 7.2K SATA 6Gb Hot Swap 512e HDD v2	Support	16
4XB7A93787	C4D9	ThinkSystem 3.5" 12TB 7.2K SATA 6Gb Hot Swap 512e HDD v2	Support	16
4XB7A93785	C4D7	ThinkSystem 3.5" 16TB 7.2K SATA 6Gb Hot Swap 512e HDD v2	Support	16
4XB7A93783	C4D5	ThinkSystem 3.5" 20TB 7.2K SATA 6Gb Hot Swap 512e HDD v2	Support	16
4XB7A93008	C2BJ	ThinkSystem 3.5" 24TB 7.2K SATA 6Gb Hot Swap 512e HDD	Support	16

Table 55. 3.5-inch hot-swap 24 Gb SAS SSDs

Part number	Feature code	Description	SED support	Max Qty
<b>3.5-inch hot-swap SSDs - 24 Gb SAS - Mixed Use/Mainstream (3-5 DWPD)</b>				
4XB7A80344	BNW7	ThinkSystem 3.5" PM1655 800GB Mixed Use SAS 24Gb HS SSD	Support	16
4XB7A80345	BNWA	ThinkSystem 3.5" PM1655 1.6TB Mixed Use SAS 24Gb HS SSD	Support	16
4XB7A80346	BNWB	ThinkSystem 3.5" PM1655 3.2TB Mixed Use SAS 24Gb HS SSD	Support	16
4XB7A80347	BP3G	ThinkSystem 3.5" PM1655 6.4TB Mixed Use SAS 24Gb HS SSD	Support	16
<b>3.5-inch hot-swap SSDs - 24 Gb SAS - Read Intensive/Entry/Capacity (&lt;3 DWPD)</b>				
4XB7A80324	BNWD	ThinkSystem 3.5" PM1653 960GB Read Intensive SAS 24Gb HS SSD	Support	16
4XB7A80325	BNWG	ThinkSystem 3.5" PM1653 1.92TB Read Intensive SAS 24Gb HS SSD	Support	16
4XB7A80326	BNWH	ThinkSystem 3.5" PM1653 3.84TB Read Intensive SAS 24Gb HS SSD	Support	16
4XB7A80327	BP3F	ThinkSystem 3.5" PM1653 7.68TB Read Intensive SAS 24Gb HS SSD	Support	16
4XB7A80328	BP3H	ThinkSystem 3.5" PM1653 15.36TB Read Intensive SAS 24Gb HS SSD	Support	16

Table 56. 3.5-inch hot-swap 6 Gb SATA SSDs

Part number	Feature code	Description	SED support	Max Qty
<b>3.5-inch hot-swap SSDs - 6 Gb SATA - Mixed Use/Mainstream (3-5 DWPD)</b>				
4XB7A90888	BYM3	ThinkSystem 3.5" VA 480GB Mixed Use SATA 6Gb HS SSD v2	No	16
4XB7A90889	BYM7	ThinkSystem 3.5" VA 960GB Mixed Use SATA 6Gb HS SSD v2	No	16
4XB7A90890	BYM8	ThinkSystem 3.5" VA 1.92TB Mixed Use SATA 6Gb HS SSD v2	No	16
4XB7A90891	BYLX	ThinkSystem 3.5" VA 3.84TB Mixed Use SATA 6Gb HS SSD v2	No	16
<b>3.5-inch hot-swap SSDs - 6 Gb SATA - Read Intensive/Entry (&lt;3 DWPD)</b>				
4XB7A90878	BYLW	ThinkSystem 3.5" VA 240GB Read Intensive SATA 6Gb HS SSD v2	No	16
4XB7A90879	BYLJ	ThinkSystem 3.5" VA 480GB Read Intensive SATA 6Gb HS SSD v2	No	16
4XB7A90880	BYLY	ThinkSystem 3.5" VA 960GB Read Intensive SATA 6Gb HS SSD v2	No	16
4XB7A90881	BYLZ	ThinkSystem 3.5" VA 1.92TB Read Intensive SATA 6Gb HS SSD v2	No	16
4XB7A90882	BYM0	ThinkSystem 3.5" VA 3.84TB Read Intensive SATA 6Gb HS SSD v2	No	16
4XB7A90883	BYM1	ThinkSystem 3.5" VA 7.68TB Read Intensive SATA 6Gb HS SSD v2	No	16

Table 57. 3.5-inch hot-swap PCIe 5.0 NVMe SSDs

Part number	Feature code	Description	SED support	Max Qty
<b>3.5-inch SSDs - U.2 PCIe 5.0 NVMe - Mixed Use/Mainstream (3-5 DWPD)</b>				
4XB7A93102	C3Q5	ThinkSystem 3.5" U.2 PM9D5a 1.6TB Mixed Use NVMe PCIe 5.0 x4 HS SSD	Support	4
4XB7A93103	C3Q4	ThinkSystem 3.5" U.2 PM9D5a 3.2TB Mixed Use NVMe PCIe 5.0 x4 HS SSD	Support	4
<b>3.5-inch SSDs - U.2 PCIe 5.0 NVMe - Read Intensive/Entry (&lt;3 DWPD)</b>				
4XB7A93096	C3Q7	ThinkSystem 3.5" U.2 PM9D3a 1.92TB Read Intensive NVMe PCIe 5.0 x4 HS SSD	Support	4
4XB7A93070	C3Q6	ThinkSystem 3.5" U.2 PM9D3a 3.84TB Read Intensive NVMe PCIe 5.0 x4 HS SSD	Support	4

Table 58. 3.5-inch hot-swap PCIe 4.0 NVMe SSDs

Part number	Feature code	Description	SED support	Max Qty
<b>3.5-inch SSDs - U.2 PCIe 4.0 NVMe - Read Intensive/Entry (&lt;3 DWPD)</b>				
4XB7B01873	C6MF	ThinkSystem 3.5" U.2 Solidigm P5520 7.68TB Read Intensive NVMe PCIe 4.0 x4 HS SSD	Support	4
4XB7B01874	C7P0	ThinkSystem 3.5" U.2 Solidigm P5520 15.36TB Read Intensive NVMe PCIe 4.0 x4 HS SSD	Support	4
<b>3.5-inch SSDs - U.3 PCIe 4.0 NVMe - Read Intensive/Entry (&lt;3 DWPD)</b>				
4XB7B05733	C9ZW	ThinkSystem 3.5" U.3 7500 PRO 1.92TB Read Intensive NVMe PCIe 4.0 x4 HS SSD	Support	4
4XB7B05734	C9ZX	ThinkSystem 3.5" U.3 7500 PRO 3.84TB Read Intensive NVMe PCIe 4.0 x4 HS SSD	Support	4
4XB7B05735	C9ZY	ThinkSystem 3.5" U.3 7500 PRO 7.68TB Read Intensive NVMe PCIe 4.0 x4 HS SSD	Support	4
4XB7B05736	C9ZZ	ThinkSystem 3.5" U.3 7500 PRO 15.36TB Read Intensive NVMe PCIe 4.0 x4 HS SSD	Support	4

Table 59. M.2 SATA drives

Part number	Feature code	Description	SED support	Max Qty
<b>M.2 SSDs - 6 Gb SATA - Read Intensive/Entry (&lt;3 DWPD)</b>				
4XB7A89422	BYF7	ThinkSystem M.2 ER3 240GB Read Intensive SATA 6Gb NHS SSD	Support	2
4XB7A90049	BYF8	ThinkSystem M.2 ER3 480GB Read Intensive SATA 6Gb NHS SSD	Support	2
4XB7A90230	BYF9	ThinkSystem M.2 ER3 960GB Read Intensive SATA 6Gb NHS SSD	Support	2
4XB7A82286	BQ1Z	ThinkSystem M.2 5400 PRO 240GB Read Intensive SATA 6Gb NHS SSD	Support	2
4XB7A82287	BQ1Y	ThinkSystem M.2 5400 PRO 480GB Read Intensive SATA 6Gb NHS SSD	Support	2
4XB7A82288	BQ20	ThinkSystem M.2 5400 PRO 960GB Read Intensive SATA 6Gb NHS SSD	Support	2

Table 60. M.2 PCIe 4.0 NVMe drives

Part number	Feature code	Description	SED support	Max Qty
<b>M.2 SSDs - PCIe 4.0 NVMe - Read Intensive/Entry (&lt;3 DWPD)</b>				
4XB7A82636	BS2P	ThinkSystem M.2 7450 PRO 480GB Read Intensive NVMe PCIe 4.0 x4 NHS SSD	Support	2
4XB7A13999	BKSR	ThinkSystem M.2 7450 PRO 960GB Read Intensive NVMe PCIe 4.0 x4 NHS SSD	Support	2

## USB flash drive

For general portable storage needs, the server also supports the USB flash drive option that is listed in the following table.

Table 61. USB memory key

Part number	Feature	Description
4X77A95465	C44Q	ThinkSystem USB 64GB USB 3.0 Flash Drive

## Internal backup units

The server does not support any internal backup units, such as tape drives or RDX drives. External backup units are available as described in the [External backup units](#) section.

## Optical drives

The server supports the external USB optical drive listed in the following table.

Table 62. External optical drive

Part number	Feature code	Description
7XA7A05926	AVV8	ThinkSystem External USB DVD RW Optical Disk Drive

The drive is based on the Lenovo Slim DVD Burner DB65 drive and supports the following formats: DVD-RAM, DVD-RW, DVD+RW, DVD+R, DVD-R, DVD-ROM, DVD-R DL, CD-RW, CD-R, CD-ROM.

## I/O expansion

The SR650 V4 supports a total of up to 10x PCIe slots plus 2x OCP slots, all at the rear of the server. Slot availability is based on riser selection and drive bays configured.

**Internal (CFF) RAID adapter/HBA:** For configurations with 2.5-inch front drive bays, an internal RAID adapter or HBA (also known as CFF or custom form factor) can be installed in a dedicated space and cabled to a PCIe 4.0 x8 connector, thereby freeing up a slot for other purposes. E3.S configurations do not support a RAID adapter.

Topics in this section:

- [Slot ordering information](#)
- [Slot configurations](#)
- [Slot field upgrades](#)
- [OCP slot filler](#)
- [Serial port](#)

The following figure shows the locations of the rear-accessible slots. The rear OCP slots are located below the PCIe slots. All slots are PCIe Gen 5.

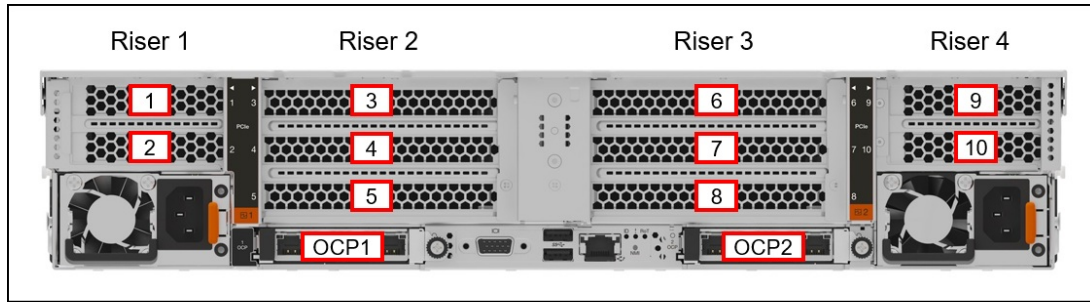

Figure 24. SR650 V4 rear slots

The supported slot and riser card combinations are as follows:

- Riser 1: Slots 1 & 2 (connects to CPU 1), low-profile slots (full height when configured with 8x 2.5-inch rear drive bays)
  - x8, x8
  - x8, x16 (only supported when configured with 8x 2.5-inch rear drive bays)
- Riser 2: Slots 3, 4 & 5 (connects to CPU 1), full-height slots
  - x8, x16, x16 (most configurations)
  - Empty, x16, x16 (use with double-wide GPU in slot 4)
  - x16, x16, x16 (for configurations with 4x 2.5-inch rear drive bays)
  - Empty, Empty, x16 (use with 4x3.5-inch or 8x2.5-inch rear drive bays)
  - Other configurations available
- Riser 3: Slots 6, 7 & 8 (connects to CPU 2), full-height slots
  - x8, x16, x16 (most configurations)
  - Empty, x16, x16 (use with double-wide GPU in slot 7)
  - Empty, Empty, x16 (use with any 2.5-inch or 3.5-inch rear drive bays)
  - Other configurations available
- Riser 4: Slots 9 & 10 (connects to CPU 2), low-profile slots
  - x8, x8
  - x8, Empty

For details, see the [Slot configurations](#) section.

All x8 slots are open-ended slots, which means they can physically support x16 adapters even though only 8 lanes (x8) will be connected.

In addition, the server has two OCP slots:

- OCP1 (connects to CPU 1)
  - Choice 1: x8
  - Choice 2: x16 (requires ThinkSystem SR650 V4/SR630 V4 x16 OCP Cable Kit, feature C1YK)
- OCP2 (connects to CPU 2)
  - Choice 1: x8
  - Choice 2: x16 (requires ThinkSystem SR650 V4/SR630 V4 x16 OCP Cable Kit, feature C1YK)

Slots can be used in conjunction with rear 2.5-inch or 3.5-inch drive bays. Slot 8 can instead be configured as a pair of hot-swap M.2 drives. Combinations are shown in the following figure.

**Riser 1 slots:** With most configurations, slots 1 and 2 (Riser 1) are Low Profile slots, however with the 8x 2.5-inch drive configuration, the slots in Riser 1 are Full Height slots.

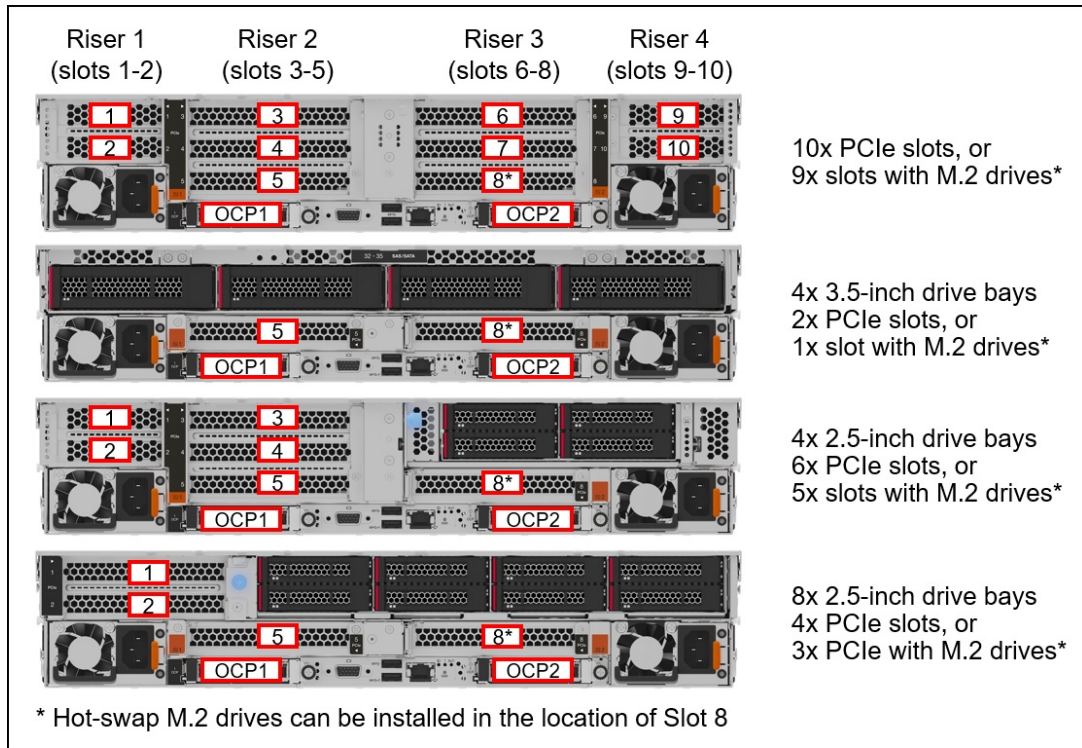

Figure 25. PCIe slots with rear drive bays

### Slot ordering information

In the SR650 V4, slots are configured one slot at a time, based on customer need for PCIe slots. This is different to prior generations, where slots were configured at the complete riser level, not the slot level.

The [DCSC configurator](#) includes a new slot configuration wizard which will automate the selection of slots and riser cages, based on the adapters and rear drive bays selected. The wizard includes a visual representation of where each adapter is to be placed.

The SR650 V4 uses a modular riser card design for Riser 2 and Riser 3, in that risers start with only 1 slot (slot 5 or slot 8) and can be configured with additional slots as needed. Additional slots can be configured CTO and built in the factory, or can be added as field upgrades after delivery. Slots 5 and 8 are connected to riser slots on the system board. The other slots (slots 4 & 3 for Riser 2 and slots 7 & 6 for Riser 3) are connected via cables to additional PCIe connectors on the system board. This "pay-as-you-go" design ensures that your server configuration only includes the adapter slots you need, thereby minimizing the cost of the overall server solution.

**Tip:** For Riser 2 and Riser 3, you do not need to select the lower slots before selecting upper slots. For example, you can select slots for Slot 3 and Slot 4, but leave Slot 5 empty.

The two slots in Riser 1 and Riser 4 are installed as a pair. Both must be selected and installed at the same time.

The following table lists the ordering information for the rear slots.

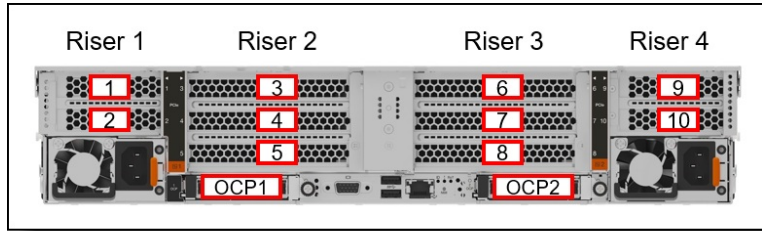

Figure 26. SR650 V4 rear slots

Table 63. Ordering information for rear slots

Part number	Feature	Description of feature code	Purpose
<b>Riser 1 (slots 1 &amp; 2)</b>			
4XH7B03717	C3S7	ThinkSystem 2U V4 2LP Riser Cage	Cage for Riser 1 or 4
4XH7B03718	C3R9	ThinkSystem SR650 V4 x8 Rear Riser Slot 1	Riser for Slot 1, x8
4XH7B03718	C4U8	ThinkSystem SR650 V4 x8 Rear Riser Slot 2	Riser for Slot 2, x8
<b>Riser 1 (slots 1 &amp; 2) for use with 8x2.5-inch drive bays</b>			
4XH7B03848*	C3RY	ThinkSystem 2U SR650 V4 2FH Riser Cage (Rear 8x25 HDD Cage)	Cage for Riser 1 for use with 8x2.5-inch drive bays
4X97B02316	C4TW	ThinkSystem SR650 V4 x8 Rear Riser Slot 1 w/ Rear 8x2.5" BP	Riser for Slot 1, x8
4X97B02318	C4TZ	ThinkSystem SR650 V4 x16 Rear Riser Slot 2 w/ Rear 8x2.5" BP	Riser for Slot 2, x16
<b>Riser 2 (slots 3, 4, 5)</b>			
4XH7B03839	C3S5	ThinkSystem 2U V4 3FH Riser Cage	Cage for Riser 2 or 3 without drive bays
4XH7B03719	C3S2	ThinkSystem 2U V4 1FH Riser Cage	Cage for Riser 2 or 3 for use with all rear drive bays
4X97B02316	C3R4	ThinkSystem SR650/a V4 x8 Rear Riser Slot 3	Riser for Slot 3, x8
4X97B02319	C3R8	ThinkSystem SR650/a V4 x16 Rear Riser Slot 3	Riser for Slot 3, x16
4X97B02318	C3R3	ThinkSystem SR650/a V4 x16 Rear Riser Slot 4	Riser for Slot 4, x16, 75W
4X97B02317	C3R7	ThinkSystem SR650/a V4 x16 High Watts Rear Riser Slot 4	Riser for Slot 4, x16, >75W
4XH7B02315	C62D	ThinkSystem SR650/a V4 x16 Rear Direct Riser Slot 5	Riser for Slot 5, x16, 75W
CTO only	C62E	ThinkSystem SR650 V4 x16 Rear Direct Riser Slot 5 for CPU+MEM Liquid Cooling	Riser for Slot 5, x16, 75W for Compute Complex Neptune water cooling (machine type 7DK2)
<b>Riser 3 (slots 6, 7, 8)</b>			
4XH7B03839	C3S5	ThinkSystem 2U V4 3FH Riser Cage	Cage for Riser 2 or 3 without drive bays
4XH7B03719	C3S2	ThinkSystem 2U V4 1FH Riser Cage	Cage for Riser 2 or 3 for use with all rear drive bays
4X97B02316	C4TX	ThinkSystem SR650/a V4 x8 Rear Riser Slot 6	Riser for Slot 6, x8
4X97B02319	C4U9	ThinkSystem SR650/a V4 x16 Rear Riser Slot 6	Riser for Slot 6, x16
4X97B02318	C4TV	ThinkSystem SR650/a V4 x16 Rear Riser Slot 7	Riser for Slot 7, x16, 75W
4X97B02317	C4UA	ThinkSystem SR650/a V4 x16 High Watts Rear Riser Slot 7	Riser for Slot 7, x16, >75W
4XH7B02315	C4U0	ThinkSystem SR650/a V4 x16 Rear Direct Riser Slot 8	Riser for Slot 8, 16
<b>Riser 4 (slots 9, 10)</b>			

Part number	Feature	Description of feature code	Purpose
4XH7B03717	C3S7	ThinkSystem 2U V4 2LP Riser Cage	Cage for Riser 1 or 4
4XH7B03718	C4U7	ThinkSystem SR650 V4 x8 Rear Riser Slot 9	Riser for Slot 9, x8
4XH7B03718	C4U6	ThinkSystem SR650 V4 x8 Rear Riser Slot 10	Riser for Slot 10, x8
OCP cable			
4X97A97300	C1YK	ThinkSystem SR650 V4/SR630 V4 x16 OCP Cable Kit	With this cable, an OCP slot is PCIe x16. Without this cable, the OCP slot is PCIe x8. 1 per OCP slot.

\* 4XH7B03848 also includes backplane and cage for 8x2.5-inch SAS/SATA drive bays

### Slot configurations

The following table lists the slot combinations that are supported for each drive configuration. The locations of the risers and slots is shown in the following figure.

**Tip:** The configuration numbers match the storage configurations listed in the [Storage configurations](#) section.

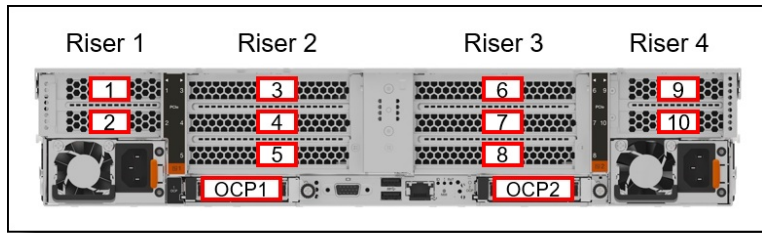

Figure 27. SR650 V4 rear slots

Table 64. Slot configurations ("- " means the slot is not available)

Cfg	CPU cooling				Front drive bays				Mid bays		Rear drive bays				Riser 1 slots		Riser 2 slots					Riser 3 slots				Riser 4 slots		OCP slots		
	CPUs	Air cooled	Open loop	CPUs+Mem	SAS/SATA	AnyBay	NVMe	E3.S 1T	E3.S 2T	2.5" SAS/SATA	2.5" NVMe	3.5" SAS/SATA	2.5" SAS/SATA	2.5" NVMe	2.5" AnyBay	PCIe slot count	1	2	3	4	5	6	7	8	9	10	1	2		
																													8	0
1-1	1-2	Y	Y	N	8	0	0	0	0	0	0	0	0	0	0	10	x8	x8	x8	x16	x16	x8	x16	x16	x8	x8	x8	x8	x8*	x16
1-2	1-2	Y	Y	N	8	0	0	0	0	0	0	0	0	0	0	10	x8	x8	x8	x16	x16	x8	x16	x16	x8	x8	x8	x8*	x16	
1-3	2	Y	Y	N	8	0	0	0	0	0	0	0	0	0	0	10	x8	x8	x8	x16	x16	x8	x16	x16	x8	x8	x8	x8*	x16	
1-4	1	Y	Y	N	8	0	0	0	0	0	0	0	0	0	0	5	x8	x8	x8	x16	x16	-	-	-	-	-	-	x8*	-	
2-1	2	Y	Y	N	0	0	8	0	0	0	0	0	0	0	0	10	x8	x8	x8	x16	x16	x8	x16	x16	x8	x8	x8*	x16		
2-2	1	Y	Y	N	0	0	8	0	0	0	0	0	0	0	0	3	-	-	x8	x16	x16	-	-	-	-	-	-	x8*	-	
3-1	2	Y	Y	N	0	8	0	0	0	0	0	0	0	0	0	10	x8	x8	x8	x16	x16	x8	x16	x16	x8	x8	x8*	x16		
3-2	2	Y	Y	N	0	8	0	0	0	0	0	0	0	0	0	10	x8	x8	x8	x16	x16	x8	x16	x16	x8	x8	x8*	x16		
3-3	2	Y	Y	N	0	8	0	0	0	0	0	0	0	0	0	9	x8	x8	x8	x16	x16	x8	x16	x16	x8	-	x8*	x16		
3-4	1	Y	Y	N	0	8	0	0	0	0	0	0	0	0	0	3	-	-	x8	x16	x16	-	-	-	-	-	x8*	-		
3-5	1	Y	Y	N	0	8	0	0	0	0	0	0	0	0	0	3	-	-	x8	x16	x16	-	-	-	-	-	x8*	-		

Cfg	CPU cooling				Front drive bays	Mid bays	Rear drive bays					Riser 1 slots	Riser 2 slots					Riser 3 slots					Riser 4 slots		OCP slots			
	CPU1	Air cooled	Open loop CPUs	Open loop CPUs+Mem			SAS/SATA	AnyBay	NVMe	E3.S 1T	E3.S 2T		2.5" SAS/SATA	2.5" NVMe	3.5" SAS/SATA	2.5" SAS/SATA	2.5" NVMe	2.5" AnyBay	PCIe slot count	1	2	3	4	5	6	7	8	9
3-6	1	Y	Y	N											2	-	-	-	x16	x16	-	-	-	-	-	-	x8	-
5-1	1-2	Y	Y	N	0	8	0	0	0	0	0	0	0	0	10	x8	x8	x8	x16	x16	x8	x16	x16	x8	x8	x8*	x16	
5-2	2	Y	Y	N											10	x8	x8	x8	x16	x16	x8	x16	x16	x8	x8	x8*	x16	
5-3	1	Y	Y	N											5	x8	x8	x8	x16	x16	-	-	-	-	-	x8*	-	
6-1	1-2	Y	Y	N	16	0	0	0	0	0	0	0	0	0	9	x8	x8	x8	x16	x16	x8	x16	-	x8	x8	x8*	x16	
6-2	1-2	Y	Y	N											9	x8	x8	x8	x16	x16	x8	x16	-	x8	x8	x8*	x16	
6-3	1-2	Y	Y	N											9	x8	x8	x8	x16	x16	x8	x16	-	x8	x8	x8*	x16	
6-4	1-2	Y	Y	N											9	x8	x8	x8	x16	x16	x8	x16	-	x8	x8	x8*	x16	
6-5	2	Y	Y	N											9	x8	x8	x8	x16	x16	x8	x16	-	x8	x8	x8*	x16	
6-6	1	Y	Y	N											5	x8	x8	x8	x16	x16	-	-	-	-	-	x8*	-	
7-1	2	Y	Y	N	0	0	16	0	0	0	0	0	0	0	6	-	-	x8	x16	x16	x8	x16	x16	-	-	x8*	x16	
7-2	1	Y	Y	N											1	-	-	x8	-	-	-	-	-	-	-	x8*	-	
8-1	2	Y	Y	N	0	8	8	0	0	0	0	0	0	0	6	-	-	x8	x16	x16	x8	x16	x16	-	-	x8*	x16	
8-2	2	Y	Y	N											6	-	-	x8	x16	x16	x8	x16	x16	-	-	x8*	x16	
8-3	2	Y	Y	N											5	-	-	x8	x16	x16	-	x16	x16	-	-	x8*	x16	
8-4	1	Y	Y	N											1	-	-	x8	-	-	-	-	-	-	-	x8*	-	
8-5	1	Y	Y	N											1	-	-	x8	-	-	-	-	-	-	-	x8*	-	
8-6	1	Y	Y	N											0	-	-	-	-	-	-	-	-	-	-	x8	-	
9-1	2	Y	Y	N	8	8	0	0	0	0	0	0	0	0	10	x8	x8	x8	x16	x16	x8	x16	x16	x8	x8	x8*	x16	
9-2	2	Y	Y	N											10	x8	x8	x8	x16	x16	x8	x16	x16	x8	x8	x8*	x16	
9-3	2	Y	Y	N											10	x8	x8	x8	x16	x16	x8	x16	x16	x8	x8	x8*	x16	
9-4	2	Y	Y	N											10	x8	x8	x8	x16	x16	x8	x16	x16	x8	x8	x8*	x16	
9-5	2	Y	Y	N											9	x8	x8	x8	x16	x16	x8	x16	x16	x8	-	x8*	x16	
9-6	1	Y	Y	N											3	-	-	x8	x16	x16	-	-	-	-	-	x8*	-	
9-7	1	Y	Y	N											3	-	-	x8	x16	x16	-	-	-	-	-	x8*	-	
9-8	1	Y	Y	N											3	-	-	x8	x16	x16	-	-	-	-	-	x8*	-	
9-9	1	Y	Y	N											3	-	-	x8	x16	x16	-	-	-	-	-	x8*	-	
9-10	1	Y	Y	N											2	-	-	-	x16	x16	-	-	-	-	-	x8	-	
10-1	2	Y	Y	N	8	0	8	0	0	0	0	0	0	0	10	x8	x8	x8	x16	x16	x8	x16	x16	x8	x8	x8*	x16	
10-2	2	Y	Y	N											10	x8	x8	x8	x16	x16	x8	x16	x16	x8	x8	x8*	x16	
10-3	2	Y	Y	N											9	x8	x8	x8	x16	x16	x8	x16	x16	x8	-	x8*	x16	
10-4	1	Y	Y	N											3	-	-	x8	x16	x16	-	-	-	-	-	x8*	-	
10-5	1	Y	Y	N											3	-	-	x8	x16	x16	-	-	-	-	-	x8*	-	
10-6	1	Y	Y	N											2	-	-	-	x16	x16	-	-	-	-	-	x8	-	
11-1	1-2	Y	Y	N	0	16	0	0	0	0	0	0	0	0	10	x8	x8	x8	x16	x16	x8	x16	x16	x8	x8	x8*	x16	
11-2	1-2	Y	Y	N											10	x8	x8	x8	x16	x16	x8	x16	x16	x8	x8	x8*	x16	
11-3	2	Y	Y	N											10	x8	x8	x8	x16	x16	x8	x16	x16	x8	x8	x8*	x16	
11-4	1	Y	Y	N											5	x8	x8	x8	x16	x16	-	-	-	-	-	x8*	-	
12-1	1-2	Y	Y	N	24	0	0	0	0	0	0	0	0	0	10	x8	x8	x8	x16	x16	x8	x16	x16	x8	x8	x8*	x16	
12-2	1-2	Y	Y	N											10	x8	x8	x8	x16	x16	x8	x16	x16	x8	x8	x8*	x16	

Cfg	CPU cooling				Front drive bays	Mid bays	Rear drive bays					Riser 1 slots	Riser 2 slots					Riser 3 slots					Riser 4 slots		OCP slots		
	CPUs	Air cooled	Open loop CPUs	Open loop CPUs+Mem			SAS/SATA	AnyBay	NVMe	E3.S 1T	E3.S 2T		2.5" SAS/SATA	2.5" NVMe	3.5" SAS/SATA	2.5" SAS/SATA	2.5" NVMe	2.5" AnyBay	PCIe slot count	1	2	3	4	5	6	7	8
12-3	1-2	Y	Y	N											10	x8	x8	x8	x16	x16	x8	x16	x16	x8	x8	x8*	x16
12-4	1-2	Y	Y	N											10	x8	x8	x8	x16	x16	x8	x16	x16	x8	x8	x8*	x16
12-5	2	Y	Y	N											10	x8	x8	x8	x16	x16	x8	x16	x16	x8	x8	x8*	x16
12-6	1	Y	Y	N											5	x8	x8	x8	x16	x16	-	-	-	-	-	x8*	-
13-1	2	Y	Y	N	0	0	24	0	0	0	0	0	0	0	4	-	-	x8	-	x16	x8	-	x16	-	-	x8*	x16
13-2	2	Y	Y	N											4	-	-	x8	x16	-	x8	x16	-	-	-	x8*	x16
14-1	2	Y	Y	N	16	8	0	0	0	0	0	0	0	0	10	x8	x8	x8	x16	x16	x8	x16	x16	x8	x8	x8*	x16
14-2	2	Y	Y	N											10	x8	x8	x8	x16	x16	x8	x16	x16	x8	x8	x8*	x16
14-3	2	Y	Y	N											10	x8	x8	x8	x16	x16	x8	x16	x16	x8	x8	x8*	x16
14-4	2	Y	Y	N											10	x8	x8	x8	x16	x16	x8	x16	x16	x8	x8	x8*	x16
14-5	2	Y	Y	N											9	x8	x8	x8	x16	x16	x8	x16	x16	x8	-	x8*	x16
14-6	1	Y	Y	N											3	-	-	x8	x16	x16	-	-	-	-	-	x8*	-
14-7	1	Y	Y	N											3	-	-	x8	x16	x16	-	-	-	-	-	x8*	-
14-8	1	Y	Y	N											3	-	-	x8	x16	x16	-	-	-	-	-	x8*	-
14-9	1	Y	Y	N											3	-	-	x8	x16	x16	-	-	-	-	-	x8*	-
14-10	1	Y	Y	N											2	-	-	-	x16	x16	-	-	-	-	-	x8	-
15-1	2	Y	Y	N	16	0	8	0	0	0	0	0	0	0	10	x8	x8	x8	x16	x16	x8	x16	x16	x8	x8	x8*	x16
15-2	2	Y	Y	N											10	x8	x8	x8	x16	x16	x8	x16	x16	x8	x8	x8*	x16
15-3	2	Y	Y	N											10	x8	x8	x8	x16	x16	x8	x16	x16	x8	x8	x8*	x16
15-4	2	Y	Y	N											10	x8	x8	x8	x16	x16	x8	x16	x16	x8	x8	x8*	x16
15-5	2	Y	Y	N											9	x8	x8	x8	x16	x16	x8	x16	x16	x8	-	x8*	x16
15-6	1	Y	Y	N											3	-	-	x8	x16	x16	-	-	-	-	-	x8*	-
15-7	1	Y	Y	N											3	-	-	x8	x16	x16	-	-	-	-	-	x8*	-
15-8	1	Y	Y	N											3	-	-	x8	x16	x16	-	-	-	-	-	x8*	-
15-9	1	Y	Y	N											3	-	-	x8	x16	x16	-	-	-	-	-	x8*	-
15-10	1	Y	Y	N											2	-	-	-	x16	x16	-	-	-	-	-	x8	-
16-1	1-2	Y	Y	N	0	24	0	0	0	0	0	0	0	0	10	x8	x8	x8	x16	x16	x8	x16	x16	x8	x8	x8*	x16
16-2	1-2	Y	Y	N											10	x8	x8	x8	x16	x16	x8	x16	x16	x8	x8	x8*	x16
16-3	2	Y	Y	N											10	x8	x8	x8	x16	x16	x8	x16	x16	x8	x8	x8*	x16
16-4	1	Y	Y	N											5	x8	x8	x8	x16	x16	-	-	-	-	-	x8*	-
17-3	1-2	Y	Y	N	24	0	0	0	0	0	0	0	4	0	5	x8	x8	x8	x16	x16	-	-	-	-	-	x8*	x16
17-4	1-2	Y	Y	N											5	x8	x8	x8	x16	x16	-	-	-	-	-	x8*	x16
17-5	1-2	Y	Y	N											5	x8	x8	x8	x16	x16	-	-	-	-	-	x8*	x16
17-6	1-2	Y	Y	N											5	x8	x8	x8	x16	x16	-	-	-	-	-	x8*	x16
17-7	2	Y	Y	N											5	x8	x8	x8	x16	x16	-	-	-	-	-	x8*	x16
17-8	2	Y	Y	N											5	x8	x8	x8	x16	x16	-	-	-	-	-	x8*	x16
17-9	1-2	Y	Y	N											5	x8	x8	x8	x16	x16	-	-	-	-	-	x8*	x16
17-10	1-2	Y	Y	N											5	x8	x8	x8	x16	x16	-	-	-	-	-	x8*	x16
17-11	2	Y	Y	N											5	x8	x8	x8	x16	x16	-	-	-	-	-	x8*	x16
17-12	1	Y	Y	N											5	x8	x8	x8	x16	x16	-	-	-	-	-	x8*	-

Cfg	CPUs	CPU cooling			Front drive bays	Mid bays	Rear drive bays					Riser 1 slots	Riser 2 slots					Riser 3 slots					Riser 4 slots		OCP slots			
		Air cooled	Open loop CPUs	Open loop CPUs+Mem			SAS/SATA	AnyBay	NVMe	E3.S 1T	E3.S 2T		2.5" SAS/SATA	2.5" NVMe	3.5" SAS/SATA	2.5" SAS/SATA	2.5" NVMe	2.5" AnyBay	PCIe slot count	1	2	3	4	5	6	7	8	9
17-13	1	Y	Y	N										5	x8	x8	x8	x16	x16	-	-	-	-	-	-	x8*	-	
17-14	1	Y	Y	N										5	x8	x8	x8	x16	x16	-	-	-	-	-	-	x8*	-	
18-3	2	Y	Y	N	24	0	0	0	0	0	0	0	0	4	6	x8	x8	x8	x16	x16	-	-	x16	-	-	x8*	x16	
18-4	2	Y	Y	N										6	x8	x8	x8	x16	x16	-	-	x16	-	-	x8*	x16		
18-5	2	Y	Y	N										6	x8	x8	x8	x16	x16	-	-	x16	-	-	x8*	x16		
18-6	2	Y	Y	N										6	x8	x8	x8	x16	x16	-	-	x16	-	-	x8*	x16		
18-7	2	Y	Y	N										6	x8	x8	x8	x16	x16	-	-	x16	-	-	x8*	x16		
18-8	2	Y	Y	N										6	x8	x8	x8	x16	x16	-	-	x16	-	-	x8*	x16		
19-3	2	Y	Y	N	16	8	0	0	0	0	0	0	4	0	0	6	x8	x8	x8	x16	x16	-	-	x16	-	-	x8*	x16
19-4	2	Y	Y	N										6	x8	x8	x8	x16	x16	-	-	x16	-	-	x8*	x16		
19-5	2	Y	Y	N										6	x8	x8	x8	x16	x16	-	-	x16	-	-	x8*	x16		
19-6	2	Y	Y	N										6	x8	x8	x8	x16	x16	-	-	x16	-	-	x8*	x16		
19-7	2	Y	Y	N										6	x8	x8	x8	x16	x16	-	-	x16	-	-	x8*	x16		
19-8	2	Y	Y	N										6	x8	x8	x8	x16	x16	-	-	x16	-	-	x8*	x16		
19-9	1	Y	Y	N										3	-	-	x8	x16	x16	-	-	-	-	-	x8*	-		
19-10	1	Y	Y	N										3	-	-	x8	x16	x16	-	-	-	-	-	x8*	-		
19-11	1	Y	Y	N										3	-	-	x8	x16	x16	-	-	-	-	-	x8*	-		
19-12	1	Y	Y	N										3	-	-	x8	x16	x16	-	-	-	-	-	x8*	-		
19-13	1	Y	Y	N										2	-	-	-	x16	x16	-	-	-	-	-	x8	-		
19-14	1	Y	Y	N										2	-	-	-	x16	x16	-	-	-	-	-	x8	-		
20-5	1-2	Y	Y	N	24	0	0	0	0	8	0	0	0	0	0	8	x8	-	x8	x16	x16	x8	x16	x16	x8	-	x8*	x16
20-6	1-2	Y	Y	N										8	x8	-	x8	x16	x16	x8	x16	x16	x8	-	x8*	x16		
20-9	1-2	Y	Y	N										8	x8	-	x8	x16	x16	x8	x16	x16	x8	-	x8*	x16		
20-10	1-2	Y	Y	N										8	x8	-	x8	x16	x16	x8	x16	x16	x8	-	x8*	x16		
20-11	2	Y	Y	N										8	x8	-	x8	x16	x16	x8	x16	x16	x8	-	x8*	x16		
20-12	1	Y	Y	N										4	x8	-	x8	x16	x16	-	-	-	-	-	x8*	-		
21-5	2	Y	Y	N	16	8	0	0	0	8	0	0	0	0	7	x8	-	x8	x16	x16	x8	x16	-	x8	-	x8*	x16	
21-6	2	Y	Y	N										7	x8	-	x8	x16	x16	x8	x16	-	x8	-	x8*	x16		
21-9	1	Y	Y	N										3	-	-	x8	x16	x16	-	-	-	-	-	x8*	-		
21-10	1	Y	Y	N										3	-	-	x8	x16	x16	-	-	-	-	-	x8*	-		
22-5	2	Y	Y	N	16	8	0	0	0	0	0	0	8	0	0	4	x8	x16	-	-	x16	-	-	x16	-	x8*	x16	
22-6	2	Y	Y	N										4	x8	x16	-	-	x16	-	-	x16	-	-	x8*	x16		
22-11	1	Y	Y	N										3	x8	x16	-	-	x16	-	-	-	-	-	x8*	-		
22-12	1	Y	Y	N										3	x8	x16	-	-	x16	-	-	-	-	-	x8*	-		
23-5	1-2	Y	Y	N	24	0	0	0	0	0	0	0	8	0	0	4	x8	x16	-	-	x16	-	-	x16	-	x8*	x16	
23-6	1-2	Y	Y	N										4	x8	x16	-	-	x16	-	-	x16	-	-	x8*	x16		
23-15	1-2	Y	Y	N										3	x8	x16	-	-	x16	-	-	-	-	-	x8*	x16		
23-16	1-2	Y	Y	N										3	x8	x16	-	-	x16	-	-	-	-	-	x8*	x16		
23-17	2	Y	Y	N										3	x8	x16	-	-	x16	-	-	-	-	-	x8*	x16		
23-18	1	Y	Y	N										3	x8	x16	-	-	x16	-	-	-	-	-	x8*	-		

Cfg	CPUs	CPU cooling			Front drive bays				Mid bays		Rear drive bays				PCIe slot count	Riser 1 slots		Riser 2 slots			Riser 3 slots			Riser 4 slots		OCP slots		
		Air cooled	Open loop CPUs	Open loop CPUs+Mem	SAS/SATA	AnyBay	NVMe	E3.S 1T	E3.S 2T	2.5" SAS/SATA	2.5" NVMe	3.5" SAS/SATA	2.5" SAS/SATA	2.5" NVMe		2.5" AnyBay	1	2	3	4	5	6	7	8	9	10	1	2
24-1	2	Y	Y	N	0	0	24	0	0	0	8	0	0	0	0	2	-	-	x8	-	-	-	-	x16	-	-	x8*	x8
25-1	2	Y	Y	N	0	0	24	0	0	0	8	0	0	4	0	1	-	-	x8	-	-	-	-	-	-	-	x8*	x8
26-1	1-2	Y	Y	N	24	0	0	0	0	8	0	0	4	0	0	5	x8	-	x8	x16	x16	-	-	x16	-	-	x8*	x16
26-2	1-2	Y	Y	N												5	x8	-	x8	x16	x16	-	-	x16	-	-	x8*	x16
26-3	2	Y	Y	N												5	x8	-	x8	x16	x16	-	-	x16	-	-	x8*	x16
26-4	1	Y	Y	N												4	x8	-	x8	x16	x16	-	-	-	-	-	x8*	-
27-1	1-2	Y	Y	N	24	0	0	0	0	8	0	0	8	0	0	4	x8	x16	-	-	x16	-	-	x16	-	-	x8*	x16
27-2	1-2	Y	Y	N												4	x8	x16	-	-	x16	-	-	x16	-	-	x8*	x16
27-3	2	Y	Y	N												4	x8	x16	-	-	x16	-	-	x16	-	-	x8*	x16
27-4	1	Y	Y	N												4	x8	x16	-	-	x16	-	-	x16	-	-	x8*	-
35-1	1-2	Y	Y	N	12	0	0	0	0	0	0	0	0	0	0	10	x8	x8	x8	x16	x16	x8	x16	x16	x8	x8	x8*	x16
35-2	1-2	Y	Y	N												10	x8	x8	x8	x16	x16	x8	x16	x16	x8	x8	x8*	x16
36-1	1-2	Y	Y	N	8	4	0	0	0	0	0	0	0	0	0	10	x8	x8	x8	x16	x16	x8	x16	x16	x8	x8	x8*	x16
36-2	1-2	Y	Y	N												10	x8	x8	x8	x16	x16	x8	x16	x16	x8	x8	x8*	x16
37-1	1-2	Y	Y	N	8	0	4	0	0	0	0	0	0	0	0	10	x8	x8	x8	x16	x16	x8	x16	x16	x8	x8	x8*	x16
37-2	1-2	Y	Y	N												10	x8	x8	x8	x16	x16	x8	x16	x16	x8	x8	x8*	x16
38-1	1-2	Y	Y	N	12	0	0	0	0	0	0	4	0	0	0	2	-	-	-	-	x16	-	-	x16	-	-	x8*	x16
38-2	1-2	Y	Y	N												2	-	-	-	-	x16	-	-	x16	-	-	x8*	x16
41-1	2	Y	Y	N	12	0	0	0	0	0	0	0	0	0	4	6	x8	x8	x16	x16	x16	-	-	x16	-	-	x8*	x16
41-2	2	Y	Y	N												6	x8	x8	x16	x16	x16	-	-	x16	-	-	x8*	x16
42-1	2	Y	Y	N	12	0	0	0	0	0	8	0	0	0	0	7	x8	-	x8	x16	-	x16	x16	x16	x8	-	x8*	x8
42-2	2	Y	Y	N												7	x8	-	x8	x16	-	x16	x16	x16	x8	-	x8*	x8
59-1	2	Y	Y	N	0	0	0	8	0	0	0	0	0	0	0	10	x8	x8	x8	x16	x16	x8	x16	x16	x8	x8	x8*	x16
59-2	1	Y	Y	N												3	-	-	x8	x16	x16	-	-	-	-	-	x8*	-
60-1	2	Y	Y	N	0	0	0	16	0	0	0	0	0	0	0	6	-	-	x8	x16	x16	x8	x16	x16	-	-	x8*	x16
60-2	1	Y	Y	N												1	-	-	x8	-	-	-	-	-	-	-	x8*	-
61-1	2	Y	Y	N	0	0	0	24	0	0	0	0	0	0	0	4	-	-	x8	-	x16	x8	-	x16	-	-	x8*	x16
62-1	2	Y	Y	N	0	0	0	32	0	0	0	0	0	0	0	2	-	-	x8	-	-	x8	-	-	-	-	x8*	x16
63-1	2	Y	Y	N	0	0	0	0	4	0	0	0	0	0	0	10	x8	x8	x8	x16	x16	x8	x16	x16	x8	x8	x8*	x16
63-2	1	Y	Y	N												3	-	-	x8	x16	x16	-	-	-	-	-	x8*	-
64-1	2	Y	Y	N	0	0	0	0	8	0	0	0	0	0	0	6	-	-	x8	x16	x16	x8	x16	x16	-	-	x8*	x16
65-1	2	Y	Y	N	0	0	0	0	12	0	0	0	0	0	0	4	-	-	x8	-	x16	x8	-	x16	-	-	x8*	x16
66-1	1	Y	Y	N	0	0	0	4	2	0	0	0	0	0	0	3	-	-	x8	x16	x16	-	-	-	-	-	-	-
67-1	2	Y	Y	N	0	0	0	8	4	0	0	0	0	0	0	6	-	-	x8	x16	x16	x8	x16	x16	-	-	x8*	x16
67-2	1	Y	Y	N												1	-	-	x8	-	-	-	-	-	-	-	-	-
68-1	2	Y	Y	N	0	0	0	8	8	0	0	0	0	0	0	4	-	-	x8	-	x16	x8	-	x16	-	-	x8*	x16
69-1	2	Y	Y	N	0	0	0	8	12	0	0	0	0	0	0	2	-	-	x8	-	-	x8	-	-	-	-	x8*	x16
70-1	2	Y	Y	N	0	0	0	16	4	0	0	0	0	0	0	4	-	-	x8	-	x16	x8	-	x16	-	-	x8*	x16
71-1	2	Y	Y	N	0	0	0	16	8	0	0	0	0	0	0	2	-	-	x8	-	-	x8	-	-	-	-	x8*	x16
72-1	2	Y	Y	N	0	0	0	24	4	0	0	0	0	0	0	2	-	-	x8	-	-	x8	-	-	-	-	x8*	x16

Cfg	CPU cooling				Front drive bays					Mid bays		Rear drive bays					Riser 1 slots		Riser 2 slots			Riser 3 slots			Riser 4 slots		OCP slots	
	CPUs	Air cooled	Open loop CPUs	Open loop CPUs+Mem	SAS/SATA	AnyBay	NVMe	E3.S 1T	E3.S 2T	2.5" SAS/SATA	2.5" NVMe	3.5" SAS/SATA	2.5" SAS/SATA	2.5" NVMe	2.5" AnyBay	PCIe slot count	1	2	3	4	5	6	7	8	9	10	1	2
87-1	2	N	N	Y	0	0	8	0	0	0	0	0	0	0	0	5	-	-	x8	x16	x16	x8	-	x16	-	-	x8*	x8
88-1	2	N	N	Y	0	8	0	0	0	0	0	0	0	0	0	5	-	-	x8	x16	x16	x8	-	x16	-	-	x8*	x8
88-2	2	N	N	Y												5	-	-	x8	x16	x16	x8	-	x16	-	-	x8*	x8
88-3	2	N	N	Y												4	-	-	x8	x16	x16	-	-	x16	-	-	x8*	x8
89-1	2	N	N	Y	0	0	16	0	0	0	0	0	0	0	0	3	-	-	x8	-	x16	x8	-	-	-	-	x8*	x8
90-1	2	N	N	Y	0	8	8	0	0	0	0	0	0	0	0	3	-	-	x8	-	x16	x8	-	-	-	-	x8*	x8
90-2	2	N	N	Y												3	-	-	x8	-	x16	x8	-	-	-	-	x8*	x8
90-3	2	N	N	Y												2	-	-	x8	-	x16	-	-	-	-	-	x8*	x8
91-1	2	N	N	Y	8	8	0	0	0	0	0	0	0	0	0	5	-	-	x8	-	x16	x8	x16	x16	-	-	x8*	x8
91-2	2	N	N	Y												5	-	-	x8	-	x16	x8	x16	x16	-	-	x8*	x8
91-3	2	N	N	Y												5	-	-	x8	-	x16	x8	x16	x16	-	-	x8*	x8
91-4	2	N	N	Y												5	-	-	x8	-	x16	x8	x16	x16	-	-	x8*	x8
91-5	2	N	N	Y												4	-	-	x8	-	x16	-	x16	x16	-	-	x8*	x8
92-1	2	N	N	Y	8	0	8	0	0	0	0	0	0	0	0	5	-	-	x8	-	x16	x8	x16	x16	-	-	x8*	x8
92-2	2	N	N	Y												5	-	-	x8	-	x16	x8	x16	x16	-	-	x8*	x8
92-3	2	N	N	Y												4	-	-	x8	-	x16	-	x16	x16	-	-	x8*	x8
97-1	2	N	N	Y	0	0	0	8	0	0	0	0	0	0	0	6	x8	-	x8	-	x16	x8	-	x16	x8	-	x8*	x8
98-1	2	N	N	Y	0	0	0	16	0	0	0	0	0	0	0	4	x8	-	x8	-	-	x8	-	-	x8	-	x8*	x8
101-1	2	Y	Y	N	0	0	24	0	0	0	0	0	0	4	0	2	-	-	x8	-	x16	-	-	-	-	-	x8*	x16
102-1	1	Y	Y	N	0	0	0	0	4	0	0	0	0	0	0	5	x8	x8	x8	x16	x16	-	-	-	-	-	x8*	-
103-1	2	N	N	Y	8	0	0	0	0	0	0	0	0	0	0	8	x8	-	x8	x16	x16	x8	x16	x16	x8	-	x8*	x8
103-2	2	N	N	Y												8	x8	-	x8	x16	x16	x8	x16	x16	x8	-	x8*	x8
103-3	2	N	N	Y												7	x8	-	x8	x16	x16	x8	x16	x16	-	-	x8*	x8
104-1	2	N	N	Y	0	8	0	0	0	0	0	0	0	0	0	8	x8	-	x8	x16	x16	x8	x16	x16	x8	-	x8*	x8
104-2	2	N	N	Y												7	x8	-	x8	x16	x16	x8	x16	x16	-	-	x8*	x8
105-1	2	N	N	Y	16	0	0	0	0	0	0	0	0	0	0	8	x8	-	x8	x16	x16	x8	x16	x16	x8	-	x8*	x8
105-2	2	N	N	Y												8	x8	-	x8	x16	x16	x8	x16	x16	x8	-	x8*	x8
105-3	2	N	N	Y												8	x8	-	x8	x16	x16	x8	x16	x16	x8	-	x8*	x8
105-4	2	N	N	Y												8	x8	-	x8	x16	x16	x8	x16	x16	x8	-	x8*	x8
105-5	2	N	N	Y												7	x8	-	x8	x16	x16	x8	x16	x16	-	-	x8*	x8
106-1	2	N	N	Y	0	16	0	0	0	0	0	0	0	0	0	8	x8	-	x8	x16	x16	x8	x16	x16	x8	-	x8*	x8
106-2	2	N	N	Y												8	x8	-	x8	x16	x16	x8	x16	x16	x8	-	x8*	x8
106-3	2	N	N	Y												7	x8	-	x8	x16	x16	x8	x16	x16	-	-	x8*	x8
117-1	1-2	Y	Y	N	8	0	0	0	0	0	0	0	0	0	0	10	x8	x8	x8	x16	x16	x8	x16	x16	x8	x8	x8*	x16
117-2	1-2	Y	Y	N												10	x8	x8	x8	x16	x16	x8	x16	x16	x8	x8	x8*	x16
118-1	2	Y	Y	N	12	0	0	0	0	0	0	0	0	4	0	6	x8	x8	x16	x16	x16	-	-	x16	-	-	x8*	x16
118-2	2	Y	Y	N												6	x8	x8	x16	x16	x16	-	-	x16	-	-	x8*	x16
119-1	1	Y	Y	N	0	0	0	0	6	0	0	0	0	0	0	2	-	-	x8	-	x16	-	-	-	-	-	x8*	-
120-1	1	Y	Y	N	0	0	0	4	6	0	0	0	0	0	0	1	-	-	x8	-	-	-	-	-	-	-	x8*	-
121-1	2	Y	Y	N	0	8	8	0	0	0	0	0	0	0	0	6	-	-	x8	x16	x16	x8	x16	x16	-	-	x8*	x16

Cfg	CPUs	CPU cooling			Front drive bays				Mid bays		Rear drive bays			Riser 1 slots		Riser 2 slots			Riser 3 slots			Riser 4 slots		OCP slots				
		Air cooled	Open loop CPUs	Open loop CPUs+Mem	SAS/SATA	AnyBay	NVMe	E3.S 1T	E3.S 2T	2.5" SAS/SATA	2.5" NVMe	3.5" SAS/SATA	2.5" SAS/SATA	2.5" NVMe	2.5" AnyBay	PCIe slot count	1	2	3	4	5	6	7	8	9	10	1	2
121-2	2	Y	Y	N											6	-	-	x8	x16	x16	x8	x16	x16	-	-	x8*	x16	
121-3	2	Y	Y	N											5	-	-	x8	x16	x16	-	x16	x16	-	-	x8*	x16	
121-4	1	Y	Y	N											1	-	-	x8	-	-	-	-	-	-	-	x8*	-	
121-5	1	Y	Y	N											1	-	-	x8	-	-	-	-	-	-	-	x8*	-	
121-6	1	Y	Y	N											0	-	-	-	-	-	-	-	-	-	-	x8	-	
122-1	2	Y	Y	N	8	4	0	0	0	0	0	0	0	4	0	6	x8	x8	x8	x16	x16	-	-	x16	-	-	x8*	x16
122-2	2	Y	Y	N											6	x8	x8	x8	x16	x16	-	-	x16	-	-	x8*	x16	

\* OCP slot 1 can be configured as x16 if slot 3 is not configured

### Slot field upgrades

Slot configurations can also be ordered as field upgrades using option part numbers, as listed in the following table.

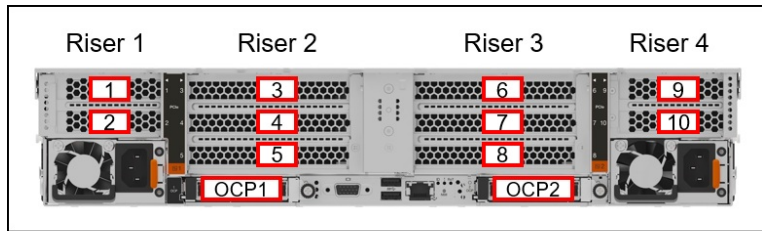

Figure 28. SR650 V4 rear slots

Table 65. Slot field upgrades

Part number	Description	Contents & purpose	Max Qty
<b>Riser 1 (slots 1 &amp; 2) or Riser 4 (slots 9, 10)</b>			
4XH7B03718	ThinkSystem SR650 V4 x8 PCIe Gen5 Cable Riser for Slot 1/2/9/10 Option Kit	Riser with x8 slot for use in slot 1, 2, 9, or 10	4
4XH7B03717	ThinkSystem SR650 V4 Riser Cage for Riser 1 or 4 Option Kit	Cage for Riser 1 or Riser 4 (2x LP slot cage)	1
<b>Riser 1 (slots 1 &amp; 2) only for use with 8x2.5-inch drive bays</b>			
4X97B02316	ThinkSystem SR650/a V4 x8 Gen5 Cable Riser Slot 3 & 6 Option Kit	Riser with x8 slot for use in slot 1	1
4X97B02318	ThinkSystem SR650/a V4 x16 Gen5 Cable Riser Slot 4 & 7 Option Kit	Riser with x16 slot for use in slot 2	1
4XH7B03848	ThinkSystem SR650 V4 8x2.5" SAS/SATA Rear Backplane option Kit	Cage for Riser 1 with 2 full-height slots Backplane & cage for 8x2.5-inch SAS/SATA drives	1
<b>Riser 2 (slots 3, 4, 5) or Riser 3 (slots 6, 7, 8)</b>			
4XH7B03719	ThinkSystem SR650 V4 Riser Cage for Riser 2 or 3 w/ Rear Backplane	Cage for Riser 2 or 3 for use with any rear drive bays	2
4XH7B03839	ThinkSystem SR650/a V4 Riser Cage for Riser 2 or 3 w/ 3x PCIe Slots installation	Cage for Riser 2 or 3 without any rear drive bays	2
4X97B02316	ThinkSystem SR650/a V4 x8 Gen5 Cable Riser Slot 3 & 6 Option Kit	Riser with x8 slot for Slot 3 or 6, 75W max	2
4X97B02319	ThinkSystem SR650/a V4 x16 Gen5 High Power Cable Riser Slot 3 & 6 Option Kit	Riser with x16 slot for Slot 3 or 6, >75W	2
4X97B02318	ThinkSystem SR650/a V4 x16 Gen5 Cable Riser Slot 4 & 7 Option Kit	Riser with x16 slot for Slot 4 or 7, 75W max	2
4X97B02317	ThinkSystem SR650/a V4 x16 Gen5 High Power Cable Riser Slot 4 & 7 Option Kit	Riser with x16 slot for Slot 4 or 7, >75W	2
4XH7B02315	ThinkSystem SR650/a V4 x16 Gen5 Rigid Riser Slot 5 & 8 Option Kit	Riser with x16 slot for Slot 5 or 8, 75W max	2
4XH7B04304	ThinkSystem SR650 V4 x16 Gen5 Rigid Riser Option Kit for CPU+MEM Direct Water Cooling (planned for June 2025)	Riser with x16 slot for Slot 8, 75W for use with Compute Complex Neptune Core liquid cooling	1
<b>OCP slots</b>			
4X97A97300	ThinkSystem V4 1U/2U OCP x16 Enablement Cable Kit	With this cable, an OCP slot is PCIe x16. Without this cable, the OCP slot is PCIe x8. 1 per OCP slot.	2

### OCP slot filler

If customers or partners remove an OCP adapter from the server, we recommend that a slot cover (slot filler) be installed in its place to ensure proper airflow in the server. Ordering information is listed in the following table.

**Tip:** For CTO orders and preconfigured models, slot fillers are automatically installed in slots where an OCP adapter is not installed.

Table 66. OCP slot filler

Part number	Description
4XF7B06188	ThinkSystem OCP3 FILLER

### Serial port

The SR650 V4 optionally supports a RS-232 serial port by adding a COM port bracket to either slot 5 or slot 8. Ordering information is shown in the following table.

Table 67. Serial port

Part number	Feature code	Description
4X97A97253	C3FB	ThinkSystem V4 1U/2U COM Port Upgrade Kit

The bracket is shown in the following figure. The option part number includes both Low Profile and Full Height brackets.

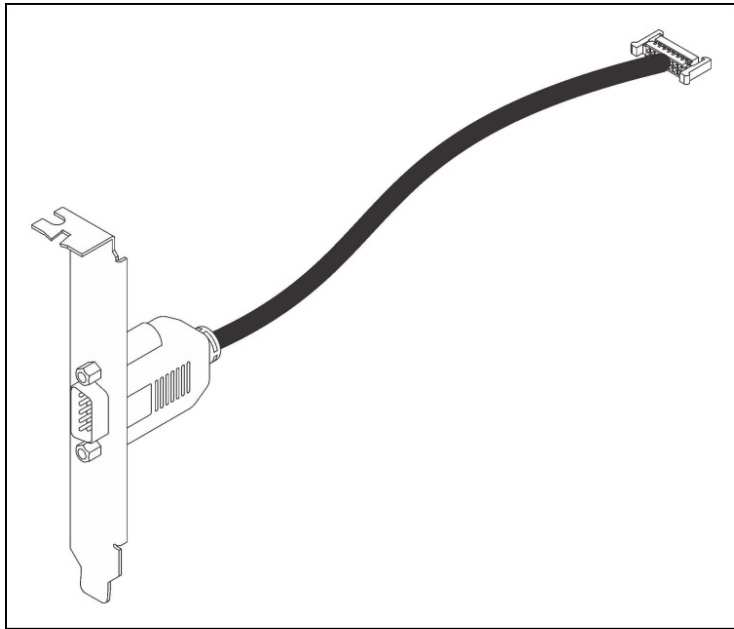

Figure 29. ThinkSystem V4 1U/2U COM Port Upgrade Kit

### Network adapters

This section lists the supported network adapters:

- [OCP network adapters](#)
- [PCIe network adapters](#)
- [Adapters with Generic firmware](#)

#### OCP network adapters

The server has two dedicated OCP 3.0 SFF slots each with either a PCIe x8 or x16 host interface. The OCP slots are both located at the rear of the server. See [Figure 3](#) for the location of the OCP slots.

The following table lists the supported OCP adapters. One port can optionally be shared with the XCC management processor for Wake-on-LAN and NC-SI support.

Table 68. Supported OCP adapters

Part number	Feature code	Description	Maximum supported	PCIe width
<b>Gigabit Ethernet</b>				
4XC7A08235	B5T1	ThinkSystem Broadcom 5719 1GbE RJ45 4-port OCP Ethernet Adapter	2	PCIe x4
4XC7A96731	C4HR	ThinkSystem Intel E610-T4 1GBase-T 4-Port OCP Ethernet Adapter(Generic FW)*	2	PCIe x8
<b>10 Gb Ethernet - 10GBASE-T</b>				
4XC7A95696	C4GB	ThinkSystem Broadcom 57412 10GBase-T 4-Port OCP Ethernet Adapter	2	PCIe x8
4XC7A08236	B5ST	ThinkSystem Broadcom 57416 10GBASE-T 2-port OCP Ethernet Adapter	2	PCIe x8
4XC7A96732	C4HS	ThinkSystem Intel E610-T2 10GBase-T 2-Port OCP Ethernet Adapter(Generic FW)*	2	PCIe x4
4XC7A96734	C4HU	ThinkSystem Intel E610-T4 10GBase-T 4-Port OCP Ethernet Adapter(Generic FW)*	2	PCIe x4
<b>25 Gb Ethernet</b>				
4XC7A08237	BN2T	ThinkSystem Broadcom 57414 10/25GbE SFP28 2-Port OCP Ethernet Adapter	2	PCIe x8
4XC7A80567	BPPW	ThinkSystem Broadcom 57504 10/25GbE SFP28 4-Port OCP Ethernet Adapter	2	PCIe x16†
4XC7A62582	BE4T	ThinkSystem Mellanox ConnectX-6 Lx 10/25GbE SFP28 2-port OCP Ethernet Adapter	2	PCIe x8
<b>100 Gb Ethernet</b>				
4XC7A08243	BPPX	ThinkSystem Broadcom 57508 100GbE QSFP56 2-Port OCP Ethernet Adapter	2	PCIe x16†
4XC7A99190	C62H	ThinkSystem Nvidia ConnectX-6 Dx 100GbE QSFP56 2-port OCP Ethernet Adapter(Generic)*	2	PCIe x16†
<b>400 Gb Ethernet</b>				
4XC7A95695	C4CQ	ThinkSystem Broadcom 57608 2x200/1x400GbE QSFP112 OCP Ethernet Adapter(Generic FW)*	2	PCIe x16†

\* See the [Adapters with Generic firmware](#) section

† OCP x16 enablement cable required; see below

The table above indicates the PCIe width of host interface for each adapter. All adapters with a PCIe x16 interface will require that the OCP slots have a x16 connection, using the cable kit listed in the following table.

Table 69. ThinkSystem V4 1U/2U OCP x16 Enablement Cable Kit

Part number	Feature code	Description
4X97A97300	C1YK	ThinkSystem V4 1U/2U OCP x16 Enablement Cable Kit

### PCIe network adapters

The following table lists additional supported network adapters that can be installed in the regular PCIe slots.

Table 70. Supported PCIe Network Adapters

Part number	Feature code	Description	Maximum supported	Slots	PCIe width
<b>Gigabit Ethernet</b>					
7ZT7A00484	AUZV	ThinkSystem Broadcom 5719 1GbE RJ45 4-Port PCIe Ethernet Adapter	10	1-10	PCIe x8
<b>10 Gb Ethernet - 10GBASE-T</b>					
4XC7A95697	C4GC	ThinkSystem Broadcom 57412 10GBase-T 4-Port PCIe Ethernet Adapter	4	3-8	PCIe x8
7ZT7A00496	AUKP	ThinkSystem Broadcom 57416 10GBASE-T 2-Port PCIe Ethernet Adapter	10	1-10	PCIe x8
<b>25 Gb Ethernet</b>					
4XC7A08238	BK1H	ThinkSystem Broadcom 57414 10/25GbE SFP28 2-port PCIe Ethernet Adapter	10	1-10	PCIe x8
4XC7A80566	BNWM	ThinkSystem Broadcom 57504 10/25GbE SFP28 4-port PCIe Ethernet Adapter	4	3-8	PCIe x16
4XC7A62580	BE4U	ThinkSystem Mellanox ConnectX-6 Lx 10/25GbE SFP28 2-port PCIe Ethernet Adapter	10	1-10	PCIe x8
4XC7A99191	C62J	ThinkSystem Nvidia ConnectX-7 10/25GbE SFP28 4-Port PCIe Ethernet Adapter(Generic)*	4	3-8	PCIe x16
<b>100 Gb Ethernet and HDR100 InfiniBand</b>					
4XC7A08297	BK1J	ThinkSystem Broadcom 57508 100GbE QSFP56 2-Port PCIe 4 Ethernet Adapter	4	3-8	PCIe x16
4XC7A08248	B8PP	ThinkSystem Mellanox ConnectX-6 Dx 100GbE QSFP56 2-port PCIe Ethernet Adapter	4	3-8	PCIe x16
<b>200 Gb Ethernet and HDR/NDR200 InfiniBand</b>					
4XC7A81883	BQBN	ThinkSystem NVIDIA ConnectX-7 NDR200/200GbE QSFP112 2-port PCIe Gen5 x16 Adapter	4	3-8	PCIe x16
4XC7A87752	BVBG	ThinkSystem NVIDIA BlueField-3 B3220 VPI QSFP112 2P 200G PCIe Gen5 x16 Adapter	2‡	3-8	PCIe x16
<b>400 Gb Ethernet and NDR InfiniBand</b>					
4XC7A95572	C4GA	ThinkSystem Broadcom 57608 2x200/1x400GbE QSFP112 PCIe Ethernet Adapter	4	3-8	PCIe x16
4XC7A95508	C51C	ThinkSystem NVIDIA ConnectX-7 NDR400 OSFP 1-port PCIe Gen5 VPI Adapter	4	3-8	PCIe x16
4XC7B03668	C9AQ	ThinkSystem NVIDIA ConnectX-8 8240 400GbE / 400Gb/s IB QSFP112 2-port PCIe Gen6 x16 (Generic FW)*	2‡	5,7	PCIe x16
<b>800 Gb XDR InfiniBand / 400 Gb Ethernet</b>					
4XC7B03667	C9AP	ThinkSystem NVIDIA ConnectX-8 8180 800Gbs XDR IB / 2x400GbE OSFP 1-port PCIe Gen6 x16 (Generic FW)*	2‡	5,7	PCIe x16

\* See the [Adapters with Generic firmware](#) section

‡ CX8 and B3220 adapters require additional cables; see below

The NVIDIA ConnectX-8 8240 adapter (2x 400Gb) and ConnectX-8 8180 adapter (1x 800Gb) both require the use of an Auxiliary cable which plugs into a second PCIe x16 connection. The combination of the x16 host interface of the adapter plus the x16 connection of the Auxiliary cable results in a PCIe 5.0 x32 connection, needed for 800 Gb networking connectivity. Ordering information for the Auxiliary cable is listed in the following table. For CTO orders, the cable is automatically selected when one of the ConnectX-8 is selected.

Table 71. Auxiliary cable needed for ConnectX-8 adapters

Part number	Feature code	Description
4X97B05994	C8WC	ThinkSystem 1U/2U V4 NVIDIA ConnectX-8 Aux Cable Kit

When adding ThinkSystem NVIDIA BlueField-3 B3220 VPI QSFP112 2P 200G PCIe Gen5 x16 Adapter (4XC7A87752) as a field upgrade, the power cable kit listed in the following table will also need to be ordered. For CTO orders, the appropriate cable is automatically selected when the adapter is selected, based on the slot the adapter is installed in.

Table 72. Power cable for BlueField-3 B3220 DPU

Part number	Feature code	Description
4X97B04861	C6R3 / C6R1	ThinkSystem SR650/a V4 DPU Adapter Power Cable Kit <ul style="list-style-type: none"> <li>• 1x 220mm power cable for adapters in slot 5, 8 (SBB7A95591, C6R3)</li> <li>• 1x 400mm power cable for adapters in slots 4, 6, 7 (SBB7A95592, C6R1)</li> </ul>

For more information, including the transceivers and cables that each adapter supports, see the list of Lenovo Press Product Guides in the Networking adapters category:  
<https://lenovopress.com/servers/options/ethernet>

### Adapters with Generic firmware

As indicated in the tables of supported adapters, some adapters are now offered by Lenovo with standard vendor firmware (look for "Generic FW" or "Generic" in the adapter names). These adapters are supported in Lenovo servers however there are currently limitations on the use of Lenovo management tools.

Support in Lenovo XClarity management tools for adapters with generic firmware is per the following table.

**Tip:** Always use firmware that is obtained from Lenovo sources to ensure the firmware is fully tested by Lenovo and is supported. You should not use firmware that is obtained from the vendor web site, unless directed to do so by Lenovo support.

Table 73. Lenovo XClarity management tools support for adapters with generic firmware

Function	Lenovo XClarity Provisioning Manager	Lenovo XClarity OneCLI (out-of-band)	Lenovo XClarity OneCLI (in-band)	Lenovo XClarity Administrator
Adapter configuration	Supported (in-band via UEFI)	Planned for support 3Q/2025	Planned for support 3Q/2025	Planned for support 3Q/2025

### GPU adapters

This section describes the supported GPUs.

- [GPU part numbers](#)
- [GPU configuration rules](#)
- [GPU Full Length Thermal Option Kit](#)
- [GPU cable kits](#)

**4x DW GPU support?** If you are looking for support for 4 double-wide GPUs with NVLink in a 2U rack form factor, consider the [ThinkSystem SR650a V4 server](#).

## GPU part numbers

The SR650 V4 supports the following graphics processing units (GPUs).

Table 74. Supported GPUs

Part number	Feature code	Description	Controlled GPU	Form factor	Aux power	Maximum supported	Slots supported
Single-wide GPUs							
4X67A84824	BS2C	ThinkSystem NVIDIA L4 24GB PCIe Gen4 Passive GPU	Controlled	LP	No	10	1-10
4X67A97287	C4S1	ThinkSystem NVIDIA RTX 4000 Ada 20GB PCIe Active GPU	No	FHFL	Yes	4	3,4,6,7
Double-wide GPUs							
4X67A89325	BXAK	ThinkSystem NVIDIA H100 NVL 94GB PCIe Gen5 Passive GPU	Controlled	FHFL	Yes	2	4,7*
4X67A90669	BYFH	ThinkSystem NVIDIA L40S 48GB PCIe Gen4 Passive GPU	Controlled	FHFL	Yes	2	4,7*
4X67A96491	C4RX	ThinkSystem NVIDIA RTX 4500 Ada 24GB PCIe Active GPU	No	FHFL	Yes	2	4,7*
4X67A89324	C2DP	ThinkSystem NVIDIA RTX 6000 Ada 48GB PCIe Active GPU	Controlled	FHFL	Yes	2	4,7*

\* When a double-wide GPU is installed in slot 4, slot 3 is unavailable; similarly when a double-wide GPU is installed in slot 7, slot 6 is unavailable

For information about these GPUs, see the ThinkSystem GPU Summary, available at: <https://lenovopress.com/lp0768-thinksystem-thinkagile-gpu-summary>

## GPU configuration rules

The following configuration requirements must be met when installing GPUs:

- The table includes a Controlled GPU column. If a GPU is listed as Controlled, that means the GPU is not offered in certain markets, as determined by the US Government. If a GPU is listed as No, that means the GPU is not controlled and is available in all markets.
- All GPUs installed must be identical
- When a double-wide GPU is installed in slot 4 or 7, the adjacent slot 3 and 6 respectively is not available
- Middle drive bays and Rear drive bays are not supported
- 12x 3.5-inch backplanes are not supported
- GPUs are not supported with the ThinkSystem V4 1U/2U Compute Complex Neptune Core Module (machine type 7DK2)

For additional GPU requirements, see the Thermal rules page in the User Guide: [https://pubs.lenovo.com/sr650-v4/thermal\\_rules](https://pubs.lenovo.com/sr650-v4/thermal_rules)

## GPU Full Length Thermal Option Kit

When installing any full-length GPU as a field upgrade, you will also need to order the GPU Enablement Kit as listed in the following table. This kit is only required for full-length GPUs and is not required for low profile GPUs such as the NVIDIA L4. See the GPU part number table above for GPU form factors.

Table 75. ThinkSystem SR650 V4 Full Length GPU Thermal Option Kit

Part number	Description	Maximum supported
4X67B04303	ThinkSystem SR650 V4 Full Length GPU Thermal Option Kit <ul style="list-style-type: none"> <li>● 2x performance heatsinks - replace existing 2U heatsinks (SBB7A85750, C3QR)</li> <li>● 1x ThinkSystem 2U GPU air duct - replaces main air baffle (SBB7A86004, C3RP)</li> <li>● 2x Air duct fillers - needed in each riser zone if no GPU is installed in that zone (SBB7A17338, B8MB)</li> <li>● 2x Air duct lower filler (SBB7A92685, C4S3)</li> <li>● 2x Air duct upper filler (SBB7A86338, C3SK)</li> <li>● 4x 16-pin GPU power cables for double-wide GPUs (SBB7A87740, C3QU)</li> </ul>	1

## GPU cable kits

The following cable kits are offered to provide auxiliary power cables for GPUs that require one. See the [GPU part numbers](#) section to see which GPUs require an auxiliary power cable.

Configuration notes:

- This cable kit is only required for field upgrades; factory (CTO) orders will automatically include any required cables.
- This cable kit is only required for GPUs that require an auxiliary power cable. See the GPU part number table.
- The cable kit is only required if you are adding *additional* GPUs to a server that already has at least one GPU installed from a CTO order. If you are doing a field upgrade to install the *first* DW GPU to a server, order the ThinkSystem SR650 V4 Full Length GPU Thermal Option Kit, 4X67B04303 instead, since 4X67B04303 includes the necessary power cables.

Table 76. GPU cable kits

Part number	Description
4X97B04860	ThinkSystem SR650/a V4 GPU Power Cable Kit <ul style="list-style-type: none"> <li>● 1x 16-pin GPU power cable (SBB7A87740, C3QU)</li> </ul>

## Fibre Channel host bus adapters

The following table lists the Fibre Channel HBAs supported by the SR650 V4.

Table 77. Fibre Channel HBAs

Part number	Feature code	Description	Maximum supported	Slots supported
<b>32Gb Fibre Channel</b>				
4XC7A96457	C5FC	ThinkSystem Emulex LPe37102 32Gb 2-port SecureHBA PCIe Fibre Channel Adapter(Generic FW)	10	1-10
4XC7A08279	BA1G	ThinkSystem QLogic QLE2770 32Gb 1-Port PCIe Fibre Channel Adapter	10	1-10
4XC7A08276	BA1F	ThinkSystem QLogic QLE2772 32Gb 2-Port PCIe Fibre Channel Adapter	10	1-10
<b>64Gb Fibre Channel</b>				
4XC7A96458	C5FD	ThinkSystem Emulex LPe38102 64Gb 2-port SecureHBA PCIe Fibre Channel Adapter(Generic FW)	10	1-10
4XC7A96744	C4L3	ThinkSystem QLogic QLE2872 64Gb 2-Port PCIe Fibre Channel Adapter(Generic FW)	10	1-10

For more information, see the list of Lenovo Press Product Guides in the Host bus adapters category:

<https://lenovopress.com/servers/options/hba>

## SAS adapters for external storage

The following table lists SAS HBAs and RAID adapters supported by SR650 V4 server for use with external storage.

Table 78. Adapters for external storage

Part number	Feature code	Description	Maximum supported	Slots supported
<b>SAS HBA - PCIe 4.0</b>				
4Y37A09724	B8P7	ThinkSystem 440-16e SAS/SATA PCIe Gen4 12Gb HBA	10	1-10
<b>RAID Adapter - PCIe 4.0</b>				
4Y37A78836	BNWJ	ThinkSystem RAID 940-8e 4GB Flash PCIe Gen4 12Gb Adapter	4	1-10

\* The RAID adapter use a flash power module (supercap), which needs to be installed in one of the available locations in the server. For field upgrades, ensure the server configuration supports the required number of supercaps. See the [RAID flash power module \(supercap\) support](#) section for details.

For a comparison of the functions of the supported storage adapters, see the ThinkSystem RAID Adapter and HBA Reference:

<https://lenovopress.lenovo.com/lp1288#sr650-v4-support=SR650%2520V4&internal-or-external-ports=External>

For more information, see the list of Lenovo Press Product Guides in the Host bus adapters and RAID adapters categories:

<https://lenovopress.com/servers/options/hba>

<https://lenovopress.com/servers/options/raid>

## Cooling

The SR650 V4 optionally supports open-loop water cooling to remove heat from the processors and memory. For details of available cooling methods, see the [Processor cooling](#) section.

The SR650 V4 server has up to six 60 mm hot-swap variable-speed fans. Five fans are needed when one processor is installed and six fans are required when two processors are installed. The server offers N+1 rotor redundancy. The server also has one or two additional fans integrated in each of the two power supplies.

System fan choices are as follows:

- Standard fans, single-rotor 24K RPM
- High performance fans, dual-rotor, 20K RPM
- Ultra performance fans, dual-rotor, 21K RPM

Fan selection is based on the configuration of the server, as follows:

**Standard fans:** Under the following conditions, Standard fans can be used:

- Processor with any TDP with Lenovo Neptune Core liquid cooling (Processor or Compute Complex cooling)
  - 2.5-inch drives: 16xSAS/SATA+8xAnyBay, 8xSAS/SATA+16xAnyBay, 24xSAS/SATA, 24xAnyBay
  - 3.5-inch drives: 12xSAS/SATA, 12xAnyBay
- Processor TDP ≤ 205W with air-cooled heatsink with any of these front drive bays
  - 2.5-inch drives: 16xSAS/SATA+8xAnyBay, 8xSAS/SATA+16xAnyBay, 24xSAS/SATA, 24xAnyBay
- Processor TDP ≤ 185W with air-cooled heatsink with any of these front drive bays
  - 3.5-inch drives: 12xSAS/SATA, 12xAnyBay
- Memory ≤ 32GB RDIMMs (any quantity)
- No mid-chassis or rear drive backplanes
- No GPUs
- Ambient temperature 35°C or lower

**Performance fans:** If any of the above conditions are not met, Performance fans are required.

**Ultra fans:** Under the following conditions, Ultra fans are required:

- E3.S front drives
- 36x 2.5-inch NVMe drive bays (24 front, 8 mid, 4 rear)

Ordering information for the fans is listed in the following table.

Table 79. Fan ordering information

Part number	Feature code	Description	Qty 1 CPU	Qty 2 CPUs
4H47B03708	C3RQ	ThinkSystem SR650/a V4 Standard Fan Module Option Kit	5	6
4H47B03709	C3RD	ThinkSystem SR650/a V4 Performance Fan Module Option Kit	5	6
4H47B03710	C3RF	ThinkSystem SR650/a V4 Ultra Fan Module Option Kit	5	6

## Power supplies

The SR650 V4 supports up to two redundant hot-swap power supplies.

The power supply choices are listed in the following table. If two power supplies are installed, both power supplies used in server must be identical.

Topics in this section:

- [Power supply LEDs](#)
- [Power cords](#)
- [Power cords \(C19 connectors\)](#)
- [-48V DC power cord](#)
- [HVAC/HVDC power cord](#)

**Tip:** When configuring a server in the DCSC configurator, power consumption is calculated precisely by interfacing with Lenovo Capacity Planner. You can therefore select the appropriate power supply for your configuration. However, do consider future upgrades that may require additional power needs.

Table 80. Power supply options

Part number	Feature code	Description	Max Qty	Capacity (230V)	Capacity (115V)	Voltage	Connector
Titanium AC power supplies - CRPS Premium							
4P57A88687	C0U7	ThinkSystem 800W 230V/115V Titanium CRPS Premium Hot-Swap Power Supply	2	800W	800W	230V/115V	C14
4P57A88621	C0U4	ThinkSystem 1300W 230V/115V Titanium CRPS Premium Hot-Swap Power Supply	2	1300W	1000W	230V/115V	C14
4P57A88689	C0U3	ThinkSystem 2000W 230V/115V Titanium CRPS Premium Hot-Swap Power Supply	2	2000W	No support*	230V	C14
4P57A88622	C0UC	ThinkSystem 2700W 230V Titanium CRPS Premium Hot-Swap Power Supply	2	2700W	-	230V	C20
4P57A88623	C0UD	ThinkSystem 3200W 230V Titanium CRPS Premium Hot-Swap Power Supply	2	3200W	-	230V	C20
Titanium AC power supplies - CRPS							
4P57A87056	BWM3	ThinkSystem 800W 230V/115V Titanium CRPS Hot-Swap Power Supply v1.4	2	800W	800W	230V/115V	C14
4P57A87628	C2Y9	ThinkSystem 1300W 230V/115V Titanium CRPS Hot-Swap Power Supply v2.4	2	1300W	1000W	230V/115V	C14
Platinum AC power supplies - CRPS							
4P57A89306	C0U8	ThinkSystem 800W 230V/115V Platinum CRPS Hot-Swap Power Supply v1.5	2	800W	800W	230V/115V	C14
4P57A89307	C0U6	ThinkSystem 1300W 230V/115V Platinum CRPS Hot-Swap Power Supply v1.5	2	1300W	1000W	230V/115V	C14
4P57A88636	C0U5	ThinkSystem 1300W 230V/115V Platinum CRPS Hot-Swap Power Supply v2.4	2	1300W	1000W	230V/115V	C14
4P57A89308	C0UA	ThinkSystem 2700W 230V Platinum CRPS Hot-Swap Power Supply v2.3	2	2700W	-	230V	C20
4P57A88628	C0UB	ThinkSystem 2700W 230V Platinum CRPS Hot-Swap Power Supply v2.4	2	2700W	-	230V	C20
HVAC/HVDC power supplies - CRPS Premium							
4P57A88627	C0TR	ThinkSystem 1300W HVAC/HVDC Platinum CRPS Premium Hot-Swap Power Supply	2	1300W	-	200-277V AC 240-380V DC	Amphenol 10167814-002
-48V DC power supplies - CRPS Premium							

Part number	Feature code	Description	Max Qty	Capacity (230V)	Capacity (115V)	Voltage	Connector
4P57A88625	C0TS	ThinkSystem 1300W -48V DC CRPS Premium Hot-Swap Power Supply	2	1300W	-	-48V	BizLink 115H0-025987-R1

\* In the SR650 V4, ThinkSystem 2000W 230V/115V Titanium CRPS Premium Hot-Swap Power Supply (4P57A88689) is only supported with high-range voltage (200-240V) even though the power supply includes 115V in the description

Supported voltage ranges are as follows:

- The 230V/115V AC power supplies support both low-range (100-127V 50/60 Hz) and high-range (200-240V 50/60 Hz) power, except where noted. For China customers, all power supplies support 240V DC.
- The -48V DC power supply supports voltage range -44V to -54V DC.
- The HVAC/HVDC power supply supports voltage ranges 200-277V AC single phase, and 240-380V DC

For inlet current requirements, see the [Physical and electrical specifications](#) section.

Power supply options do not include a line cord. See the tables below for details about supported line cords, including the power cords for the DC power supplies. For server configurations, the inclusion of a power cord is model dependent. Configure-to-order models can be configured without power cords if desired.

The SR650 V4 supports both CRPS and CRPS Premium power supplies. CRPS Premium power supplies offer the following additional features:

- Over-subscription
- More accurate power metering
- Virtual reset
- Enhanced fault detection
- System cooling assist (fan override)
- Fault LEDs
- VPD support
- Zero-output mode support (cold redundancy mode)

## Power supply LEDs

CRPS Premium power supplies have two LEDs:

- Power output/fault LED:
  - Green: The server is on and the power supply is working normally
  - Green, slow blinking (1 flash/sec): The power supply is in Zero-output/Standby mode (see below)
  - Green, fast blinking (5 flashes/sec): The power supply unit is in firmware update mode
  - Yellow: The power supply unit may have failed.
  - Off: The server is powered off, or the power supply is not working properly
- Power input LED:
  - Green: The power supply is connected to the input power source
  - Off: The power supply is disconnected from the AC power source or a power problem has occurred

CRPS power supplies have one LED:

- Green: The server is on and the power supply is working normally
- Green, blinking: The power supply unit is in firmware update mode
- Yellow: Either the power supply has failed, or two power supplies are installed but one is not connected to the input power source
- Yellow, blinking: The power supply is indicating a warning such as over-temperature warning, over-current warning, or a slow fan speed
- Off: The server is powered off, or the power supply is not working properly

**Zero-output mode:** When Zero-output mode (also known as Standby mode or Cold Redundancy mode) is configured in XCC and the server power load is sufficiently low, one of the installed power supplies enters into the Standby state while the other one delivers entire load. When the power load increases, the standby power supply will switch to Active state to provide sufficient power to the server. Zero-output mode can be enabled or disabled in the XClarity Controller web interface, Server Configuration > Power Policy. If you select Disable, then both power supplies will be in the Active state.

**Supported with CRPS Premium only :** Zero-output mode is supported with CRPS Premium power supplies, but not with CRPS non-Premium power supplies

## Power cords

Line cords and rack power cables with C13 connectors can be ordered as listed in the following table.

**115V customers:** If you plan to use the 1300W power supply with a low-range (100-127V) power source, select a power cable that is rated above 10A. Power cables that are rated at 10A or below are not supported with low-range power.

Table 81. Power cords

Part number	Feature code	Description
Rack cables - C13 to C14		
SL67B08593	BPHZ	0.5m, 10A/100-250V, C13 to C14 Jumper Cord
00Y3043	A4VP	1.0m, 10A/100-250V, C13 to C14 Jumper Cord
4L67A08367	B0N5	1.0m, 13A/100-250V, C13 to C14 Jumper Cord
39Y7937	6201	1.5m, 10A/100-250V, C13 to C14 Jumper Cord
4L67A08368	B0N6	1.5m, 13A/100-250V, C13 to C14 Jumper Cord
4L67A08365	B0N4	2.0m, 10A/100-250V, C13 to C14 Jumper Cord
4L67A08369	6570	2.0m, 13A/100-250V, C13 to C14 Jumper Cord
4L67A08366	6311	2.8m, 10A/100-250V, C13 to C14 Jumper Cord
4L67A08370	6400	2.8m, 13A/100-250V, C13 to C14 Jumper Cord
39Y7932	6263	4.3m, 10A/100-250V, C13 to C14 Jumper Cord
4L67A08371	6583	4.3m, 13A/100-250V, C13 to C14 Rack Power Cable
Rack cables - C13 to C14 (Y-cable)		
00Y3046	A4VQ	1.345m, 2X C13 to C14 Jumper Cord, Rack Power Cable
00Y3047	A4VR	2.054m, 2X C13 to C14 Jumper Cord, Rack Power Cable
Rack cables - C13 to C20		
39Y7938	6204	2.8m, 10A/100-250V, C13 to IEC 320-C20 Rack Power Cable
Rack cables - C13 to C20 (Y-cable)		
47C2491	A3SW	1.2m, 16A/100-250V, 2 Short C13s to Short C20 Rack Power Cable
47C2492	A3SX	2.5m, 16A/100-250V, 2 Long C13s to Short C20 Rack Power Cable
47C2493	A3SY	2.8m, 16A/100-250V, 2 Short C13s to Long C20 Rack Power Cable
47C2494	A3SZ	4.1m, 16A/100-250V, 2 Long C13s to Long C20 Rack Power Cable
Line cords		
39Y7930	6222	2.8m, 10A/250V, C13 to IRAM 2073 (Argentina) Line Cord
81Y2384	6492	4.3m 10A/220V, C13 to IRAM 2073 (Argentina) Line Cord
39Y7924	6211	2.8m, 10A/250V, C13 to AS/NZ 3112 (Australia/NZ) Line Cord
81Y2383	6574	4.3m, 10A/230V, C13 to AS/NZS 3112 (Aus/NZ) Line Cord

Part number	Feature code	Description
69Y1988	6532	2.8m, 10A/250V, C13 to NBR 14136 (Brazil) Line Cord
81Y2387	6404	4.3m, 10A/250V, C13 - 2P+Gnd (Brazil) Line Cord
39Y7928	6210	2.8m, 10A/220V, C13 to GB 2099.1 (China) Line Cord
81Y2378	6580	4.3m, 10A/220V, C13 to GB 2099.1 (China) Line Cord
39Y7918	6213	2.8m, 10A/250V, C13 to DK2-5a (Denmark) Line Cord
81Y2382	6575	4.3m, 10A/230V, C13 to DK2-5a (Denmark) Line Cord
39Y7917	6212	2.8m, 10A/230V, C13 to CEE7-VII (Europe) Line Cord
81Y2376	6572	4.3m, 10A/230V, C13 to CEE7-VII (Europe) Line Cord
39Y7927	6269	2.8m, 10A/250V, C13(2P+Gnd) (India) Line Cord
81Y2386	6567	4.3m, 10A/240V, C13 to IS 6538 (India) Line Cord
39Y7920	6218	2.8m, 10A/250V, C13 to SI 32 (Israel) Line Cord
81Y2381	6579	4.3m, 10A/230V, C13 to SI 32 (Israel) Line Cord
39Y7921	6217	2.8m, 220-240V, C13 to CEI 23-16 (Italy/Chile) Line Cord
81Y2380	6493	4.3m, 10A/230V, C13 to CEI 23-16 (Italy/Chile) Line Cord
46M2593	A1RE	2.8m, 12A/125V, C13 to JIS C-8303 (Japan) Line Cord
4L67A08362	6495	4.3m, 12A/200V, C13 to JIS C-8303 (Japan) Line Cord
39Y7926	6335	4.3m, 12A/100V, C13 to JIS C-8303 (Japan) Line Cord
39Y7922	6214	2.8m, 10A/250V, C13 to SABS 164 (S Africa) Line Cord
81Y2379	6576	4.3m, 10A/230V, C13 to SABS 164 (South Africa) Line Cord
39Y7925	6219	2.8m, 220-240V, C13 to KETI (S Korea) Line Cord
81Y2385	6494	4.3m, 12A/220V, C13 to KSC 8305 (S. Korea) Line Cord
39Y7919	6216	2.8m, 10A/250V, C13 to SEV 1011-S24507 (Swiss) Line Cord
81Y2390	6578	4.3m, 10A/230V, C13 to SEV 1011-S24507 (Sws) Line Cord
23R7158	6386	2.8m, 10A/125V, C13 to CNS 10917-3 (Taiwan) Line Cord
81Y2375	6317	2.8m, 10A/240V, C13 to CNS 10917-3 (Taiwan) Line Cord
81Y2374	6402	2.8m, 13A/125V, C13 to CNS 60799 (Taiwan) Line Cord
4L67A08363	AX8B	4.3m, 10A 125V, C13 to CNS 10917 (Taiwan) Line Cord
81Y2389	6531	4.3m, 10A/250V, C13 to 76 CNS 10917-3 (Taiwan) Line Cord
81Y2388	6530	4.3m, 13A/125V, C13 to CNS 10917 (Taiwan) Line Cord
39Y7923	6215	2.8m, 10A/250V, C13 to BS 1363/A (UK) Line Cord
81Y2377	6577	4.3m, 10A/230V, C13 to BS 1363/A (UK) Line Cord
90Y3016	6313	2.8m, 10A/120V, C13 to NEMA 5-15P (US) Line Cord
46M2592	A1RF	2.8m, 10A/250V, C13 to NEMA 6-15P Line Cord
00WH545	6401	2.8m, 13A/120V, C13 to NEMA 5-15P (US) Line Cord
4L67A08359	6370	4.3m, 10A/125V, C13 to NEMA 5-15P (US) Line Cord
4L67A08361	6373	4.3m, 10A/250V, C13 to NEMA 6-15P (US) Line Cord
4L67A08360	AX8A	4.3m, 13A/120V, C13 to NEMA 5-15P (US) Line Cord

### Power cords (C19 connectors)

Line cords and rack power cables with C19 connectors can be ordered as listed in the following table.

Table 82. Power cords (C19 connectors)

Part number	Feature code	Description
<b>Rack cables</b>		
4L67A86677	BPJ0	0.5m, 16A/100-250V, C19 to IEC 320-C20 Rack Power Cable
4L67A86678	B4L0	1.0m, 16A/100-250V, C19 to IEC 320-C20 Rack Power Cable
4L67A86679	B4L1	1.5m, 16A/100-250V, C19 to IEC 320-C20 Rack Power Cable
4L67A86680	B4L2	2.0m, 16A/100-250V, C19 to IEC 320-C20 Rack Power Cable
39Y7916	6252	2.5m, 16A/100-240V, C19 to IEC 320-C20 Rack Power Cable
4L67A86681	B4L3	4.3m, 16A/100-250V, C19 to IEC 320-C20 Rack Power Cable
<b>Line cords</b>		
40K9777	6276	4.3m, 220-240V, C19 to IRAM 2073 (Argentina) Line cord
40K9773	6284	4.3m, 220-240V, C19 to AS/NZS 3112 (Aus/NZ) Line cord
40K9775	6277	4.3m, 250V, C19 to NBR 14136 (Brazil) Line Cord
40K9774	6288	4.3m, 220-240V, C19 to GB2099.1 (China) Line cord
40K9769	6283	4.3m, 16A/230V, C19 to IEC 309-P+N+G (Den/Sws) Line Cord
40K9766	6279	4.3m, 220-240V, C19 to CEE7-VII (European) Line cord
40K9776	6285	4.3m, 220-240V, C19 to IS6538 (India) Line cord
40K9771	6282	4.3m, 220-240V, C19 to SI 32 (Israel) Line cord
40K9768	6281	4.3m, 220-240V, C19 to CEI 23-16 (Italy) Line cord
40K9770	6280	4.3m, 220-240V, C19 to SABS 164 (South Africa) Line cord
41Y9231	6289	4.3m, 15A/250V, C19 to KSC 8305 (S. Korea) Line Cord
81Y2391	6549	4.3m, 16A/230V, C19 to SEV 1011 (Sws) Line Cord
41Y9230	6287	4.3m, 16A/250V, C19 to CNS 10917-3 (Taiwan) Line Cord
40K9767	6278	4.3m, 220-240V, C19 to BS 1363/A w/13A fuse (UK) Line Cord
40K9772	6275	4.3m, 16A/208V, C19 to NEMA L6-20P (US) Line Cord
00D7197	A1NV	4.3m, 15A/250V, C19 to NEMA 6-15P (US) Line Cord

**-48V DC power cord**

For the -48V DC Power Supply, the following power cable is supported.

Table 83. -48V DC power cable

Part number	Feature code	Description
4L67A97438	C682	2.8m, 38A /-48V, -48V (3V3) Line Cord

The following figure shows the power cable.

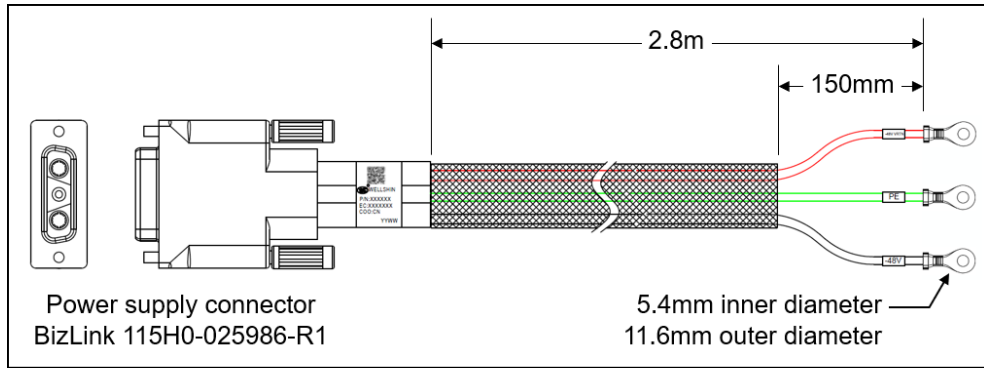

Figure 30. -48V DC power cord

### HVAC/HVDC power cord

For the HVDC Power Supply, the following power cable is supported.

Table 84. -48V DC power cable

Part number	Feature code	Description
4L67A97238	C683	2.8M,10A/400V,HVDC Line Cord

The following figure shows the power cable.

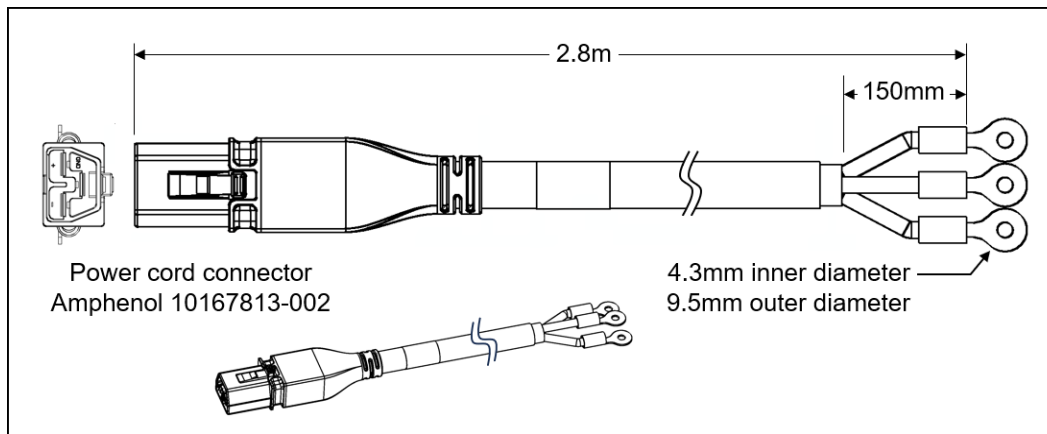

Figure 31. HVDC power cord

### Systems management

The SR650 V4 contains an integrated service processor, XClarity Controller 3 (XCC3), which provides advanced control, monitoring, and alerting functions. The XCC3 is based on an OpenBMC design, using the AST2600 baseboard management controller (BMC) with a dual-core ARM Cortex A7 32-bit RISC service processor running at 1.2 GHz.

Topics in this section:

- [System I/O Board \(DC-SCM\)](#)
- [Local management](#)
- [System status with XClarity Mobile](#)
- [Remote management](#)
- [Shared connectivity for remote management](#)
- [MicroSD for XCC local storage](#)

- [XCC3 Premier](#)
- [Lenovo XClarity Provisioning Manager](#)
- [Lenovo XClarity One](#)
- [Lenovo XClarity Administrator](#)
- [Lenovo XClarity Integrators](#)
- [Lenovo XClarity Essentials](#)
- [Lenovo XClarity Energy Manager](#)
- [Lenovo Capacity Planner](#)

## System I/O Board (DC-SCM)

The SR650 V4 implements a separate System I/O Board, also known as the DC-SCM (Data Center Secure Control Module, DCSCM), that connects to the system board as shown in the Internal view in the [Components and connectors](#) section. The System I/O Board contains connectors that are accessible from the exterior of the server as shown in the following figure.

**Note:** The NMI (non-maskable interrupt) button is not accessible from the rear of the server. Lenovo recommends using the NMI function that is part of the XCC user interfaces instead.

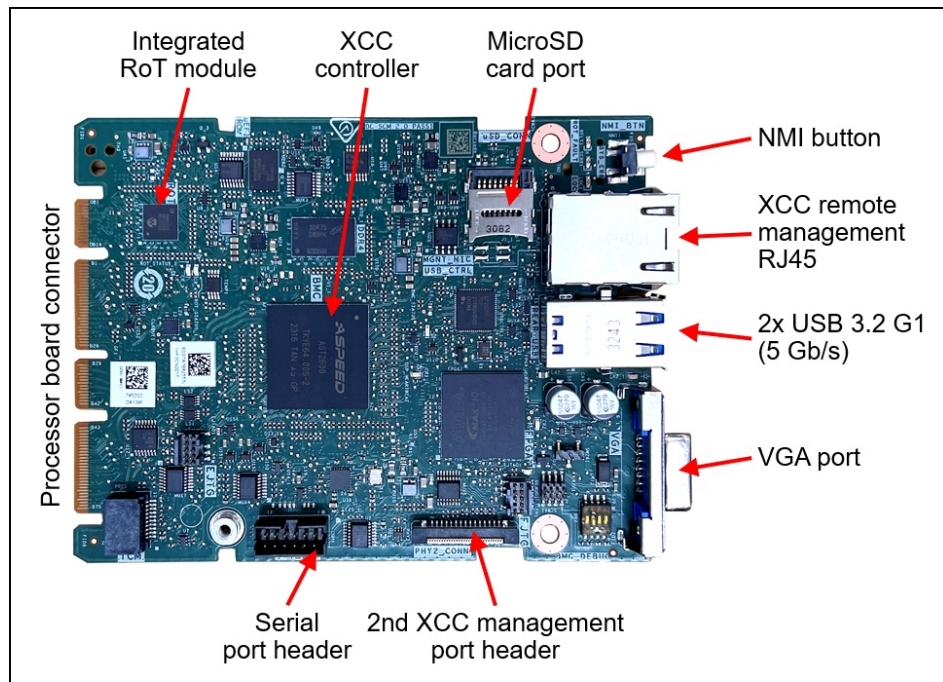

Figure 32. System I/O Board

The board also has the following components:

- XClarity Controller 3, implemented using the ASPEED AST2600 baseboard management controller (BMC).
- Root of Trust (RoT) module - implements Platform Firmware Resiliency (PFR) hardware Root of Trust (RoT) which enables the server to be NIST SP800-193 compliant. For more details about PFR, see the [Security](#) section.
- MicroSD card port to enable the use of a MicroSD card for additional storage for use with the XCC3 controller. XCC3 can use the storage as a Remote Disc on Card (RDOC) device (up to 4GB of storage). It can also be used to store firmware updates (including N-1 firmware history) for ease of deployment.

**Tip:** Without a MicroSD card installed, the XCC controller will have 100MB of available RDOC storage.

Ordering information for the supported Micro SD cards are listed in the [MicroSD for XCC local storage](#) section.

## Local management

The SR650 V4 offers a front operator panel with key LED status indicators, as shown in the following figure.

**Tip:** The Network LED only shows network activity of an installed OCP network adapter. The LED shows activity from both OCP adapters if two are installed.

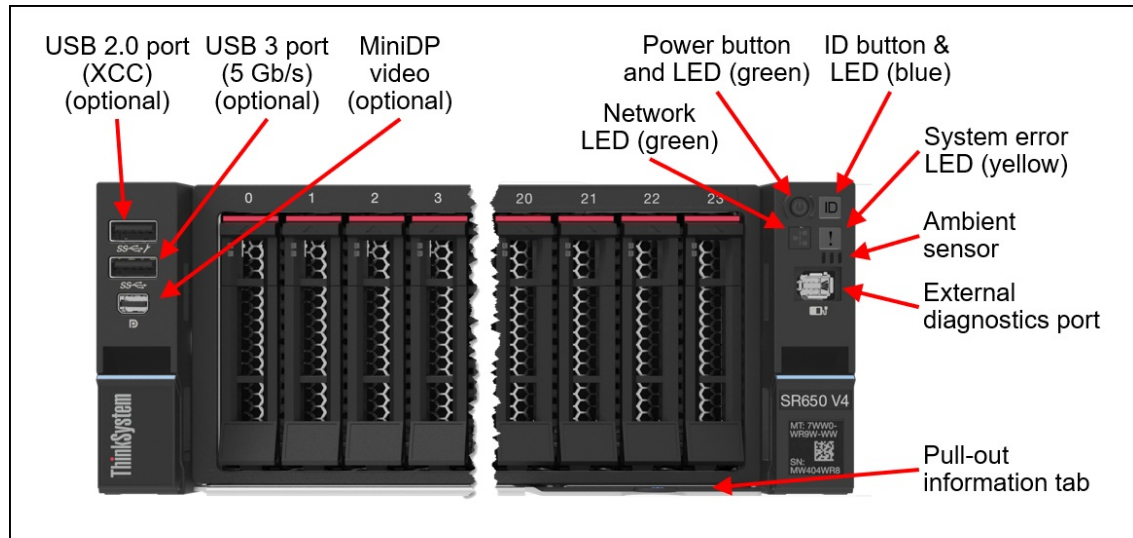

Figure 33. Front operator controls are on the left and right side of the server

### Front DisplayPort video port and Front/Internal USB ports

The rear USB ports and VGA video port are standard on all models of the SR650 V4, however the front and internal USB ports, and front MiniDP video port are optional, and can be configured in the factory in CTO orders, or as field upgrades using option part numbers.

**Internal USB port:** The internal USB port supports USB drives that have an overall length of less than 30mm. See the [USB flash drive](#) section for the supported drive.

For CTO orders, the feature codes are listed in the following table.

Table 85. CTO orders - Front & internal ports

Feature code	Description	Purpose
BQQ2	ThinkSystem 2U V3 EIA Latch Standard	No front USB ports, no MiniDP video port
C1YR	ThinkSystem 1U/2U V4 USB Ports Extension Board	Provides the Internal USB 3 port (5 Gb/s)
C3RG*	ThinkSystem SR650 V4 Left Rack Latch with USB/MiniDP	Provides the 2x Front USB 3 ports (5 Gb/s) and MiniDP 1.1a port (requires Internal USB port, C1YR)

\* Feature C1YR must also be selected

Configuration rules:

- The Internal USB port (C1YR) can be selected without also selecting the front USB/MiniDP ports
- The Front USB ports and MiniDP requires that the Internal USB port (C1YR) also be selected
- The front USB ports are required to use XClarity Mobile, as described in the [System status with XClarity Mobile](#) section.

For field upgrades, the part numbers listed in the following table are available.

Table 86. Local management

Part number	Description	Purpose
4XF7B03892	ThinkSystem SR650/a V4 Left Rack Latch with USB/MiniDP Option kit <ul style="list-style-type: none"> <li>• USB I/O board with Internal USB port</li> <li>• Front media bezel with USB ports and MiniDP port for SR650 V4</li> <li>• Front media bezel with USB ports and MiniDP port for SR650a V4</li> </ul>	Adds Internal USB 3 port (5 Gb/s), 2x Front USB 3 ports (5 Gb/s), MiniDP 1.1a video port  See the <a href="#">USB flash drive</a> section for supported USB drives for internal USB port.
4XF7A99087	ThinkSystem V4 Internal USB I/O Board Option kit <ul style="list-style-type: none"> <li>• USB I/O board with Internal USB port</li> </ul>	Adds Internal USB 3 port (5 Gb/s) only.

Configuration notes for field upgrades:

- If you order ThinkSystem 1U/2U V4 Front Media Bay Option kit (4X97A96850) for use in a server that already has the internal USB port installed (feature C1YR), the USB I/O board from the kit will not be needed as it is a duplicate of what is already installed.
- ThinkSystem 1U/2U V4 Front Media Bay Option kit (4X97A96850) is required to use XClarity Mobile, as described in the [System status with XClarity Mobile](#) section.

### External Diagnostics Handset

The SR650 V4 optionally has a port to connect an External Diagnostics Handset as described in the preceding section. The External Diagnostics Handset has the same functions as the Integrated Diagnostics Panel but has the advantages of not consuming space on the front of the server plus it can be shared among many servers in your data center. The handset has a magnet on the back of it to allow you to easily mount it on a convenient place on any rack cabinet.

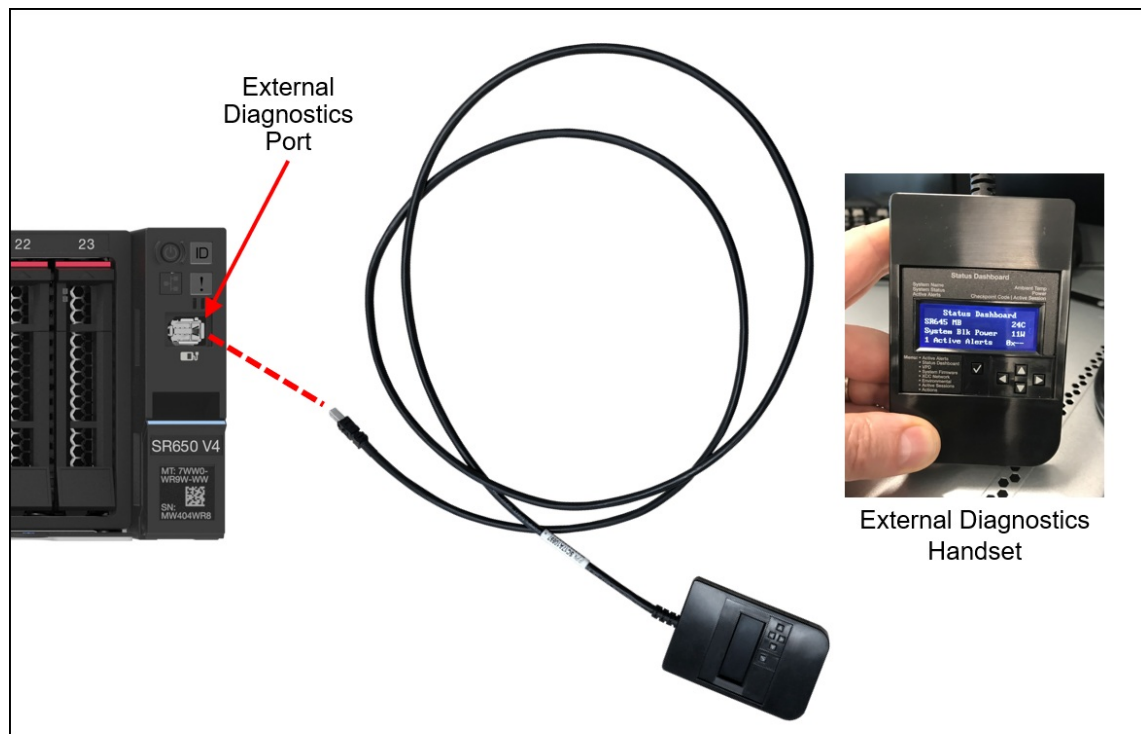

Figure 34. External Diagnostics Handset

The External Diagnostics Handset allows quick access to system status, firmware, network, and health information. The LCD display and the function buttons give you access to the following information:

- Active alerts (support planned for 4Q/2025)
- Status Dashboard (support planned for 4Q/2025)
- System VPD: machine type & mode, serial number, UUID string
- System firmware levels: UEFI and XCC firmware
- XCC network information: hostname, MAC address, IP address, DNS addresses (support planned for 4Q/2025)
- Environmental data: Ambient temperature, CPU temperature, AC input voltage, estimated power consumption (support planned for 4Q/2025)
- Active XCC sessions (support planned for 4Q/2025)
- System reset action (support planned for 4Q/2025)

Ordering information for the External Diagnostics Handset with is listed in the following table.

Table 87. External Diagnostics Handset ordering information

Part number	Feature code	Description
4TA7A64874	BEUX	ThinkSystem External Diagnostics Handset

### Information pull-out tab

The front of the server also houses an information pull-out tab (also known as the network access tag). See [Figure 2](#) for the location. A label on the tab shows the network information (MAC address and other data) to remotely access the service processor.

### Light path diagnostics

The server offers light path diagnostics. If an environmental condition exceeds a threshold or if a system component fails, XCC lights LEDs inside the server to help you diagnose the problem and find the failing part.

The server has fault LEDs next to the following components:

- Each memory DIMM
- Each drive bay
- Each power supply

### System status with XClarity Mobile

**Support is planned:** Support for XClarity Mobile on the SR650 V4 is planned for 4Q/2025.

The XClarity Mobile app includes a tethering function where you can connect your Android or iOS device to the server via USB to see the status of the server.

The steps to connect the mobile device are as follows:

1. Enable USB Management on the server, by holding down the ID button for 3 seconds (or pressing the dedicated USB management button if one is present)
2. Connect the mobile device via a USB cable to the server's USB port with the management symbol 
3. In iOS or Android settings, enable Personal Hotspot or USB Tethering
4. Launch the Lenovo XClarity Mobile app

Once connected you can see the following information:

- Server status including error logs (read only, no login required)
- Server management functions (XClarity login credentials required)

Configuration notes:

- The use of XClarity Mobile requires front USB ports. If your server doesn't already include front USB ports, order the field upgrade ThinkSystem SR650/a V4 Left Rack Latch with USB/MiniDP Option kit (4XF7B03892) as described in the [Local management](#) section

## Remote management

The server offers a dedicated RJ45 Ethernet port at the rear of the server for remote management via the XClarity Controller management processor. The port supports 10/100/1000 Mbps speeds.

Remote server management is provided through industry-standard interfaces:

- Intelligent Platform Management Interface (IPMI) Version 2.0
- Simple Network Management Protocol (SNMP) Version 3 (no SET commands; no SNMP v1)
- Common Information Model (CIM-XML)
- Representational State Transfer (REST) support
- Redfish support (DMTF compliant)
- Web browser - HTML 5-based browser interface (Java and ActiveX not required) using a responsive design (content optimized for device being used - laptop, tablet, phone) with NLS support

IPMI via the Ethernet port (IPMI over LAN) is supported, however it is disabled by default. For CTO orders you can specify whether you want the feature enabled or disabled in the factory, using the feature codes listed in the following table.

Table 88. IPMI-over-LAN settings

Feature code	Description
B7XZ	Disable IPMI-over-LAN (default)
B7Y0	Enable IPMI-over-LAN

The SR650 V4 also supports the use of an OCP adapter that provides an additional redundant Ethernet connection to the XCC3 controller. Ordering information is listed in the following table.

Table 89. Redundant System Management Port Adapter

Part number	Feature code	Description	Maximum quantity
4XC7A99825	C1XD	ThinkSystem V4 Management NIC Adapter Kit	1

The use of this adapter allows concurrent remote access using both the connection on the adapter and the onboard RJ45 remote management port provided by the server. The adapter and onboard port have separate IP addresses.

Configuration rules:

- The adapter is only supported in OCP slot 1

## Shared connectivity for remote management

To reduce the number of Ethernet connections needed for remote management, the SR650 V4 supports an adapter that installs in the OCP slot that allows four servers to share the one Ethernet connection. The adapter implements a 5-port Gigabit switch based on the Microchip KSZ9896 switch chip. Ordering information is listed in the following table.

Table 90. 4-to-1 Management Port Consolidation Adapter

Part number	Feature code	Description
4XC7A90299	BZGE	ThinkSystem OCP 4 to 1 Management Port Consolidation Adapter  Contains: <ul style="list-style-type: none"> <li>• 1x OCP adapter</li> <li>• 2x 0.45m blue Cat5e cable</li> <li>• 1x 0.25m blue Cat5e cable</li> </ul>

The adapter has four RJ45 ports. One port of the adapter connects to the local remote management port and the other three adapter ports connect to the remote management ports of three nearby servers. Either the included short Cat5e cables can be used or customer-supplied Cat5e Ethernet cables can be used.

Configuration notes:

- The adapter is only supported in OCP slot 1
- When the adapter is installed in slot 1, OCP slot 2 is disabled and cannot be used
- The OCP slot in the other three servers can be used for network connectivity, if desired.

### MicroSD for XCC local storage

The server includes a MicroSD card port to enable the use of a MicroSD card for additional storage for use with the XCC controller. XCC can use the storage as a Remote Disc on Card (RDOC) device (up to 4GB of storage). It can also be used to store firmware updates (including N-1 firmware history) for ease of deployment.

**Tip:** Without a MicroSD card installed, the XCC controller will have 100MB of available RDOC storage.

Ordering information for the supported Micro SD cards is listed in the following table.

Table 91. Media for use with the MicroSD card port

Part number	Feature code	Description
4X77A92672	C0BC	ThinkSystem MicroSD 64GB Class 10 Flash Memory Card

### XCC3 Premier

The XCC3 service processor in the SR650 V4 supports an upgrade to the Premier level of features. XCC3 Premier in ThinkSystem V4 servers is equivalent to the XCC2 Premium offering in ThinkSystem V3 servers.

XCC3 Premier adds the following functions:

- Enterprise Strict Security mode - Enforces CNSA 1.0 level security
- Remotely viewing video with graphics resolutions up to 1600x1200 at 75 Hz with up to 23 bits per pixel, regardless of the system state
- Remotely accessing the server using the keyboard and mouse from a remote client
- International keyboard mapping support
- Redirecting serial console via SSH
- Component replacement log (Maintenance History log)
- Access restriction (IP address blocking)
- Displaying graphics for real-time and historical power usage data and temperature
- Mapping the ISO and image files located on the local client as virtual drives for use by the server
- Mounting the remote ISO and image files via HTTPS, SFTP, CIFS, and NFS
- Power capping
- License for XClarity Energy Manager

The following additional XCC3 Premier features are planned for 2Q/2025

- System Guard - Monitor hardware inventory for unexpected component changes, and simply log the event

- or prevent booting
- Neighbor Group - Enables administrators to manage and synchronize configurations and firmware level across multiple servers
- Syslog alerting
- Lenovo SED security key management
- Boot video capture and crash video capture
- Virtual console collaboration - Ability for up to 6 remote users to be log into the remote session simultaneously
- Remote console Java client
- System utilization data and graphic view
- Single sign on with Lenovo XClarity Administrator
- Update firmware from a repository

Ordering information is listed in the following table. XCC3 Premier is a software license upgrade - no additional hardware is required.

Table 92. XCC3 Premier license upgrade

Part number	Feature code	Description
7S0X000XWW	SCY0	Lenovo XClarity Controller 3 (XCC3) Premier

With XCC3 Premier, for CTO orders, you can request that System Guard be enabled in the factory and the first configuration snapshot be recorded. To add this to an order, select feature code listed in the following table. The selection is made in the Security tab of the configurator.

Table 93. Enable System Guard in the factory (CTO orders)

Feature code	Description
BUT2	Install System Guard

For more information about System Guard, see [https://pubs.lenovo.com/xcc2/NN1ia\\_c\\_systemguard](https://pubs.lenovo.com/xcc2/NN1ia_c_systemguard)

### Lenovo XClarity Provisioning Manager

Lenovo XClarity Provisioning Manager (LXPM) is a UEFI-based application embedded in ThinkSystem servers and accessible via the F1 key during system boot.

LXPM provides the following functions:

- Graphical UEFI Setup
- System inventory information and VPD update
- System firmware updates (UEFI and XCC)
- RAID setup wizard
- OS installation wizard (including unattended OS installation)
- Diagnostics functions

### Lenovo XClarity One

Lenovo XClarity One is a hybrid cloud-based unified Management-as-a-Service (MaaS) platform, built for growing enterprises. XClarity One is powered by Lenovo Smarter Support, a powerful AI-driven platform that leverages predictive analytics to enhance the performance, reliability, and overall efficiency of Lenovo servers.

XClarity One is the next milestone in Lenovo's portfolio of systems management products. Now you can leverage the benefits of a true next-generation, hybrid cloud-based solution for the deployment, management, and maintenance of your infrastructure through a single, centralized platform that delivers a consistent user experience across all Lenovo products.

Key features include:

- **AI-powered Automation**

Harnesses the power of AI and predictive analytics to enhance the performance and reliability of your infrastructure with proactive protection.

- **AI-Powered Predictive Failure Analytics** - predict maintenance needs before the failure occurs, with the ability to visualize aggregated actions in customer dashboard.
- **AI-Powered Call-Home** - A Call-Home serviceable event opens a support ticket automatically, leveraging AI technology for problem determination and fast resolution.
- **AI-Powered Premier Support with Auto CRU** - uses AI to automatically dispatch parts and services, reducing service costs and minimizing downtime.

- **Secure Management Hub**

Lenovo's proprietary Management Hub is an on-premises virtual appliance that acts as the bridge between your infrastructure and the cloud.

- **On-Premises Security with Cloud Flexibility** - your infrastructure has no direct connection to the cloud, greatly reducing your attack surface from external threats while still having the deployment benefits, flexibility, and scalability of a cloud solution.
- **Authentication and Authorization** - built on a Zero Trust Architecture and requiring OTP Application authentication for all users to handle the support of all customers' servers and client devices. Role-based access controls help define and restrict permissions based on user roles.

- **AI-Powered Management**

Go beyond standard system management leveraging AI algorithms to continuously learn from data patterns to optimize performance and predict potential issues before they impact operations.

- **AI Customizable Insights and Reporting** - Customize AI-generated insights and reports to align with specific business objectives, enabling data-driven decision-making and strategic planning.
- **AI-driven scalability and flexibility** - Guided with AI-driven predictions, the platform supports dynamic scaling of resources based on workload demands.
- **Monitor and Change** - AI Advanced analytics capabilities providing deep insights into server performance, resource utilization, and security threats, to detect anomalies and suggest optimizations in real-time. NLP capabilities enabling administrators to interact with the platform using voice commands or text queries.
- **Upward Integration** - Integrated with Lenovo Open Cloud Automation (LOC-A), Lenovo Intelligent Computer Orchestration (LiCO) and AIOps engines providing an end-to-end management architecture across Lenovo infrastructure and devices solutions.
- **Cross-Platform Compatibility** - Compatibility across different server types and cloud environments

Lenovo XClarity One is an optional management component. License information for XClarity One is listed in the following table.

Table 94. XClarity One license information

Part number	Description
7S0X000LWW	XClarity One - Managed Device, Per Endpoint w/1 Yr SW S&S
7S0X000MWW	XClarity One - Managed Device, Per Endpoint w/3 Yr SW S&S
7S0X000NWW	XClarity One - Managed Device, Per Endpoint w/5 Yr SW S&S

For more information, see these resources:

- Lenovo XClarity One datasheet:  
<https://lenovopress.lenovo.com/ds0188-lenovo-xclarity-one>
- Lenovo XClarity One product guide:  
<https://lenovopress.lenovo.com/lp1992-lenovo-xclarity-one>

## Lenovo XClarity Administrator

Lenovo XClarity Administrator is a centralized resource management solution designed to reduce complexity, speed response, and enhance the availability of Lenovo systems and solutions. It provides agent-free hardware management for ThinkSystem servers. The administration dashboard is based on HTML 5 and allows fast location of resources so tasks can be run quickly.

Because Lenovo XClarity Administrator does not require any agent software to be installed on the managed endpoints, there are no CPU cycles spent on agent execution, and no memory is used, which means that up to 1GB of RAM and 1 - 2% CPU usage is saved, compared to a typical managed system where an agent is required.

Lenovo XClarity Administrator is an optional software component for the SR650 V4. The software can be downloaded and used at no charge to discover and monitor the SR650 V4 and to manage firmware upgrades.

If software support is required for Lenovo XClarity Administrator, or premium features such as configuration management and operating system deployment are required, Lenovo XClarity Pro software subscription should be ordered. Lenovo XClarity Pro is licensed on a per managed system basis, that is, each managed Lenovo system requires a license.

The following table lists the Lenovo XClarity software license options.

Table 95. Lenovo XClarity Pro ordering information

Part number	Feature code	Description
00MT201	1339	Lenovo XClarity Pro, per Managed Endpoint w/1 Yr SW S&S
00MT202	1340	Lenovo XClarity Pro, per Managed Endpoint w/3 Yr SW S&S
00MT203	1341	Lenovo XClarity Pro, per Managed Endpoint w/5 Yr SW S&S
7S0X000HWW	SAYV	Lenovo XClarity Pro, per Managed Endpoint w/6 Yr SW S&S
7S0X000JWW	SAYW	Lenovo XClarity Pro, per Managed Endpoint w/7 Yr SW S&S

Lenovo XClarity Administrator offers the following standard features that are available at no charge:

- Auto-discovery and monitoring of Lenovo systems
- Firmware updates and compliance enforcement
- External alerts and notifications via SNMP traps, syslog remote logging, and e-mail
- Secure connections to managed endpoints
- NIST 800-131A or FIPS 140-3 compliant cryptographic standards between the management solution and managed endpoints
- Integration into existing higher-level management systems such as cloud automation and orchestration tools through REST APIs, providing extensive external visibility and control over hardware resources
- An intuitive, easy-to-use GUI
- Scripting with Windows PowerShell, providing command-line visibility and control over hardware resources

Lenovo XClarity Administrator offers the following premium features that require an optional Pro license:

- Pattern-based configuration management that allows to define configurations once and apply repeatedly without errors when deploying new servers or redeploying existing servers without disrupting the fabric
- Bare-metal deployment of operating systems and hypervisors to streamline infrastructure provisioning

For more information, refer to the Lenovo XClarity Administrator Product Guide:

<http://lenovopress.com/tips1200>

## Lenovo XClarity Integrators

Lenovo also offers software plug-in modules, Lenovo XClarity Integrators, to manage physical infrastructure from leading external virtualization management software tools including those from Microsoft and VMware.

These integrators are offered at no charge, however if software support is required, a Lenovo XClarity Pro software subscription license should be ordered.

Lenovo XClarity Integrators offer the following additional features:

- Ability to discover, manage, and monitor Lenovo server hardware from VMware vCenter or Microsoft System Center
- Deployment of firmware updates and configuration patterns to Lenovo x86 [rack servers](#) and Flex System from the virtualization management tool
- Non-disruptive server maintenance in clustered environments that reduces workload downtime by dynamically migrating workloads from affected hosts during rolling server updates or reboots
- Greater service level uptime and assurance in clustered environments during unplanned hardware events by dynamically triggering workload migration from impacted hosts when impending hardware failures are predicted

For more information about all the available Lenovo XClarity Integrators, see the Lenovo XClarity Administrator Product Guide: <https://lenovopress.com/tips1200-lenovo-xclarity-administrator>

## Lenovo XClarity Essentials

Lenovo offers the following XClarity Essentials software tools that can help you set up, use, and maintain the server at no additional cost:

- **Lenovo Essentials OneCLI**  
OneCLI is a collection of server management tools that uses a command line interface program to manage firmware, hardware, and operating systems. It provides functions to collect full system health information (including health status), configure system settings, and update system firmware and drivers.
- **Lenovo Essentials UpdateXpress**  
The UpdateXpress tool is a standalone GUI application for firmware and device driver updates that enables you to maintain your server firmware and device drivers up-to-date and help you avoid unnecessary server outages. The tool acquires and deploys individual updates and UpdateXpress System Packs (UXSPs) which are integration-tested bundles.
- **Lenovo Essentials Bootable Media Creator**  
The Bootable Media Creator (BOMC) tool is used to create bootable media for offline firmware update.

**ThinkSystem V4 servers:** The format of UEFI and BMC settings has changed for ThinkSystem V4 servers, to align with OpenBMC and Redfish requirements. See the documentation of these tools for details. As a result, the following versions are required for these servers:

- OneCLI 5.x or later
- UpdateXpress 5.x or later
- BOMC 14.x or later

For more information and downloads, visit the Lenovo XClarity Essentials web page: <http://support.lenovo.com/us/en/documents/LNVO-center>

## Lenovo XClarity Energy Manager

Lenovo XClarity Energy Manager (LXEM) is a power and temperature management solution for data centers. It is an agent-free, web-based console that enables you to monitor and manage power consumption and temperature in your data center through the management console. It enables server density and data center capacity to be increased through the use of power capping.

LXEM is a licensed product. A single-node LXEM license is included with the XClarity Controller Premier upgrade as described in the [XCC3 Premier](#) section. If your server does not have the XCC Premier upgrade, Energy Manager licenses can be ordered as shown in the following table.

Table 96. Lenovo XClarity Energy Manager

Part number	Description
4L40E51621	Lenovo XClarity Energy Manager Node License (1 license needed per server)

For more information about XClarity Energy Manager, see the following resources:

- Lenovo Support page:  
<https://datacentersupport.lenovo.com/us/en/solutions/Invo-lxem>
- User Guide for XClarity Energy Manager:  
<https://pubs.lenovo.com/lxem/>

## Lenovo Capacity Planner

Lenovo Capacity Planner is a power consumption evaluation tool that enhances data center planning by enabling IT administrators and pre-sales professionals to understand various power characteristics of racks, servers, and other devices. Capacity Planner can dynamically calculate the power consumption, current, British Thermal Unit (BTU), and volt-ampere (VA) rating at the rack level, improving the planning efficiency for large scale deployments.

For more information, refer to the Capacity Planner web page:  
<http://datacentersupport.lenovo.com/us/en/solutions/Invo-lcp>

## Security

Topics in this section:

- [Security features](#)
- [Platform Firmware Resiliency - Lenovo ThinkShield](#)
- [Security standards](#)

### Security features

The SR650 V4 server offers the following electronic security features:

- Secure Boot function of the Intel Xeon processor
- Support for Platform Firmware Resiliency (PFR) hardware Root of Trust (RoT) - see the [Platform Firmware Resiliency](#) section
- Firmware signature processes compliant with FIPS and NIST requirements
- System Guard (part of [XCC3 Premier](#)) - Proactive monitoring of hardware inventory for unexpected component changes
- Administrator and power-on password
- Integrated Trusted Platform Module (TPM) supporting TPM 2.0
- For China users, optional Nationz TPM 2.0 module
- Self-encrypting drives (SEDs) with support for enterprise key managers - see the [SED encryption key management](#) section

The server is NIST SP 800-147B compliant.

The SR650 V4 server also offers the following optional physical security features:

- Optional chassis intrusion switch
- Optional lockable front security bezel

The optional lockable front security bezel is shown in the following figure and includes a key that enables you to secure the bezel over the drives and system controls thereby reducing the chance of unauthorized or accidental access to the server.



Figure 35. Lockable front security bezel

The dimensions of the security bezel are:

- Width: 435 mm (17.1 in.)
- Height: 87 mm (3.4 in.)
- Width: 30 mm (1.2 in.)

The following table lists the security options for the SR650 V4.

Table 97. Security features

Part number	Feature code	Description
4X97B03890	C3QT	ThinkSystem SR650/a V4 Intrusion Cable kit
4XF7B03891	C1S5	ThinkSystem V4 2U Bezel Option Kit
CTO only	C8UF	ThinkSystem V4 PRC NationZ TPM 2.0 Module

### Platform Firmware Resiliency - Lenovo ThinkShield

Lenovo's ThinkShield Security is a transparent and comprehensive approach to security that extends to all dimensions of our data center products: from development, to supply chain, and through the entire product lifecycle.

The ThinkSystem SR650 V4 includes Platform Firmware Resiliency (PFR) hardware Root of Trust (RoT) which enables the system to be NIST SP800-193 compliant. This offering further enhances key platform subsystem protections against unauthorized firmware updates and corruption, to restore firmware to an integral state, and to closely monitor firmware for possible compromise from cyber-attacks.

PFR operates upon the following server components:

- UEFI image – the low-level server firmware that connects the operating system to the server hardware
- XCC image – the management “engine” software that controls and reports on the server status separate from the server operating system
- FPGA image – the code that runs the server's lowest level hardware controller on the motherboard

The Lenovo Platform Root of Trust Hardware performs the following three main functions:

- Detection – Measures the firmware and updates for authenticity
- Recovery – Recovers a corrupted image to a known-safe image
- Protection – Monitors the system to ensure the known-good firmware is not maliciously written

These enhanced protection capabilities are implemented using a dedicated, discrete security processor whose implementation has been rigorously validated by leading third-party security firms. Security evaluation results and design details are available for customer review – providing unprecedented transparency and assurance.

The SR650 V4 includes support for Secure Boot, a UEFI firmware security feature developed by the UEFI Consortium that ensures only immutable and signed software are loaded during the boot time. The use of Secure Boot helps prevent malicious code from being loaded and helps prevent attacks, such as the installation of rootkits. Lenovo offers the capability to enable secure boot in the factory, to ensure end-to-end protection. Alternatively, Secure Boot can be left disabled in the factory, allowing the customer to enable it themselves at a later point, if desired.

The following table lists the relevant feature code(s).

Table 98. Secure Boot options

Part number	Feature code	Description	Purpose
CTO only	BPKQ	TPM 2.0 with Secure Boot	Configure the system in the factory with Secure Boot enabled.
CTO only	BPKR	TPM 2.0	Configure the system without Secure Boot enabled. Customers can enable Secure Boot later if desired.

**Tip:** If Secure Boot is not enabled in the factory, it can be enabled later by the customer. However once Secure Boot is enabled, it cannot be disabled.

## Security standards

The SR650 V4 supports the following security standards and capabilities:

- **Industry Standard Security Capabilities**

- Intel CPU Enablement
  - Intel Trust Domain Extensions (Intel TDX)
  - Intel Crypto Acceleration
  - Intel QuickAssist Software Acceleration
  - Intel Platform Firmware Resilience Support
  - Intel Control-Flow Enforcement Technology
  - Intel Total Memory Encryption - Multi Key
  - Intel Total Memory Encryption
  - Intel AES New Instructions (AES-NI)
  - Intel OS Guard
  - Execute Disable Bit (XD)
  - Intel Boot Guard
  - Mode-based Execute Control (MBEC)
  - Intel Virtualization Technology (VT-x)
  - Intel Virtualization Technology for Directed I/O (VT-d)
- Microsoft Windows Security Enablement
  - Credential Guard
  - Device Guard
  - Host Guardian Service
- TCG (Trusted Computing Group) TPM (Trusted Platform Module) 2.0
- UEFI (Unified Extensible Firmware Interface) Forum Secure Boot

- **Hardware Root of Trust and Security**

- Independent security subsystem providing platform-wide NIST SP800-193 compliant Platform Firmware Resilience (PFR)
- Management domain RoT supplemented by the Secure Boot features of XCC

- **Platform Security**

- Boot and run-time firmware integrity monitoring with rollback to known-good firmware (e.g., “self-healing”)
- Non-volatile storage bus security monitoring and filtering
- Resilient firmware implementation, such as to detect and defeat unauthorized flash writes or SMM (System Management Mode) memory incursions
- Patented IPMI KCS channel privileged access authorization (USPTO Patent# 11,256,810)
- Host and management domain authorization, including integration with CyberArk for enterprise password management

- KMIP (Key Management Interoperability Protocol) compliant, including support for IBM SKLM and Thales KeySecure
- Reduced “out of box” attack surface
- Configurable network services

For more information on platform security, see the paper “How to Harden the Security of your ThinkSystem Server and Management Applications” available from <https://lenovopress.com/lp1260-how-to-harden-the-security-of-your-thinksystem-server>.

- **Standards Compliance and/or Support**

- NIST SP800-131A rev 2 “Transitioning the Use of Cryptographic Algorithms and Key Lengths”
- NIST SP800-147B “BIOS Protection Guidelines for Servers”
- NIST SP800-193 “Platform Firmware Resiliency Guidelines”
- ISO/IEC 11889 “Trusted Platform Module Library”
- Common Criteria TCG Protection Profile for “PC Client Specific TPM 2.0”
- European Union Commission Regulation 2019/424 (“ErP Lot 9”) “Ecodesign Requirements for Servers and Data Storage Products” Secure Data Deletion
- Optional FIPS 140-2 validated Self-Encrypting Disks (SEDs) with external KMIP-based key management

- **Product and Supply Chain Security**

- Suppliers validated through Lenovo’s Trusted Supplier Program
- Developed in accordance with Lenovo’s Secure Development Lifecycle (LSDL)
- Continuous firmware security validation through automated testing, including static code analysis, dynamic network and web vulnerability testing, software composition analysis, and subsystem-specific testing, such as UEFI security configuration validation
- Ongoing security reviews by US-based security experts, with attestation letters available from our third-party security partners
- Digitally signed firmware, stored and built on US-based infrastructure and signed on US-based Hardware Security Modules (HSMs)
- TAA (Trade Agreements Act) compliant manufacturing, by default in Mexico for North American markets with additional US and EU manufacturing options
- US 2019 NDAA (National Defense Authorization Act) Section 889 compliant

## Rack installation

The following table lists the rack installation options that are available for the SR650 V4.

For supported racks, see the [Rack cabinets](#) section.

Table 99. Rack installation options

Part number	Feature Code	Description	CMA support
Rail kits			
4XF7A97379	C2DG	ThinkSystem Toolless Friction Rail V4	No support
4XF7A97370	C2DH	ThinkSystem Toolless Slide Rail Kit V4	Optional
4XF7A97374	C3QS	ThinkSystem Toolless Slide Rail Kit V4 with 2U CMA	Included
4XF7A97371	C2DJ	ThinkSystem Advanced Toolless Slide Rail Kit V4	Optional
4XF7A97376	C3UF	ThinkSystem Advanced Toolless Slide Rail Kit V4 with 2U CMA	Included
Cable management arm for field upgrades (for CTO orders, use one of the above kits with CMA included)			
7M27A05698	-	ThinkSystem 2U CMA Upgrade Kit for Toolless Slide Rail	Yes

See the Rail Kit comparison for the specifications of each rail kit:

<https://lenovopress.lenovo.com/lp1838-thinksystem-and-thinkedge-rail-kit-reference#availability=Available&sr650-v4-support=SR650%2520V4>

**Tip:** The Advanced rail kits add support for threaded mounting holes.

## Operating system support

The SR650 V4 supports the following operating systems:

- Microsoft Windows Server 2022
- Microsoft Windows Server 2025
- Red Hat Enterprise Linux 9.4
- Red Hat Enterprise Linux 9.5
- SUSE Linux Enterprise Server 15 SP6
- Ubuntu 22.04 LTS 64-bit
- Ubuntu 24.04 LTS 64-bit
- VMware ESXi 8.0 U3

For a complete list of supported, certified and tested operating systems, plus additional details and links to relevant web sites, see the Operating System Interoperability Guide: <https://lenovopress.lenovo.com/osig>

For configure-to-order configurations, the SR650 V4 can be preloaded with VMware ESXi. Ordering information is listed in the following table.

Table 100. VMware ESXi preload

Part number	Feature code	Description
-------------	--------------	-------------

Configuration rule:

- An ESXi preload cannot be selected if the configuration includes an NVIDIA GPU (ESXi preload cannot include the NVIDIA driver)

You can download supported VMware vSphere hypervisor images from the following web page and install it using the instructions provided:

[https://vmware.lenovo.com/content/custom\\_iso/](https://vmware.lenovo.com/content/custom_iso/)

## Physical and electrical specifications

The SR650 V4 has the following overall physical dimensions, excluding components that extend outside the standard chassis, such as EIA flanges, front security bezel (if any), and power supply handles:

- Width: 445 mm (17.5 inches)
- Height: 87 mm (3.4 inches)
- Depth: 796 mm (31.3 inches)

The following table lists the detailed dimensions. See the figure below for the definition of each dimension.

Table 101. Detailed dimensions

Dimension	Description
482 mm	$X_a$ = Width, to the outsides of the front EIA flanges
435 mm	$X_b$ = Width, to the rack rail mating surfaces
445 mm	$X_c$ = Width, to the outer most chassis body feature
87 mm	$Y_a$ = Height, from the bottom of chassis to the top of the chassis
723 mm	$Z_a$ = Depth, from the rack flange mating surface to the rearmost I/O port surface
761 mm	$Z_b$ = Depth, from the rack flange mating surface to the rearmost feature of the chassis body
752 mm	$Z_c$ = Depth, from the rack flange mating surface to the rearmost feature such as power supply handle
35 mm	$Z_d$ = Depth, from the forwardmost feature on front of EIA flange to the rack flange mating surface
51 mm	$Z_e$ = Depth, from the front of security bezel (if applicable) or forwardmost feature to the rack flange mating surface

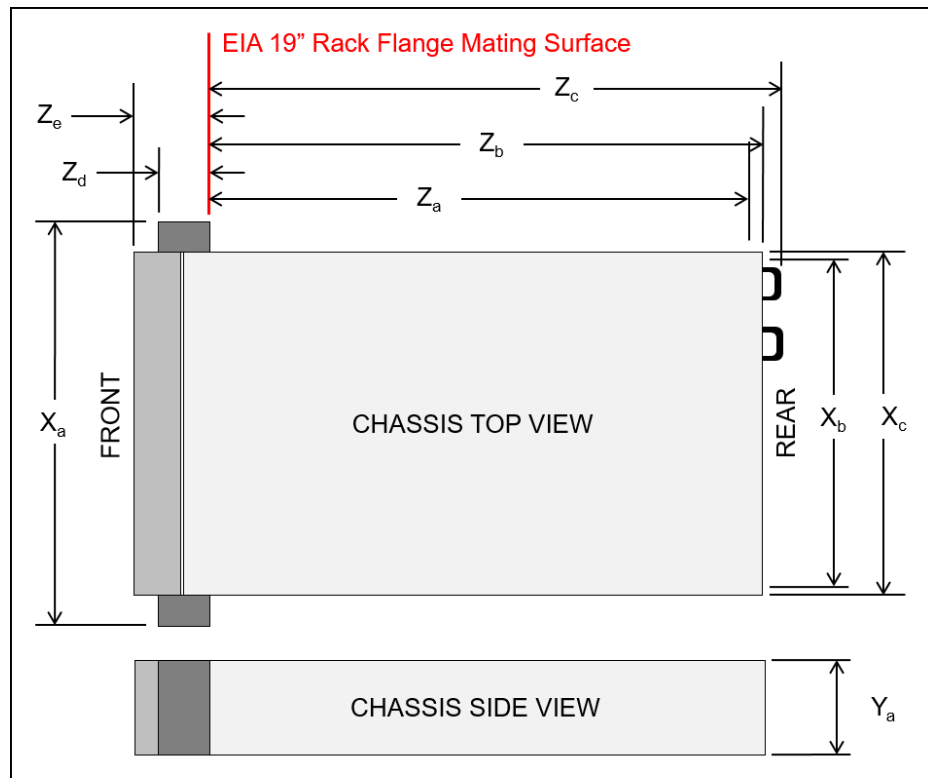

Figure 36. Server dimensions

The shipping (cardboard packaging) dimensions of the SR650 V4 are as follows:

- Width: 592 mm (23.3 inches)
- Height: 282 mm (11.1 inches)
- Depth: 992 mm (39.1 inches)

The server has the following weight:

- Maximum weight: 38.8 kg (85.5 lb)

The server has the following electrical specifications for AC input power supplies:

- Input voltage:
  - 100 to 127 (nominal) Vac, 50 Hz or 60 Hz
  - 200 to 240 (nominal) Vac, 50 Hz or 60 Hz
  - 180 to 300 Vdc (China only)
- Inlet current: see the following table.

Table 102. Maximum inlet current

Part number	Description	100V AC	200V AC	240V DC
<b>Titanium AC power supplies</b>				
4P57A88687	ThinkSystem 800W 230V/115V Titanium CRPS Premium Hot-Swap Power Supply	9.3A	4.5A	4A
4P57A87056	ThinkSystem 800W 230V/115V Titanium CRPS Hot-Swap Power Supply v1.4	10A	5A	5A
4P57A88621	ThinkSystem 1300W 230V/115V Titanium CRPS Premium Hot-Swap Power Supply	11.4A	7.2A	6.2A
4P57A87628	ThinkSystem 1300W 230V/115V Titanium CRPS Hot-Swap Power Supply v2.4	12A	8A	8A
4P57A88689	ThinkSystem 2000W 230V/115V Titanium CRPS Premium Hot-Swap Power Supply	No support	11A	9.1A
<b>Platinum AC power supplies</b>				
4P57A89306	ThinkSystem 800W 230V/115V Platinum CRPS Hot-Swap Power Supply v1.5	10A	5A	4.5A
4P57A89307	ThinkSystem 1300W 230V/115V Platinum CRPS Hot-Swap Power Supply v1.5	12A	8A	6.5A
4P57A88636	ThinkSystem 1300W 230V/115V Platinum CRPS Hot-Swap Power Supply v2.4	12A	8A	8A
<b>HVAC/HVDC power supplies</b>				
4P57A88627	ThinkSystem 1300W HVAC/HVDC Platinum CRPS Premium Hot-Swap Power Supply	No support	7.2A	6.2A

Electrical specifications for -48V DC input power supply, 4P57A88625:

- Input voltage: -48 to -60 Vdc
- Inlet current: 29.8 A

Electrical specifications for HVAC/HVDC power supply, 4P57A88627:

- Input voltage ranges:
  - 200-277V AC single phase
  - 240-380V DC
- Inlet current:
  - AC: 7.2 A

- DC: 6.2 A

## Operating environment

The SR650 V4 server complies with ASHRAE Class A2 specifications with most configurations, and depending on the hardware configuration, also complies with ASHRAE Class A3 and Class A4 specifications. System performance may be impacted when operating temperature is outside ASHRAE A2 specification.

Depending on the hardware configuration, the SR650 V4 server also complies with ASHRAE Class H1 specification. System performance may be impacted when operating temperature is outside ASHRAE H1 specification.

Topics in this section:

- [Ambient temperature requirements](#)
- [Temperature and humidity](#)
- [Acoustical noise emissions](#)
- [Shock and vibration](#)
- [Particulate contamination](#)

### Ambient temperature requirements

The restrictions to ASHRAE support are as follows.

#### Air-cooled configurations - ambient requirements

The restrictions to ASHRAE support are as follows (cooling by air):

- The ambient temperature must be no more than 35°C in any of the following configurations:
  - standard configurations with  $\geq 64$  GB DIMMs or  $> 205$  W processors
  - storage configurations without middle or rear drive bays
  - GPU configurations
  - configurations with special parts listed in [Thermal rules](#)
- The ambient temperature must be no more than 30°C in any of the following configurations:
  - storage configurations with middle or rear drive bays
  - storage or GPU configurations with MRDIMMs or 256 GB 3DS RDIMMs
  - configurations with special parts listed in [Thermal rules](#)
- The ambient temperature must be no more than 25°C in any of the following configurations:
  - configurations with processor 6732P
  - storage configurations with ThinkSystem NVIDIA BlueField-3 VPI QSFP112 2P 200G PCIe Gen5 x16 B3220
  - storage configurations with a ConnectX-8 adapter used with ThinkSystem NDR/NDR200 QSFP112 IB Multi Mode Solo-Transceiver
  - GPU configurations with 16 x 2.5" AnyBay front drive bays and ThinkSystem NVIDIA BlueField-3 VPI QSFP112 2P 200G PCIe Gen5 x16 B3220
  - GPU configurations with 24 x 2.5" AnyBay front drive bays and a ConnectX-8 adapter used with ThinkSystem NDR/NDR200 QSFP112 IB Multi Mode Solo-Transceiver
  - configurations with special parts listed in [Thermal rules](#)

#### Processor Neptune Core open-loop water configurations - ambient requirements

The restrictions to ASHRAE support are as follows (cooling by ThinkSystem V4 1U/2U Processor Neptune Core Module, feature C1XH):

- The ambient temperature must be no more than 30°C in any of the following configurations:
  - 36 NVMe configurations with standard fans
  - standard configurations with standard fans and MRDIMMs or 256 GB 3DS RDIMMs
  - GPU configurations with MRDIMMs or 256 GB 3DS RDIMMs
  - standard configurations with ThinkSystem NVIDIA BlueField-3 VPI QSFP112 2P 200G PCIe Gen5 x16 B3220
  - storage configurations with ConnectX-8 adapter

- The ambient temperature must be no more than 25°C in any of the following configurations:
  - storage configurations with 12 x 3.5" front drive bays, standard fans, and MRDIMMs or 256 GB 3DS RDIMMs
  - storage configurations with ThinkSystem NVIDIA BlueField-3 VPI QSFP112 2P 200G PCIe Gen5 x16 B3220

### Compute Complex Neptune Core Module open-loop water configurations - ambient requirements

The restrictions to ASHRAE support are as follows (cooling by Compute Complex Neptune Core Module):

- The ambient temperature must be no more than 35°C in the following configurations:
  - configurations with special parts listed in [Thermal rules](#)
- The ambient temperature must be no more than 30°C in the following configurations:
  - configurations with ThinkSystem NVIDIA BlueField-3 VPI QSFP112 2P 200G PCIe Gen5 x16 B3220

For additional information, see the Environmental specifications and Thermal rules sections in the product documentation:

[https://pubs.lenovo.com/sr650-v4/server\\_specifications\\_environmental](https://pubs.lenovo.com/sr650-v4/server_specifications_environmental)

[https://pubs.lenovo.com/sr650-v4/thermal\\_rules](https://pubs.lenovo.com/sr650-v4/thermal_rules)

### Water requirements

The SR650 V4 has the following requirements for open-loop liquid cooling:

- Maximum pressure: 3 bars
- Water inlet temperature and flow rates for Compute Complex Neptune Core Module:
  - 45°C (113°F) inlet temperature: 1 liter per minute (lpm) per server
- Water inlet temperature and flow rates for Processor Neptune Core Module:
  - 50°C (122°F) inlet temperature: 1.5 liters per minute (lpm) per server
  - 45°C (113°F) inlet temperature: 1 liter per minute (lpm) per server
  - 40°C (104°F) or lower inlet temperature: 0.5 liters per minute (lpm) per server

The water required to initially fill the system side cooling loop must be reasonably clean, bacteria-free water (<100 CFU/ml) such as de-mineralized water, reverse osmosis water, de-ionized water, or distilled water. The water must be filtered with an in-line 50 micron filter (approximately 288 mesh). The water must be treated with anti-biological and anti-corrosion measures. Environment quality must be maintain over the lifetime of the system to receive warranty and support on affecting components. For more information, see [Lenovo Neptune Direct Water-Cooling Standards](#).

### Temperature and humidity

The server is supported in the following environment:

- Air temperature:
  - Operating:
    - ASHRAE Class A2: 10°C to 35°C (50°F to 95°F); the maximum ambient temperature decreases by 1°C for every 300 m (984 ft) increase in altitude above 900 m (2,953 ft).
    - ASHRAE Class A3: 5°C to 40°C (41°F to 104°F); the maximum ambient temperature decreases by 1°C for every 175 m (574 ft) increase in altitude above 900 m (2,953 ft).
    - ASHRAE Class A4: 5°C to 45°C (41°F to 113°F); the maximum ambient temperature decreases by 1°C for every 125 m (410 ft) increase in altitude above 900 m (2,953 ft).
    - ASHRAE Class H1: 5 °C to 25 °C (41 °F to 77 °F); Decrease the maximum ambient temperature by 1°C for every 500 m (1640 ft) increase in altitude above 900 m (2,953 ft).
  - Server off: -10°C to 60°C (14°F to 140°F)
  - Shipment/storage: -40°C to 70°C (-40°F to 158°F)
- Maximum altitude: 3,050 m (10,000 ft)
- Relative Humidity (non-condensing):
  - Operating
    - ASHRAE Class A2: 8% to 80%; maximum dew point: 21°C (70°F)
    - ASHRAE Class A3: 8% to 85%; maximum dew point: 24°C (75°F)

- ASHRAE Class A4: 8% to 90%; maximum dew point: 24°C (75°F)
- ASHRAE Class H1: 8% to 80%; Maximum dew point: 17°C (63°F)
- Shipment/storage: 8% to 90%

## Acoustical noise emissions

The server has the following acoustic noise emissions declaration.

Table 103. Acoustic noise emissions declaration

Acoustic performance @ 25°C ambient	Configuration	Min	Typical	Storage	GPU rich
Declared mean A-weighted sound power level, LWA,m (B) Statistical adder for verification, Kv (B) = 0.4	Idle mode	5.6	5.9	6.8	6.8
	Operating mode 1	5.9	6.2	6.8	7.3
	Operating mode 2	6.4	6.7	8.4	8.7
Declared mean A-weighted emission sound pressure level, LpA,m (dB) Bystander position	Idle mode	44	47	56	56
	Operating mode 1	47	50	56	62
	Operating mode 2	52	54	71	75

Modes:

- Idle mode: The steady-state condition in which the server is powered-on but not operating any intended function.
- Operating mode 1: The maximum acoustic output of 50% CPU TDP or active storage drives
- Operating mode 2: The maximum acoustical output of 100% CPU TDP or GPU TDP

The declared acoustic sound levels are based on the following configurations, which may change depending on configuration or conditions.

- **Min:** 2 x 250 W CPUs, 8 x 64 GB RDIMMs, 8 x 2.5" SAS HDDs, 1 x RAID 940-8i, 1 x ThinkSystem Broadcom 5719 1GbE RJ45 4-port OCP Ethernet Adapter, 2 x 1300 W PSUs
- **Typical:** 2 x 270 W CPUs, 16 x 64 GB RDIMMs, 16 x 2.5" SAS HDDs, 1 x RAID 940-16i, 2 x ThinkSystem Broadcom 57414 10/25GbE SFP28 2-port OCP Ethernet Adapter, 2 x 1300W PSUs
- **GPU rich:** 2 x 350 W CPUs, 2 x H100 NVL GPUs, 16 x 64 GB RDIMMs, 8 x 2.5" NVMe drives, 2 x ThinkSystem Broadcom 57508 100GbE QSFP56 2-Port OCP Ethernet Adapter, 2 x 2700W PSUs
- **Storage rich:** 2 x 270 W CPUs, 16 x 64 GB RDIMMs, 16 x 3.5" SAS HDDs, 1 x RAID 940-16i, 2 x ThinkSystem Broadcom 57414 10/25GbE SFP28 2-port OCP Ethernet Adapter, 2 x 1300 W PSUs

Notes:

- These sound levels were measured in controlled acoustical environments according to procedures specified by ISO7779 and are reported in accordance with ISO 9296.
- The declared sound levels may change depending on configuration/conditions.
- Government regulations (such as those prescribed by OSHA or European Community Directives) may govern noise level exposure in the workplace and may apply to you and your server installation. The actual sound pressure levels in your installation depend upon a variety of factors, including the number of racks in the installation; the size, materials, and configuration of the room; the noise levels from other equipment; the room ambient temperature, and employee's location in relation to the equipment. Further, compliance with such government regulations depends on a variety of additional factors, including the duration of employees' exposure and whether employees wear hearing protection. Lenovo recommends that you consult with qualified experts in this field to determine whether you are in compliance with the applicable regulations.

## Shock and vibration

The server has the following vibration and shock limits:

- Vibration:
  - Operating: 0.21 G rms at 5 Hz to 500 Hz for 15 minutes across 3 axes
  - Non-operating: 1.04 G rms at 2 Hz to 200 Hz for 15 minutes across 6 surfaces
- Shock:
  - Operating: 15 G for 3 milliseconds in each direction (positive and negative X, Y, and Z axes)
  - Non-operating:
    - 12 kg - 22 kg: 50 G for 152 in./sec velocity change across 6 surfaces
    - 23 kg - 31 kg: 35 G for 152 in./sec velocity change across 6 surfaces (3x GPU config, 2.5" config)
    - 32 kg - 68 kg: 35 G for 136 in./sec velocity change across 6 surfaces (16x 3.5" HDD config)

## Particulate contamination

Airborne particulates (including metal flakes or particles) and reactive gases acting alone or in combination with other environmental factors such as humidity or temperature might damage the system that might cause the system to malfunction or stop working altogether.

The following specifications indicate the limits of particulates that the system can tolerate:

- Reactive gases:
  - The copper reactivity level shall be less than 200 Angstroms per month (Å/month)
  - The silver reactivity level shall be less than 200 Å/month
- Airborne particulates:
  - The room air should be continuously filtered with MERV 8 filters.
  - Air entering a data center should be filtered with MERV 11 or preferably MERV 13 filters.
  - The deliquescent relative humidity of the particulate contamination should be more than 60% RH
  - Environment must be free of zinc whiskers

For additional information, see the Specifications section of the documentation for the server, available from the Lenovo Documents site, <https://pubs.lenovo.com/>

## Water infrastructure for the Lenovo Processor Neptune Core Module

The Lenovo Processor Neptune Core Module is the liquid-based processor cooling offering for the SR650 V4, as described in the [Lenovo Processor Neptune Core Module](#) section.

The open-loop cooling module requires the following water infrastructure components in the rack cabinet and data center:

- Supported 42U or 48U rack cabinet

The 42U or 48U Heavy Duty Rack Cabinet (machine types 7D6D or 7D6E) are supported. Two 0U mounting points are required for the water manifolds, at the rear of the rack cabinet, one either side.

For information about the 42U and 48U Heavy Duty Rack Cabinets, see the product guide: <https://lenovopress.lenovo.com/lp1498-lenovo-heavy-duty-rack-cabinets>
- 38-port water manifold (machine type 7DE6), installed in the rear of the rack cabinet

The manifold provides quick-disconnect couplings that each server in the rack are connected to. Ordering information is in the table below.

- Coolant distribution unit (CDU), either in-rack or in-row
  - In-rack CDUs are installed at the bottom of the rack cabinet. The supported in-rack CDU is as follows:
    - Lenovo Neptune DWC RM100 In-Rack CDU; see the [RM100 In-Rack Coolant Distribution Unit](#) section
  - In-row CDUs are separate cabinets that are typically installed at the end of a row of rack cabinets. Examples of suitable in-row CDUs include (but not limited to):
    - CoolTera FS400 310KW CDU
    - Vertiv Liebert XDU60 60KW CDU
- Hose kit to connect to the CDU to the manifold
  - Ordering information is in the table below.

The following figure shows the major components of the solution.

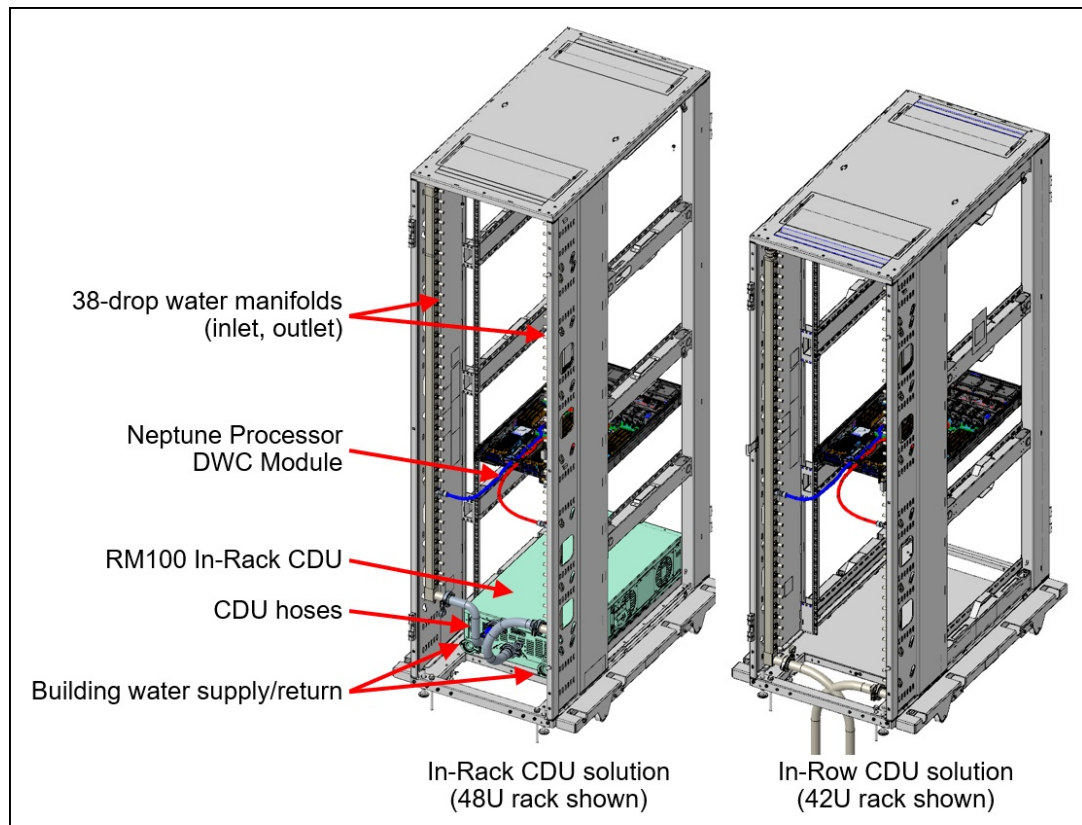

Figure 37. Water manifold connections

Configuration requirements:

- Maximum number of SR650 V4 servers supported in a rack:
  - 48U rack: 19 servers
  - 42U rack with in-rack CDU: 18 servers
  - 42U rack without in-rack CDU: 19 servers
- Inlet water flow rate:
  - 0.5 LPM: Maximum 40°C inlet water temperature
  - 1.0 LPM: Maximum 45°C inlet water temperature
  - 1.5 LPM: Maximum 50°C inlet water temperature
- Water pressure requirement:
  - Maximum operating node inlet pressure = 43.5 psi (3 bars)

**Note:** Water quality must be maintained over the lifetime of the system to receive warranty and support on affecting components. For water quality requirement, see [Lenovo Neptune Direct Water-Cooling Standards](#)

The 38-drop water manifold and hoses can be ordered as listed in the following table.

Table 104. Water infrastructure ordering information

Part number	Feature code	Description
Manifold for 42U and 48U rack cabinet		
4XF7A90061	C5YW	ThinkSystem Neptune DWC 38 Port Rack Manifold
Hoses to connect the manifold to an in-rack CDU		
4XF7A90232	C5YX	Connection Set - 38/45 Ports Manifold with in-rack CDU
4XF7A90233	C5YY	Connection Set, for 38 Ports manifold with in-Rack CDU in 48U Rack
Hoses to connect the manifold to an in-row CDU		
4XF7A90234	C5YZ	Hose Set, 1 inch EPDM, 1.3m, for 38 Ports manifold for in-row CDU
4XF7A90235	C5Z0	Hose Set, 1 inch EPDM, 2.3m, for 38 Ports manifold for in-row CDU

Configuration notes:

- This water connection solution described here cannot be used with the DW612S and N1380 enclosures as the water requirements are different.
- The hoses for in-row CDUs that are listed in the table above have Eaton FD83 quick-disconnect couplings

## RM100 In-Rack Coolant Distribution Unit

The RM100 In-Rack Coolant Distribution Unit (CDU) can provide 100kW cooling capacity within the rack cabinet. It is designed as a 4U high rack device installed at the bottom of the rack. The CDU is supported in the 42U and 48U Heavy Duty Rack Cabinets.

For information about the 42U and 48U Heavy Duty Rack Cabinets, see the product guide: <https://lenovopress.lenovo.com/lp1498-lenovo-heavy-duty-rack-cabinets>

The following figure shows the RM100 CDU.



Figure 38. RM100 In-Rack Coolant Distribution Unit

The CDU can be ordered using the CTO process in the configurators using machine type 7DBL. The following table lists the base CTO model and base feature code.

Table 105. RM100 ordering information

CTO model	Base feature	Description
7DBLCTOLWW	BRL4	Lenovo Neptune DWC RM100 In-Rack CDU

For details and exact specification of the CDU, see the In-Rack CDU Operation & Maintenance Guide:

[https://pubs.lenovo.com/hdc\\_rackcabinet/rm100\\_user\\_guide.pdf](https://pubs.lenovo.com/hdc_rackcabinet/rm100_user_guide.pdf)

**Professional Services:** The factory integration of the In-Rack CDU requires Lenovo Professional Services review and approval for warranty and associated extended services. Before ordering CDU and manifold, contact the Lenovo Professional Services team ([CDUsupport@lenovo.com](mailto:CDUsupport@lenovo.com)).

## Warranty upgrades and post-warranty support

The SR650 V4 has a 1-year or 3-year warranty based on the machine type of the system:

- 7DGC, 7DGE - 1 year warranty
- 7DGD, 7DK2, 7DLN, 7DGF - 3 year warranty

Our global network of regional support centers offers consistent, local-language support enabling you to vary response times and level of service to match the criticality of your support needs:

- **Standard Next Business Day** – Best choice for non-essential systems requiring simple maintenance.
- **Premier Next Business Day** – Best choice for essential systems requiring technical expertise from senior-level Lenovo engineers.
- **Premier 24x7 4-Hour Response** – Best choice for systems where maximum uptime is critical.
- **Premier Enhanced Storage Support 24x7 4-Hour Response** – Best choice for storage systems where maximum uptime is critical.

For more information, consult the brochure [Lenovo Operational Support Services for Data Centers Services](#).

## Services

Lenovo Data Center Services empower you at every stage of your IT lifecycle. From expert advisory and strategic planning to seamless deployment and ongoing support, we ensure your infrastructure is built for success. Our comprehensive services accelerate time to value, minimize downtime, and free your IT staff to focus on driving innovation and business growth.

**Note:** Some service options may not be available in all markets or regions. For more information, go to <https://lenovocator.com/>. For information about Lenovo service upgrade offerings that are available in your region, contact your local Lenovo sales representative or business partner.

In this section:

- [Lenovo Advisory Services](#)
- [Lenovo Plan & Design Services](#)
- [Lenovo Deployment, Migration, and Configuration Services](#)
- [Lenovo Support Services](#)
- [Lenovo Managed Services](#)
- [Lenovo Sustainability Services](#)

### Lenovo Advisory Services

Lenovo Advisory Services simplify the planning process, enabling customers to build future-proofed strategies in as little as six weeks. Consultants provide guidance on projects including VM migration, storage, backup and recovery, and cost management to accelerate time to value, improve cost efficiency, and build a flexibly scalable foundation.

- **Assessment Services**

An Assessment helps solve your IT challenges through an onsite, multi-day session with a Lenovo technology expert. We perform a tools-based assessment which provides a comprehensive and thorough review of a company's environment and technology systems. In addition to the technology based functional requirements, the consultant also discusses and records the non-functional business requirements, challenges, and constraints. Assessments help organizations like yours, no matter how large or small, get a better return on your IT investment and overcome challenges in the ever-changing technology landscape.

- **Design Services**

Professional Services consultants perform infrastructure design and implementation planning to support your strategy. The high-level architectures provided by the assessment service are turned into low level designs and wiring diagrams, which are reviewed and approved prior to implementation. The implementation plan will demonstrate an outcome-based proposal to provide business capabilities through infrastructure with a risk-mitigated project plan.

### Lenovo Plan & Design Services

Unlock faster time to market with our tailored, strategic design workshops to align solution approaches with your business goals and technical requirements. Leverage our deep solution expertise and end-to-end delivery partnership to meet your goals efficiently and effectively.

### Lenovo Deployment, Migration, and Configuration Services

Optimize your IT operations by shifting labor-intensive functions to Lenovo's skilled technicians for seamless on-site or remote deployment, configuration, and migration. Enjoy peace of mind, faster time to value, and comprehensive knowledge sharing with your IT staff, backed by our best-practice methodology.

- **Deployment Services for Storage and ThinkAgile**

A comprehensive range of remote and onsite options tailored specifically for your business needs to ensure your storage and ThinkAgile hardware are fully operational from the start.

- **Hardware Installation Services**

A full-range, comprehensive setup for your hardware, including unpacking, inspecting, and positioning components to ensure your equipment is operational and error-free for the most seamless and efficient installation experience, so you can quickly benefit from your investments.

- **DM/DG File Migration Services**

Take the burden of file migration from your IT's shoulders. Our experts will align your requirements and business objectives to the migration plans while coordinating with your team to plan and safely execute the data migration to your storage platforms.

- **DM/DG/DE Health Check Services**

Our experts perform proactive checks of your Firmware and system health to ensure your machines are operating at peak and optimal efficiency to maximize up-time, avoid system failures, ensure the security of IT solutions and simplify maintenance.

- **Factory Integrated Services**

A suite of value-added offerings provided during the manufacturing phase of a server or storage system that reduces time to value. These services aim at improving your hardware deployment experience and enhance the quality of a standard configuration before it arrives at your facility.

## **Lenovo Support Services**

In addition to response time options for hardware parts, repairs, and labor, Lenovo offers a wide array of additional support services to ensure your business is positioned for success and longevity. Our goal is to reduce your capital outlays, mitigate your IT risks, and accelerate your time to productivity.

- **Premier Support for Data Centers**

Your direct line to the solution that promises the best, most comprehensive level of support to help you fully unlock the potential of your data center.

- **Premier Enhanced Storage Support (PESS)**

Gain all the benefits of Premier Support for Data Centers, adding dedicated storage specialists and resources to elevate your storage support experience to the next level.

- **Committed Service Repair (CSR)**

Our commitment to ensuring the fastest, most seamless resolution times for mission-critical systems that require immediate attention to ensure minimal downtime and risk for your business. This service is only available for machines under the Premier 4-Hour Response SLA.

- **Multivendor Support Services (MVS)**

Your single point of accountability for resolution support across vast range of leading Server, Storage, and Networking OEMs, allowing you to manage all your supported infrastructure devices seamlessly from a single source.

- **Keep Your Drive (KYD)**

Protect sensitive data and maintain compliance with corporate retention and disposal policies to ensure your data is always under your control, regardless of the number of drives that are installed in your Lenovo server.

- **Technical Account Manager (TAM)**

Your single point of contact to expedite service requests, provide status updates, and furnish reports to track incidents over time, ensuring smooth operations and optimized performance as your business grows.

- **Enterprise Software Support (ESS)**

Gain comprehensive, single-source, and global support for a wide range of server operating systems and Microsoft server applications.

For more information, consult the brochure [Lenovo Operational Support Services for Data Centers](#).

## Lenovo Managed Services

Achieve peak efficiency, high security, and minimal disruption with Lenovo's always-on Managed Services. Our real-time monitoring, 24x7 incident response, and problem resolution ensure your infrastructure operates seamlessly. With quarterly health checks for ongoing optimization and innovation, Lenovo's remote active monitoring boosts end-user experience and productivity by keeping your data center's hardware performing at its best.

Lenovo Managed Services provides continuous 24x7 remote monitoring (plus 24x7 call center availability) and proactive management of your data center using state-of-the-art tools, systems, and practices by a team of highly skilled and experienced Lenovo services professionals.

Quarterly reviews check error logs, verify firmware & OS device driver levels, and software as needed. We'll also maintain records of latest patches, critical updates, and firmware levels, to ensure you systems are providing business value through optimized performance.

## Lenovo Sustainability Services

- **Asset Recovery Services**

Lenovo Asset Recovery Services (ARS) provides a secure, seamless solution for managing end-of-life IT assets, ensuring data is safely sanitized while contributing to a more circular IT lifecycle. By maximizing the reuse or responsible recycling of devices, ARS helps businesses meet sustainability goals while recovering potential value from their retired equipment. For more information, see the [Asset Recovery Services offering page](#).

- **CO2 Offset Services**

Lenovo's CO2 Offset Services offer a simple and transparent way for businesses to take tangible action on their IT footprint. By integrating CO2 offsets directly into device purchases, customers can easily support verified climate projects and track their contributions, making meaningful progress toward their sustainability goals without added complexity.

- **Lenovo Certified Refurbished**

Lenovo Certified Refurbished offers a cost-effective way to support IT circularity without compromising on quality and performance. Each device undergoes rigorous testing and certification, ensuring reliable performance and extending its lifecycle. With Lenovo's trusted certification, you gain peace of mind while making a more sustainable IT choice.

## Lenovo TruScale

Lenovo TruScale XaaS is your set of flexible IT services that makes everything easier. Streamline IT procurement, simplify infrastructure and device management, and pay only for what you use – so your business is free to grow and go anywhere.

Lenovo TruScale is the unified solution that gives you simplified access to:

- The industry's broadest portfolio – from pocket to cloud – all delivered as a service
- A single-contract framework for full visibility and accountability
- The global scale to rapidly and securely build teams from anywhere
- Flexible fixed and metered pay-as-you-go models with minimal upfront cost
- The growth-driving combination of hardware, software, infrastructure, and solutions – all from one single provider with one point of accountability.

For information about Lenovo TruScale offerings that are available in your region, contact your local Lenovo sales representative or business partner.

## Regulatory compliance

The SR650 V4 conforms to the following standards:

- CE, UKCA Mark (EN55032 Class A, EN62368-1, EN55035, EN61000-3-11, EN61000-3-12, (EU) 2019/424, and EN IEC 63000 (RoHS))
- FCC - Verified to comply with Part 15 of the FCC Rules, Class A
- Canada ICES-003, issue 7, Class A
- CISPR 32, Class A, CISPR 35
- Korea KS C 9832 Class A, KS C 9835
- Japan VCCI, Class A
- Taiwan BSMI CNS15936, Class A; CNS15598-1; Section 5 of CNS15663
- Australia/New Zealand AS/NZS CISPR 32, Class A; AS/NZS 62368.1
- UL Green Guard, UL2819
- [Energy Star 4.0](#)
- EPEAT (NSF/ ANSI 426) Bronze
- Japanese Energy-Saving Act
- EU2019/424 Energy Related Product (ErP Lot9)
- TCO Certified
- China CCC certificate, GB17625.1; GB4943.1; GB/T9254
- China CECF certificate, CQC3135
- China CELP certificate, HJ 2507-2011

## External drive enclosures

The server supports attachment to external drive enclosures using a RAID controller with external ports or a SAS host bus adapter. Adapters supported by the server are listed in the [SAS adapters for external storage](#) section.

**Note:** Information provided in this section is for ordering reference purposes only. For the operating system and adapter support details, refer to the interoperability matrix for a particular storage enclosure that can be found on the Lenovo Data Center Support web site:

<http://datacentersupport.lenovo.com>

Table 106. External drive enclosures

Model	Description
4587HC1	Lenovo Storage D1212 Disk Expansion Enclosure (2U enclosure with 12x LFF drive bays)
4587HC2	Lenovo Storage D1224 Disk Expansion Enclosure (2U enclosure with 24x SFF drive bays)
6413HC1	Lenovo Storage D3284 High Density Expansion Enclosure (5U enclosure with 84x LFF drive bays)
7DAHCTO1WW	Lenovo ThinkSystem D4390 Direct Attached Storage (4U enclosure with 90x LFF drive bays)

For details about supported drives, adapters, and cables, see the following Lenovo Press Product Guides:

- [Lenovo Storage D1212 and D1224](http://lenovopress.lenovo.com/lp0512)  
<http://lenovopress.lenovo.com/lp0512>
- [Lenovo Storage D3284](http://lenovopress.lenovo.com/lp0513)  
<http://lenovopress.lenovo.com/lp0513>
- [Lenovo ThinkSystem D4390](https://lenovopress.lenovo.com/lp1681)  
<https://lenovopress.lenovo.com/lp1681>

## External storage systems

Lenovo offers the ThinkSystem DE Series, ThinkSystem DG Series and ThinkSystem DM Series external storage systems for high-performance storage. See the DE Series, DG Series and DM Series product guides for specific controller models, expansion enclosures and configuration options:

- ThinkSystem DE Series Storage  
<https://lenovopress.com/storage/thinksystem/de-series#rt=product-guide>
- ThinkSystem DM Series Storage  
<https://lenovopress.com/storage/thinksystem/dm-series#rt=product-guide>
- ThinkSystem DG Series Storage  
<https://lenovopress.com/storage/thinksystem/dg-series#rt=product-guide>

## External backup units

The following table lists the external backup options that are offered by Lenovo.

Table 107. External backup options

Part number	Description
External RDX USB drives	
4T27A10725	ThinkSystem RDX External USB 3.0 Dock
External SAS tape backup drives	
6160S7E	IBM TS2270 Tape Drive Model H7S
6160S8E	IBM TS2280 Tape Drive Model H8S
6160S9E	IBM TS2290 Tape Drive Model H9S
External SAS tape backup autoloaders	
6171S7R	IBM TS2900 Tape Autoloader w/LTO7 HH SAS
6171S8R	IBM TS2900 Tape Autoloader w/LTO8 HH SAS
6171S9R	IBM TS2900 Tape Autoloader w/LTO9 HH SAS
External tape backup libraries	
6741A1F	IBM TS4300 3U Tape Library-Base Unit
6741A3F	IBM TS4300 3U Tape Library-Expansion Unit
Full High 8 Gb Fibre Channel for TS4300	
01KP938	LTO 7 FH Fibre Channel Drive
01KP954	LTO 8 FH Fibre Channel Drive
02JH837	LTO 9 FH Fibre Channel Drive
Half High 8 Gb Fibre Channel for TS4300	
01KP936	LTO 7 HH Fibre Channel Drive
01KP952	LTO 8 HH Fibre Channel Drive
02JH835	LTO 9 HH Fibre Channel Drive
Half High 6 Gb SAS for TS4300	
01KP937	LTO 7 HH SAS Drive
01KP953	LTO 8 HH SAS Drive
02JH836	LTO 9 HH SAS Drive

For more information, see the list of Product Guides in the Backup units category:  
<https://lenovopress.com/servers/options/backup>

## Fibre Channel SAN switches

Lenovo offers the ThinkSystem DB Series of Fibre Channel SAN switches for high-performance storage expansion. See the DB Series product guides for models and configuration options:

- ThinkSystem DB Series SAN Switches:  
<https://lenovopress.com/storage/switches/rack#rt=product-guide>

## Uninterruptible power supply units

The following table lists the uninterruptible power supply (UPS) units that are offered by Lenovo.

Table 108. Uninterruptible power supply units

Part number	Description
Rack-mounted or tower UPS units - 100-125VAC	
7DD5A001WW	RT1.5kVA 2U Rack or Tower UPS-G2 (100-125VAC)
7DD5A003WW	RT3kVA 2U Rack or Tower UPS-G2 (100-125VAC)
Rack-mounted or tower UPS units - 200-240VAC	
7DD5A002WW	RT1.5kVA 2U Rack or Tower UPS-G2 (200-240VAC)
7DD5A005WW	RT3kVA 2U Rack or Tower UPS-G2 (200-240VAC)
7DD5A007WW	RT5kVA 3U Rack or Tower UPS-G2 (200-240VAC)
7DD5A008WW	RT6kVA 3U Rack or Tower UPS-G2 (200-240VAC)
7DD5A00AWW	RT11kVA 6U Rack or Tower UPS-G2 (200-240VAC)

† Only available in China and the Asia Pacific market.

For more information, see the list of Product Guides in the UPS category:

<https://lenovopress.com/servers/options/ups>

## Power distribution units

The following table lists the power distribution units (PDUs) that are offered by Lenovo.

Table 109. Power distribution units

Part number	Feature code	Description	ANZ	ASEAN	Brazil	EET	MEA	RUCIS	WE	HTK	INDIA	JAPAN	LA	NA	PRC
<b>0U Basic PDUs</b>															
4PU7A93176	C0QH	0U 36 C13 and 6 C19 Basic 32A 1 Phase PDU v2	Y	Y	Y	Y	Y	Y	Y	Y	Y	N	Y	Y	Y
4PU7A93169	C0DA	0U 36 C13 and 6 C19 Basic 32A 1 Phase PDU	Y	Y	Y	Y	Y	Y	Y	Y	Y	N	Y	Y	Y
4PU7A93177	C0QJ	0U 24 C13/C15 and 24 C13/C15/C19 Basic 32A 3 Phase WYE PDU v2	Y	Y	Y	Y	Y	Y	Y	Y	Y	Y	Y	Y	Y
4PU7A93170	C0D9	0U 24 C13/C15 and 24 C13/C15/C19 Basic 32A 3 Phase WYE PDU	Y	Y	Y	Y	Y	Y	Y	Y	Y	N	Y	Y	Y
<b>0U Switched and Monitored PDUs</b>															
4PU7A93181	C0QN	0U 21 C13/C15 and 21 C13/C15/C19 Switched and Monitored 48A 3 Phase Delta PDU v2 (60A derated)	N	Y	N	N	N	N	N	Y	N	Y	N	Y	N
4PU7A93174	C0D5	0U 21 C13/C15 and 21 C13/C15/C19 Switched and Monitored 48A 3 Phase Delta PDU (60A derated)	N	Y	N	N	N	N	N	Y	N	N	N	Y	N
4PU7A93178	C0QK	0U 20 C13 and 4 C19 Switched and Monitored 32A 1 Phase PDU v2	Y	Y	Y	Y	Y	Y	Y	Y	Y	N	Y	Y	Y
4PU7A93171	C0D8	0U 20 C13 and 4 C19 Switched and Monitored 32A 1 Phase PDU	Y	Y	Y	Y	Y	Y	Y	Y	Y	N	Y	Y	Y
4PU7A93182	C0QP	0U 18 C13/C15 and 18 C13/C15/C19 Switched and Monitored 63A 3 Phase WYE PDU v2	Y	Y	Y	Y	Y	Y	Y	Y	Y	Y	Y	Y	Y
4PU7A93175	C0CS	0U 18 C13/C15 and 18 C13/C15/C19 Switched and Monitored 63A 3 Phase WYE PDU	Y	Y	Y	Y	Y	Y	Y	Y	Y	N	Y	Y	Y
4PU7A93180	C0QM	0U 18 C13/C15 and 18 C13/C15/C19 Switched and Monitored 32A 3 Phase WYE PDU v2	Y	Y	Y	Y	Y	Y	Y	Y	Y	Y	Y	Y	Y
4PU7A93173	C0D6	0U 18 C13/C15 and 18 C13/C15/C19 Switched and Monitored 32A 3 Phase WYE PDU	Y	Y	Y	Y	Y	Y	Y	Y	Y	N	Y	Y	Y
4PU7A93179	C0QL	0U 16 C13/C15 and 16 C13/C15/C19 Switched and Monitored 24A 1 Phase PDU v2 (30A derated)	N	Y	N	N	N	N	N	Y	N	Y	N	Y	N
4PU7A93172	C0D7	0U 16 C13/C15 and 16 C13/C15/C19 Switched and Monitored 24A 1 Phase PDU(30A derated)	N	Y	N	N	N	N	N	Y	N	N	N	Y	N
<b>1U Switched and Monitored PDUs</b>															
4PU7A90808	C0D4	1U 18 C19/C13 Switched and monitored 48A 3P WYE PDU V2 ETL	N	N	N	N	N	N	N	Y	N	Y	Y	Y	N
4PU7A81117	BNDV	1U 18 C19/C13 switched and monitored 48A 3P WYE PDU - ETL	N	N	N	N	N	N	N	N	N	N	N	Y	N
4PU7A90809	C0DE	1U 18 C19/C13 Switched and monitored 48A 3P WYE PDU V2 CE	Y	Y	Y	Y	Y	Y	Y	Y	Y	Y	Y	N	Y
4PU7A81118	BNDW	1U 18 C19/C13 switched and monitored 48A 3P WYE PDU – CE	Y	Y	Y	Y	Y	Y	Y	Y	Y	Y	Y	N	Y
4PU7A90810	C0DD	1U 18 C19/C13 Switched and monitored 80A 3P Delta PDU V2	N	N	N	N	N	N	N	Y	N	Y	Y	Y	N
4PU7A77467	BLC4	1U 18 C19/C13 Switched and Monitored 80A 3P Delta PDU	N	N	N	N	N	N	N	N	N	Y	N	Y	N

Part number	Feature code	Description	ANZ	ASEAN	Brazil	EET	MEA	RUCIS	WE	HTK	INDIA	JAPAN	LA	NA	PRC
4PU7A90811	C0DC	1U 12 C19/C13 Switched and monitored 32A 3P WYE PDU V2	Y	Y	Y	Y	Y	Y	Y	Y	Y	Y	Y	Y	Y
4PU7A90812	C0DB	1U 12 C19/C13 Switched and monitored 60A 3P Delta PDU V2	N	N	N	N	N	N	N	Y	N	Y	Y	Y	N
4PU7A77469	BLC6	1U 12 C19/C13 switched and monitored 60A 3P Delta PDU	N	N	N	N	N	N	N	N	N	N	N	Y	N
71763NU	6051	Ultra Density Enterprise C19/C13 PDU 60A/208V/3PH	N	N	Y	N	N	N	N	N	N	Y	Y	Y	N
71762NX	6091	Ultra Density Enterprise C19/C13 PDU Module	Y	Y	Y	Y	Y	Y	Y	Y	Y	Y	Y	Y	Y
<b>Line cords for 1U PDUs that ship without a line cord</b>															
40K9611	6504	DPI 32a Cord (IEC 309 3P+N+G)	Y	Y	Y	Y	Y	Y	Y	Y	Y	Y	Y	Y	Y
40K9612	6502	DPI 32a Cord (IEC 309 P+N+G)	Y	Y	Y	Y	Y	Y	Y	Y	Y	Y	Y	Y	Y
40K9613	6503	DPI 63a Cord (IEC 309 P+N+G)	Y	Y	Y	Y	Y	Y	Y	Y	Y	Y	Y	Y	Y
40K9614	6500	DPI 30a Cord (NEMA L6-30P)	Y	Y	Y	Y	Y	Y	Y	Y	Y	Y	Y	Y	Y
40K9615	6501	DPI 60a Cord (IEC 309 2P+G)	N	N	Y	N	N	N	Y	N	N	Y	Y	Y	N

For more information, see the Lenovo Press documents in the PDU category:  
<https://lenovopress.com/servers/options/pdu>

## Rack cabinets

The following table lists the supported rack cabinets.

Table 110. Rack cabinets

Model	Description
93072RX	25U Standard Rack (1000mm)
7D6DA007WW	ThinkSystem 42U Onyx Primary Heavy Duty Rack Cabinet (1200mm)
7D6DA008WW	ThinkSystem 42U Pearl Primary Heavy Duty Rack Cabinet (1200mm)
7D6EA009WW	ThinkSystem 48U Onyx Primary Heavy Duty Rack Cabinet (1200mm)
7D6EA00AWW	ThinkSystem 48U Pearl Primary Heavy Duty Rack Cabinet (1200mm)
1410O42	Lenovo EveryScale 42U Onyx Heavy Duty Rack Cabinet
1410P42	Lenovo EveryScale 42U Pearl Heavy Duty Rack Cabinet
1410O48	Lenovo EveryScale 48U Onyx Heavy Duty Rack Cabinet
1410P48	Lenovo EveryScale 48U Pearl Heavy Duty Rack Cabinet
93604PX	42U 1200mm Deep Dynamic Rack
93614PX	42U 1200mm Deep Static Rack
93634PX	42U 1100mm Dynamic Rack
93634EX	42U 1100mm Dynamic Expansion Rack
93074RX	42U Standard Rack (1000mm)

For specifications about these racks, see the Lenovo Rack Cabinet Reference, available from:  
<https://lenovopress.com/lp1287-lenovo-rack-cabinet-reference>

For more information, see the list of Product Guides in the Rack cabinets category:  
<https://lenovopress.com/servers/options/racks>

## KVM console options

The following table lists the supported KVM consoles.

Table 111. KVM console

Part number	Description
4XF7A84188	ThinkSystem 18.5" LCD console (with US English keyboard)

The following table lists the available KVM switches and the options that are supported with them.

Table 113. KVM switches and options

Part number	Description
KVM Console switches	
1754D1X	Global 2x2x16 Console Manager (GCM16)
1754A2X	Local 2x16 Console Manager (LCM16)
1754A1X	Local 1x8 Console Manager (LCM8)
Cables for GCM and LCM Console switches	
46M5383	Virtual Media Conversion Option Gen2 (VCO2)
46M5382	Serial Conversion Option (SCO)

For more information, see the list of Product Guides in the KVM Switches and Consoles category:  
<http://lenovopress.com/servers/options/kvm>

## Lenovo Financial Services

Why wait to obtain the technology you need now? No payments for 90 days and predictable, low monthly payments make it easy to budget for your Lenovo solution.

- **Flexible**

Our in-depth knowledge of the products, services and various market segments allows us to offer greater flexibility in structures, documentation and end of lease options.

- **100% Solution Financing**

Financing your entire solution including hardware, software, and services, ensures more predictability in your project planning with fixed, manageable payments and low monthly payments.

- **Device as a Service (DaaS)**

Leverage latest technology to advance your business. Customized solutions aligned to your needs. Flexibility to add equipment to support growth. Protect your technology with Lenovo's Premier Support service.

- **24/7 Asset management**

Manage your financed solutions with electronic access to your lease documents, payment histories, invoices and asset information.

- **Fair Market Value (FMV) and \$1 Purchase Option Leases**

Maximize your purchasing power with our lowest cost option. An FMV lease offers lower monthly payments than loans or lease-to-own financing. Think of an FMV lease as a rental. You have the flexibility at the end of the lease term to return the equipment, continue leasing it, or purchase it for the fair market value. In a \$1 Out Purchase Option lease, you own the equipment. It is a good option when you are confident you will use the equipment for an extended period beyond the finance term. Both lease types have merits depending on your needs. We can help you determine which option will best meet your technological and budgetary goals.

Ask your Lenovo Financial Services representative about this promotion and how to submit a credit application. For the majority of credit applicants, we have enough information to deliver an instant decision and send a notification within minutes.

## Seller training courses

The following sales training courses are offered for employees and partners (login required). Courses are listed in date order.

1. **Partner Technical Webinar - ISG Portfolio Update**

2024-04-15 | 60 minutes | Employees and Partners

In this 60-minute replay, Mark Bica, NA ISG Server Product Manager reviewed the Lenovo ISG portfolio. He covered new editions such as the SR680a \ SR685a, dense servers, and options that are strategic for any workload.

Tags: ThinkSystem

Published: 2024-04-15

Length: 60 minutes

**Start the training:**

Employee link: [Grow@Lenovo](mailto:Grow@Lenovo)

Partner link: [Lenovo Partner Learning](#)

Course code: 041224

## 2. **VTT Cloud Architecture: NVIDIA Using Cloud for GPUs and AI**

2024-05-22 | 60 minutes | Employees Only

Join JD Dupont, NVIDIA Head of Americas Sales, Lenovo partnership and Veer Mehta, NVIDIA Solution Architect on an interactive discussion about cloud to edge, designing cloud Solutions with NVIDIA GPUs and minimizing private/hybrid cloud OPEX with GPUs. Discover how you can use what is done at big public cloud providers for your customers. We will also walk through use cases and see a demo you can use to help your customers.

Tags: Artificial Intelligence (AI), Cloud, Nvidia, Software Defined Infrastructure (SDI), Technical Sales

Published: 2024-05-22

Length: 60 minutes

### **Start the training:**

Employee link: [Grow@Lenovo](#)

Course code: DVCLD212

## 3. **Lenovo Data Center Product Portfolio**

2024-05-29 | 20 minutes | Employees and Partners

This course introduces the Lenovo data center portfolio, and covers servers, storage, storage networking, and software-defined infrastructure products. After completing this course about Lenovo data center products, you will be able to identify product types within each data center family, describe Lenovo innovations that this product family or category uses, and recognize when a specific product should be selected.

Tags: Advanced DataCenter, DataCenter Products, ThinkAgile, ThinkEdge, ThinkSystem

Published: 2024-05-29

Length: 20 minutes

### **Start the training:**

Employee link: [Grow@Lenovo](#)

Partner link: [Lenovo Partner Learning](#)

Course code: SXXW1110r7

## 4. **SAP Webinar for Lenovo Sellers: Lenovo Portfolio Update for SAP Landscapes**

2024-06-04 | 60 minutes | Employees Only

Join Mark Kelly, Advisory IT Architect with the Lenovo Global SAP Center of Competence as he discusses:

- Challenges in the SAP environment
- Lenovo On-premise Solutions for SAP
- Lenovo support resources for SAP solutions

Tags: SAP, ThinkAgile, ThinkEdge, ThinkSystem

Published: 2024-06-04

Length: 60 minutes

### **Start the training:**

Employee link: [Grow@Lenovo](#)

Course code: DSAPF101

5. **Partner Technical Webinar - OneIQ**

2024-07-15 | 60 minutes | Employees and Partners

In this 60-minute replay, Peter Grant, Field CTO for OneIQ, reviewed and demo'd the capabilities of OneIQ including collecting data and analyzing. Additionally, Peter and the team discussed how specific partners (those with NA Channel SA coverage) will get direct access to OneIQ and other partners can get access to OneIQ via Distribution or the NA LETS team.

Tags: Technical Sales

Published: 2024-07-15

Length: 60 minutes

**Start the training:**

Employee link: [Grow@Lenovo](#)

Partner link: [Lenovo Partner Learning](#)

Course code: 071224

6. **Virtual Facilitated Session - ThinkSystem Rack and Tower Primer for ISO Client Managers**

2024-10-31 | 90 minutes | Employees Only

In this Virtual Instructor-Led Training Session, ISO Client Managers will be able to build on the knowledge gained in Module 1 (eLearning) of the ThinkSystem Rack and Tower Server Primer for ISO Client Managers curriculum.

IMPORTANT! Module 1 (eLearning) must be completed to be eligible to participate in this session. Please note that places are subject to availability. If you are selected, you will receive the invite to this session via email.

Tags: Sales, Server, ThinkSystem

Published: 2024-10-31

Length: 90 minutes

**Start the training:**

Employee link: [Grow@Lenovo](#)

Course code: DSRT0102

7. **Partner Technical Webinar - LenovoPress updates and LPH Demo**

2024-11-13 | 60 minutes | Employees and Partners

In this 60-minute replay, we had 3 topics. First, David Watts, Lenovo Sr Manager LenovoPress, gave an update on LenovoPress and improvements to finding Seller Training Courses (both partner and Lenovo). Next, Ryan Tuttle, Lenovo LETS Solution Architect, gave a demo of Lenovo Partner Hub (LPH) including how to find replays of Partner Webinars in LPL. Finally, Joe Murphy, Lenovo Sr Manager of LETS NA, gave a quick update on the new Stackable Warranty Options in DCSC.

Tags: Technical Sales

Published: 2024-11-13

Length: 60 minutes

**Start the training:**

Employee link: [Grow@Lenovo](#)

Partner link: [Lenovo Partner Learning](#)

Course code: 110824

## 8. **Partner Technical Webinar - Server Update with Mark Bica**

2024-11-26 | 60 minutes | Employees and Partners

In this 60-minute replay, Mark Bica, Lenovo Product Manager gave an update on the server portfolio. Mark presented on the new V4 Intel servers with Xeon 6 CPUs. He reviewed where the new AMD 5th Gen EPYC CPUs will be used in our servers. He followed with a review of the GPU dense servers including SR680, SR680a, SR575 and SR780a. Mark concluded with a review of the SC777 and SC750 that were introduced at TechWorld.

Tags: Server

Published: 2024-11-26

Length: 60 minutes

### **Start the training:**

Employee link: [Grow@Lenovo](#)

Partner link: [Lenovo Partner Learning](#)

Course code: 112224

## 9. **ThinkSystem Rack and Tower Introduction for ISO Client Managers**

2024-12-10 | 20 minutes | Employees Only

In this course, you will learn about Lenovo's Data Center Portfolio, its ThinkSystem Family and the key features of the Rack and Tower servers. It will equip you with foundational knowledge which you can then expand upon by participating in the facilitated session of the curriculum.

Course Objectives:

- By the end of this course, you should be able to:
- Identify Lenovo's main data center brands.
- Describe the key components of the ThinkSystem Family servers.
- Differentiate between the Rack and Tower servers of the ThinkSystem Family.
- Understand the value Rack and Tower servers can provide to customers.

Tags: Server, ThinkSystem

Published: 2024-12-10

Length: 20 minutes

### **Start the training:**

Employee link: [Grow@Lenovo](#)

Course code: DSRT0101r2

## 10. **Q4 Solutions Launch ThinkSystem SR630 V4, SR650 V4, SR650a V4 Update Quick Hit**

2025-02-12 | 5 minutes | Employees Only

This Quick Hit covers 3 new Lenovo servers – the ThinkSystem SR630 V4, SR650 V4, and SR650a V4 - designed to drive today's workloads and elevate data centers of any size to AI-enabled powerhouses. With designed-in and proven reliability, ThinkSystem V4 servers with Intel® Xeon 6 processors deliver a secure, AI-ready, scalable data center building block. Your customers will enjoy efficient, high-performing AI and other compute-intensive app execution with any one of these servers.

Tags: Cloud, Server, Storage, ThinkSystem, XClarity

Published: 2025-02-12

Length: 5 minutes

### **Start the training:**

Employee link: [Grow@Lenovo](#)

Course code: SXXW1204r14a

11. **Family Portfolio: Storage Controller Options**  
2025-03-03 | 25 minutes | Employees and Partners

This course covers the storage controller options available for use in Lenovo servers. The classes of storage controller are discussed, along with a discussion of where they are used, and which to choose.

After completing this course, you will be able to:

- Describe the classes of storage controllers
- Discuss where each controller class is used
- Describe the available options in each controller class

Tags: Sales, Storage

Published: 2025-03-03

Length: 25 minutes

**Start the training:**

Employee link: [Grow@Lenovo](mailto:Grow@Lenovo)

Partner link: [Lenovo Partner Learning](#)

Course code: SXXW1111r2

12. **Lenovo VTT Cloud Architecture: Intel Xeon 6: Performance and Efficiency**  
2025-03-05 | 60 minutes | Employees Only

Intel Xeon 6 processors introduce a robust computing platform that excels at both performance and efficiency, crucial for meeting the evolving demands of modern data centers. Addressing the broadest array of uses and workloads, from compute-intensive HPC & AI to traditional enterprise apps to scalable cloud-native applications, Intel Xeon 6 provides versatility for diverse operational and workload requirements.

Please join our guest speakers, Bhanu Jaiswal, Intel Product Line Manager and Rakib Sarwar, Intel Technical Sales Manager as they discuss Intel's latest family of processors.

Tags: Artificial Intelligence (AI), Server, Technical Sales, ThinkAgile, ThinkSystem

Published: 2025-03-05

Length: 60 minutes

**Start the training:**

Employee link: [Grow@Lenovo](mailto:Grow@Lenovo)

Course code: DVCLD220

13. **Partner Technical Webinar - Intel Product Update and How to Co-solution**  
2025-03-13 | 60 minutes | Employees and Partners

In this 60-minute replay, Mark Bica, NA ISG Server Product Manager, shares the latest updates to the server portfolio. Following Mark's presentation, Brendan McDermott, Sr. Sales Engineer, and Wayne Pecht, Channel Technical Strategist, demonstrated how to use Mark's product updates to co-solution with Lenovo.

Tags: DataCenter Products

Published: 2025-03-13

Length: 60 minutes

**Start the training:**

Employee link: [Grow@Lenovo](mailto:Grow@Lenovo)

Partner link: [Lenovo Partner Learning](#)

Course code: 030725

14. **Lenovo Cloud Architecture VTT: Supercharge Your Enterprise AI with NVIDIA AI Enterprise on Lenovo Hybrid AI Platform**

2025-04-17 | 75 minutes | Employees Only

Join us for an in-depth webinar with Justin King, Principal Product Marketing Manager for Enterprise AI exploring the power of NVIDIA AI Enterprise, delivering Generative and Agentic AI outcomes deployed with Lenovo Hybrid AI platform environments.

In today's data-driven landscape, AI is evolving at high speed, with new techniques delivering more accurate responses. Enterprises are seeking not just an understanding but also how they can achieve AI-driven business outcomes.

With this, the demand for secure, scalable, and high-performing AI operations-and the skills to deliver them-is top of mind for many. Learn how NVIDIA AI Enterprise, a comprehensive software suite optimized for NVIDIA GPUs, provides the tools and frameworks, including NVIDIA NIM, NeMo, and Blueprints, to accelerate AI development and deployment while reducing risk-all within the control and security of your Lenovo customer's hybrid AI environment.

Tags: Artificial Intelligence (AI), Cloud, Data Management, Nvidia, Technical Sales

Published: 2025-04-17

Length: 75 minutes

**Start the training:**

Employee link: [Grow@Lenovo](mailto:Grow@Lenovo)

Course code: DVCLD221

15. **Partner Technical Webinar - DCSC Improvements - MAY0225**

2025-05-05 | 60 minutes | Partners Only

In this 60-minute replay, new improvements to DCSC were reviewed. Joe Allen, Lenovo NA LETS, presented the new PCI wizard and discussed RAID adapters. Ryan Tuttle, Lenovo NA LETS presented Spreadsheet import, Autocorrect and Expanded selections on by default. Joe Murphy, Lenovo NA LETS closed out with review of Error Message improvements and location of ThinkAgile MX and VX in the DCSC menus.

Tags: Technical Sales

Published: 2025-05-05

Length: 60 minutes

**Start the training:**

Partner link: [Lenovo Partner Learning](#)

Course code: MAY0225

## Related publications and links

For more information, see these resources:

- Lenovo SR650 V4 product page:  
<https://www.lenovo.com/us/en/p/servers-storage/servers/racks/thinksystem-sr650-v4/LEN21TS0042>
- ThinkSystem SR650 V4 datasheet  
<https://lenovopress.lenovo.com/datasheet/ds0194-lenovo-thinksystem-sr650-v4>
- ThinkSystem SR650 V4 drivers and support  
<http://datacentersupport.lenovo.com/products/servers/thinksystem/sr650v4/7dgd/downloads>
- Lenovo ThinkSystem SR650 V4 product publications:  
<https://pubs.lenovo.com/sr650-v4/>
  - User Guide, which includes:
    - System Configuration Guide
    - Hardware Maintenance Guide
  - Rack Installation Guides
  - Messages and Codes Reference
  - UEFI Manual for ThinkSystem Servers
- User Guides for options:  
<https://serveroption.lenovo.com>
- ServerProven hardware compatibility:  
<http://serverproven.lenovo.com>

## Related product families

Product families related to this document are the following:

- [2-Socket Rack Servers](#)
- [ThinkSystem SR650 V4 Server](#)

## Notices

Lenovo may not offer the products, services, or features discussed in this document in all countries. Consult your local Lenovo representative for information on the products and services currently available in your area. Any reference to a Lenovo product, program, or service is not intended to state or imply that only that Lenovo product, program, or service may be used. Any functionally equivalent product, program, or service that does not infringe any Lenovo intellectual property right may be used instead. However, it is the user's responsibility to evaluate and verify the operation of any other product, program, or service. Lenovo may have patents or pending patent applications covering subject matter described in this document. The furnishing of this document does not give you any license to these patents. You can send license inquiries, in writing, to:

Lenovo (United States), Inc.  
8001 Development Drive  
Morrisville, NC 27560  
U.S.A.  
Attention: Lenovo Director of Licensing

LENOVO PROVIDES THIS PUBLICATION "AS IS" WITHOUT WARRANTY OF ANY KIND, EITHER EXPRESS OR IMPLIED, INCLUDING, BUT NOT LIMITED TO, THE IMPLIED WARRANTIES OF NON-INFRINGEMENT, MERCHANTABILITY OR FITNESS FOR A PARTICULAR PURPOSE. Some jurisdictions do not allow disclaimer of express or implied warranties in certain transactions, therefore, this statement may not apply to you.

This information could include technical inaccuracies or typographical errors. Changes are periodically made to the information herein; these changes will be incorporated in new editions of the publication. Lenovo may make improvements and/or changes in the product(s) and/or the program(s) described in this publication at any time without notice.

The products described in this document are not intended for use in implantation or other life support applications where malfunction may result in injury or death to persons. The information contained in this document does not affect or change Lenovo product specifications or warranties. Nothing in this document shall operate as an express or implied license or indemnity under the intellectual property rights of Lenovo or third parties. All information contained in this document was obtained in specific environments and is presented as an illustration. The result obtained in other operating environments may vary. Lenovo may use or distribute any of the information you supply in any way it believes appropriate without incurring any obligation to you.

Any references in this publication to non-Lenovo Web sites are provided for convenience only and do not in any manner serve as an endorsement of those Web sites. The materials at those Web sites are not part of the materials for this Lenovo product, and use of those Web sites is at your own risk. Any performance data contained herein was determined in a controlled environment. Therefore, the result obtained in other operating environments may vary significantly. Some measurements may have been made on development-level systems and there is no guarantee that these measurements will be the same on generally available systems. Furthermore, some measurements may have been estimated through extrapolation. Actual results may vary. Users of this document should verify the applicable data for their specific environment.

**© Copyright Lenovo 2025. All rights reserved.**

This document, LP2127, was created or updated on April 29, 2025.

Send us your comments in one of the following ways:

- Use the online Contact us review form found at:  
<https://lenovopress.lenovo.com/LP2127>
- Send your comments in an e-mail to:  
[comments@lenovopress.com](mailto:comments@lenovopress.com)

This document is available online at <https://lenovopress.lenovo.com/LP2127>.

## Trademarks

Lenovo and the Lenovo logo are trademarks or registered trademarks of Lenovo in the United States, other countries, or both. A current list of Lenovo trademarks is available on the Web at <https://www.lenovo.com/us/en/legal/copytrade/>.

The following terms are trademarks of Lenovo in the United States, other countries, or both:

Lenovo®  
AnyBay®  
Neptune®  
ServerProven®  
System x®  
ThinkAgile®  
ThinkShield®  
ThinkSystem®  
XClarity®

The following terms are trademarks of other companies:

AMD is a trademark of Advanced Micro Devices, Inc.

Intel® and Xeon® are trademarks of Intel Corporation or its subsidiaries.

Linux® is the trademark of Linus Torvalds in the U.S. and other countries.

Microsoft®, ActiveX®, Excel®, Hyper-V®, PowerShell, SharePoint®, Windows PowerShell®, Windows Server®, and Windows® are trademarks of Microsoft Corporation in the United States, other countries, or both.

IBM®, IBM Security®, Power®, Resilient®, and Think® are trademarks of IBM in the United States, other countries, or both.

Other company, product, or service names may be trademarks or service marks of others.